

# **FOWLER**

**SCAFFOLD HOISTS FORMWORK**

USER INFORMATION

## INDEX

SUPER DESTIL WALL     **1**  
FORM & TABLE FORM  
SYSTEM

DESTIL MINI HAND     **71**  
SET WALL FORM  
SYSTEM

UNIDECK ALUMINIUM   **117**  
PANEL SLAB  
FORMWORK SYSTEM

ALU PROPS /             **125**  
ALU TOWERS

STEEL PROPS /         **141**  
EURO PROPS



**FOWLER**

SCAFFOLD HOISTS FORMWORK

FRAMED  
FORMWORK  
SUPER DESTIL

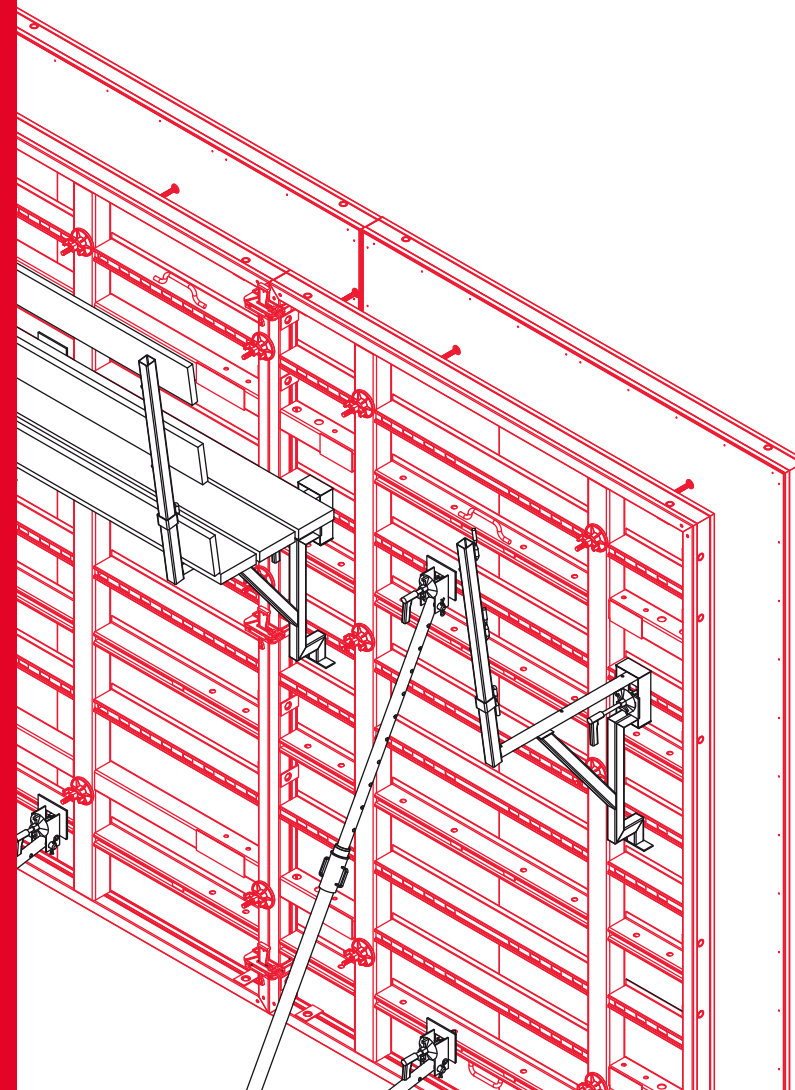

USER INFORMATION

## SAFETY WARNINGS

- The respect of these instructions does not exempt from compliance with all safety regulations in force in the country where you use the system.
- These instructions are intended for users of Fowler products and systems. Operators must be aware of the contents of this manual; in case they have difficulties in reading the same, contact Fowler Formwork Manager.
- The User's Manual instructions must always be available at the workplace for all operators.
- This manual, even if used in order to draw up a Method Statement, will not substitute it, and the Method Statement will remain an important and unavoidable site document, responsibility of the client.

- **Information and illustrations contained herein are relative to only the system in question, and therefore not exhaustive about the overall security; always refer to the applicable health and safety regulations in the area of use of the equipment.**
- **In relation to flow, configuration, installation, use and dismantling of equipment Strictly obey all instructions contained herein; failure to comply with them may result in serious injury to people, as well as extensive property damage.**
- Take every precaution consequently due to the climatic conditions of the site (i.e. in case of rain and/or ice to provide anti-slip measures etc.)
- Periodically verify, especially after severe weather conditions, any connection, wedge or any other connecting element, in order to avoid any possible system instability and consequent accidents.

# SUMMARY

FEATURES	5
FRAME DETAILS	6
ELEMENT CONNECTIONS	10
CLOSURE SOLUTIONS / INFILL	16
ASSEMBLING INSTRUCTIONS	18
PANEL STRUTS / PUSH PULL PROPS	18
CORNERS	22
STOP ENDS	28
WALLS OFFSET SOLUTIONS	31
COLUMNS	34
SHAFTS	36
SHIFTING & STORAGE	37
LIFTING INSTRUCTIONS	39
SUPER DESTIL ELEMENTS	40
SUPER DESTIL ACCESSORIES	44
ITEMS LIST	55





## FEATURES

Destil wall framed formwork is a new system for efficient concrete construction technology and is now available.

DESTIL offers increased efficiency and reduces costs through the following:

**PANEL HEIGHTS:** Formwork with a wide range of modularity available in heights of 3.6m, 3.3m, 2.7m, 1.35m and 1.2m.

**PANEL WIDTHS:** 2.4m, 2.1m, 1.8m, 1.35m, 1.2m, 1.0m, 0.9m, 0.75m, 0.6m, 0.45m and 0.3m.

**STEEL:** highly resisting steel, type S315MC.

**Frame depth:** 123 mm

**Thickness:** 2.50 mm

**Finishing technique:** hot Zinc-coat

**MAX CONCRETE PRESSURE:** 80 kN/m<sup>2</sup> USING D 20 Tie-rods

**HIGH-QUALITY PLYWOOD:** 18 mm birch quality-plywood or a plastic-coated plywood that lives 3 times longer or full composite plastic board.

**HIGH COMPATIBILITY:** The formwork is perfectly compatible with other formwork systems currently in the market.

**NEW CONCRETE FINISHES:** Thanks to an innovative steel profile, we have improved visible concrete surfaces. Destil Formwork are for Works of Art.

**LONG LIFE:** Frames and profiles are hot dipped galvanized both inside and outside.

**LOW DENSITY OF TIE RODS:** You need only 2 tie rods for concreting heights up to 3.0m panel, decreasing the assembly times.

**LARGE-AREA CRANE OPERATION:** Versatile, quickly assembled and movable in large units. Destil is used on both small and large construction sites.

**FAST CONNECTION OF PANEL:** Particular geometry of steel profile allows the connection of different steel frame modules in any position by Quick-acting clamps and Multi- function clamps.

**CORNERS AND CIRCULAR WALLS:** All corners, articulated corners and panels for circular walls or columns are available.

**TECHNICAL ASSISTANCE:** We ensure technical assistance pre-and post-sale.

**ACCESSORIES:** Full range and interchangeability of all accessories.

**SPEED:** Fast system for Walls, Columns and Slabs. Rapid planting, removing and moving on-site of formwork. The construction time is reduced by 25% compared to conventional methods.

**REUTILISATION:** High number of possible reutilisation. This steel frame system allows the construction of the following:

- Vertical formwork
- Horizontal formwork
- Formwork supported by shoring system
- Climbing formwork suitable for towers and bridge piers
- Dam formwork
- Formwork suitable for construction of elevator shafts
- Single-faced concreting formwork
- Tunnel formwork.

## DESTIL FRAMED FORMWORK

1 Highly resistant steel frame, 123 mm high, with perimetral concavity adapted for insertion of connection clamps in any position.

2 Perimetric holes adapted and suitable for higher planting versatility (Example: Formwork modules can be joined with bolts or with Universal fixing bolt).

3 Profile S, the optimal and versatile solution to hook all the accessories of Destil system, shortening formworking and dismantling time.

4 Conic holes suitable for easier mounting operations of tie rods. Low density of tie rods per square metre, just two on the 3-metre high module which permits reduced labor costs (up to 30% in comparison to 3 anchorage points).

5 Every profile has numerous holes at constant distances for easier and universal insertion of each accessory.

6 Birch multilayer panel, 18 mm thick, with superficial phenolic treatment, easy to clean, and sealed perimetrically with silicon seal process. Also available, plastic-coated plywood that lives three times longer and full composite sheeting. A wide range modularity of framed formwork together with availability of different size panels, including Super Destil extra large dimensions, permits constructions of any kind, size, and measure. High compatibility with other formwork systems currently on the market.

### DETAIL: FRAME

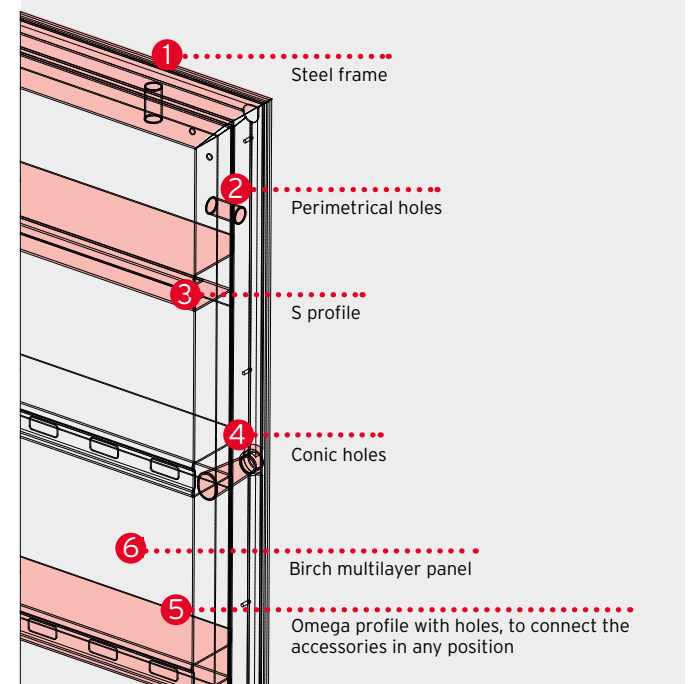



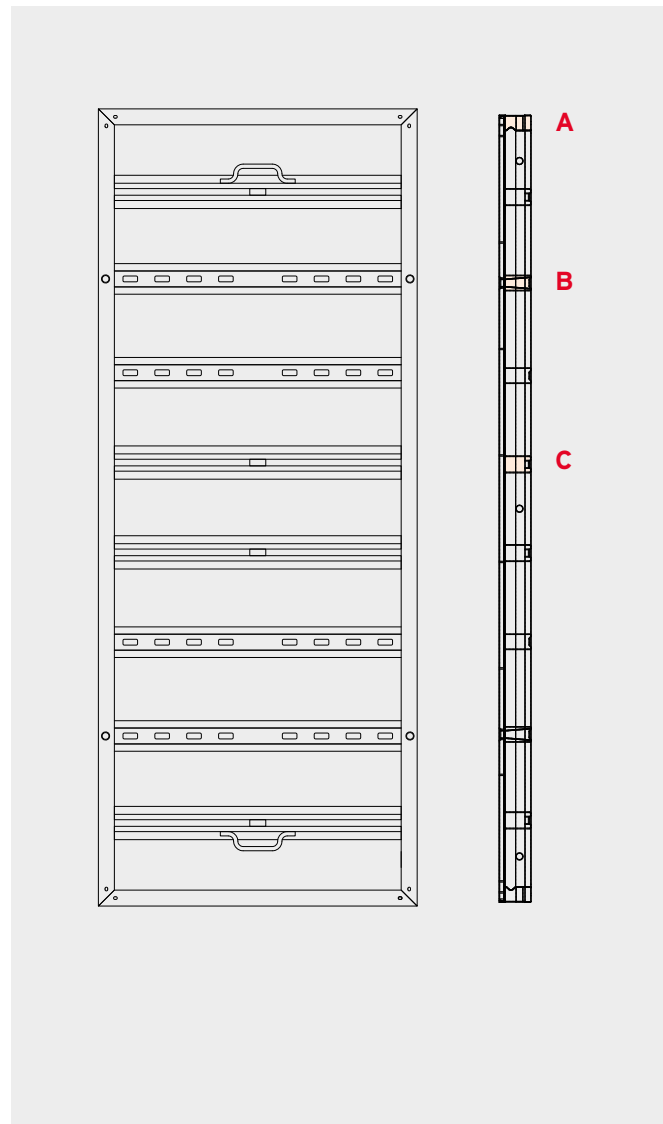

**A BORDER FRAME PROFILE**



**B OMEGA PROFILE**

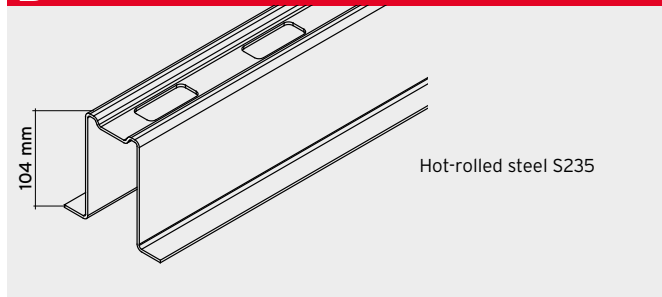

**C "S" PROFILE**

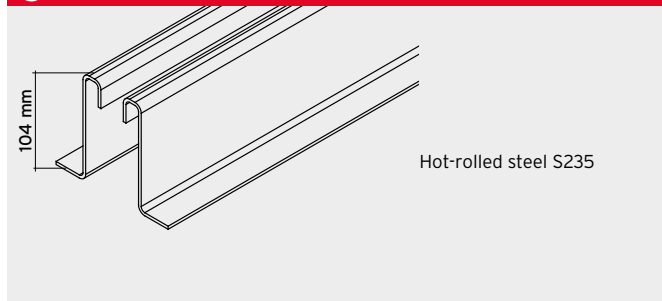

**DESTIL FRAME FORMWORK PANELS**

Destil Framed Panels  
Logical modular system in steps of 150 mm. The heights and the widths of the frame Destil elements form a modular system logical and simple to use that makes the formwork particularly flexible and cost effective.

- easy planning and forming
- adjustment of the height and width in steps of 150 mm
- few compensations required
- clear positioning of junctions.

Only two anchors in height till a height of 3000 mm, with elements of 3300 mm and 3600 mm, only 3 anchors are required in height. Largest distance between anchors in width: 1350 mm

- 10 panel widths,
- 5 panel heights
- 3 Super Destil panels with large dimensions

With this wide range you can form any geometry.

**PANEL WIDTH**

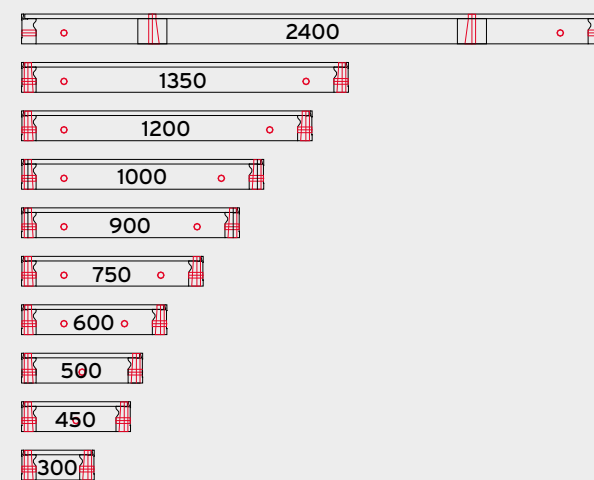

**UNIVERSAL PANEL WIDTH**

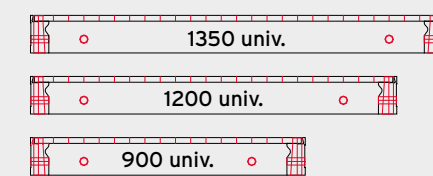

**SUPER DESTIL WIDTH**

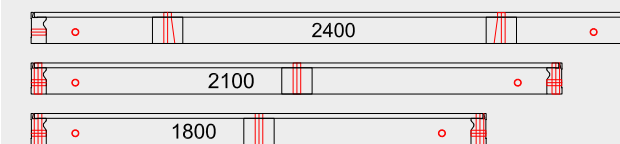

**PANEL HEIGHT**

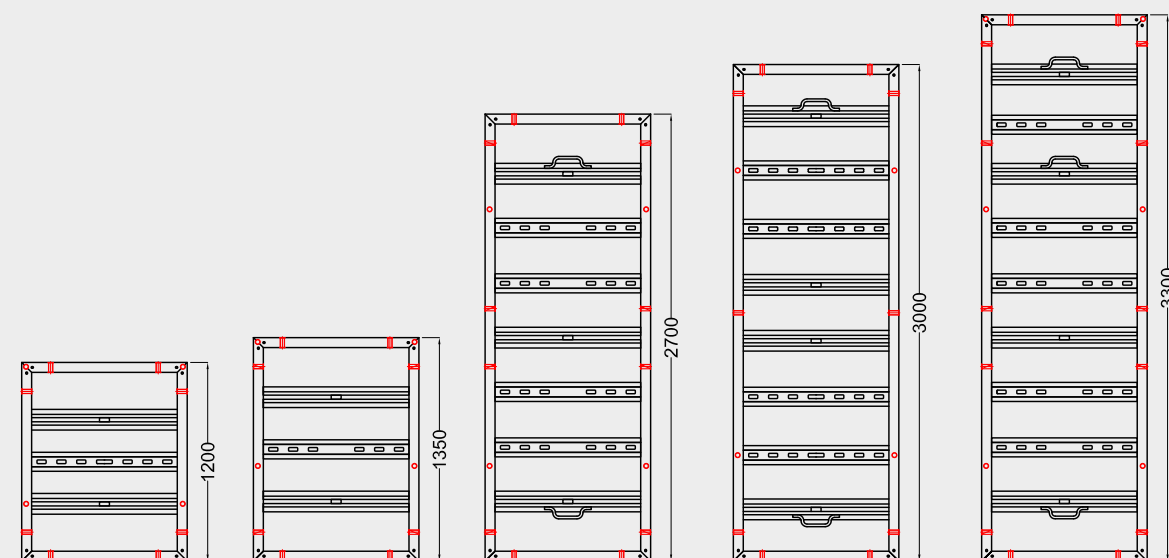

**LARGE PANELS**

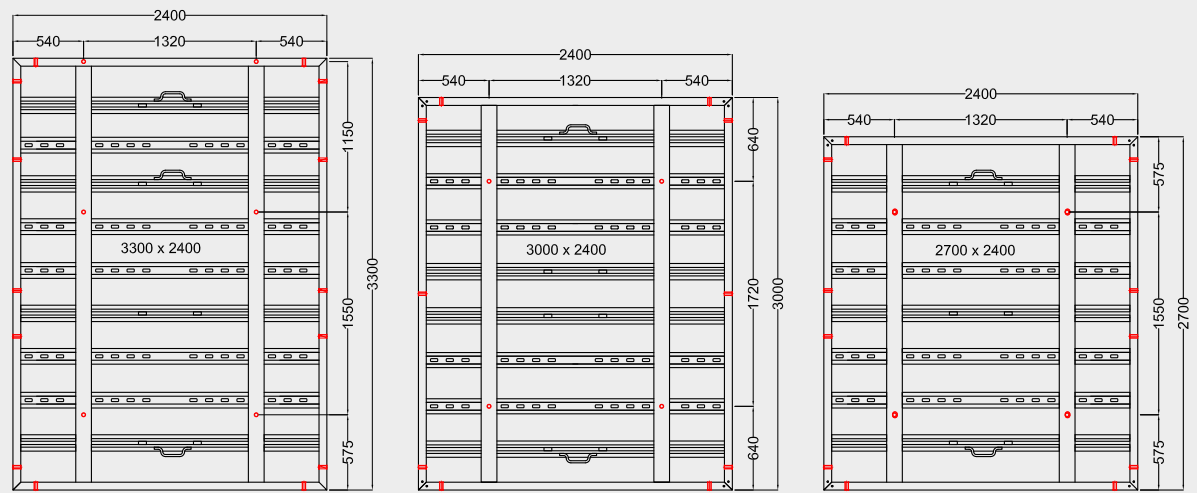

**UNIVERSAL PANELS**

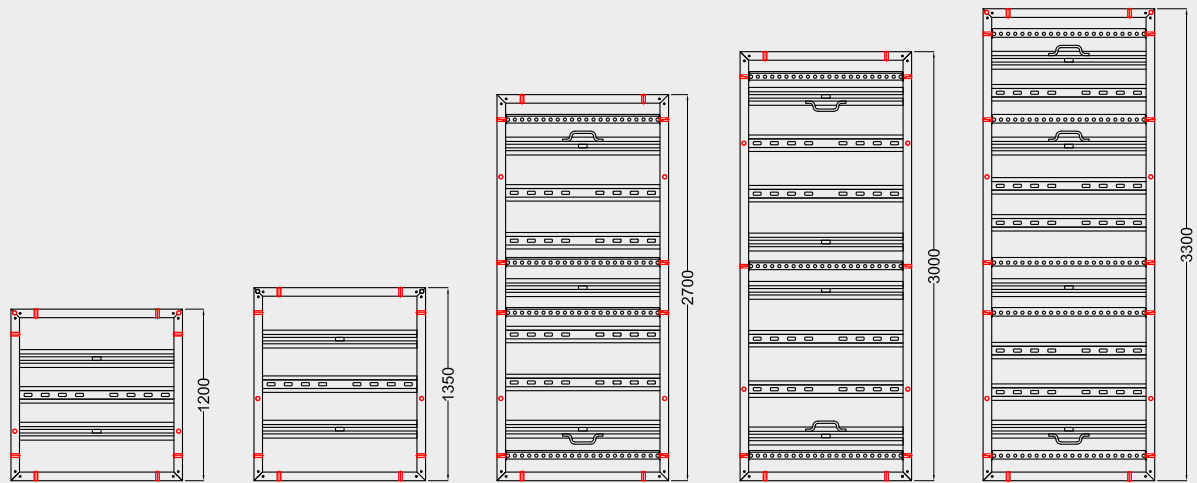

**COMBINATIONS**

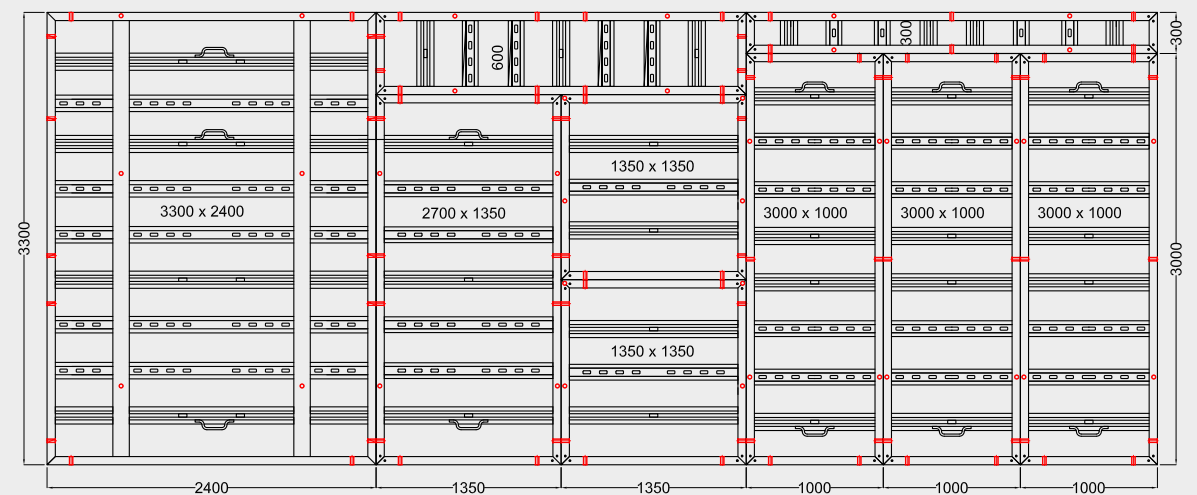

**SUPER DESTIL PANELS**

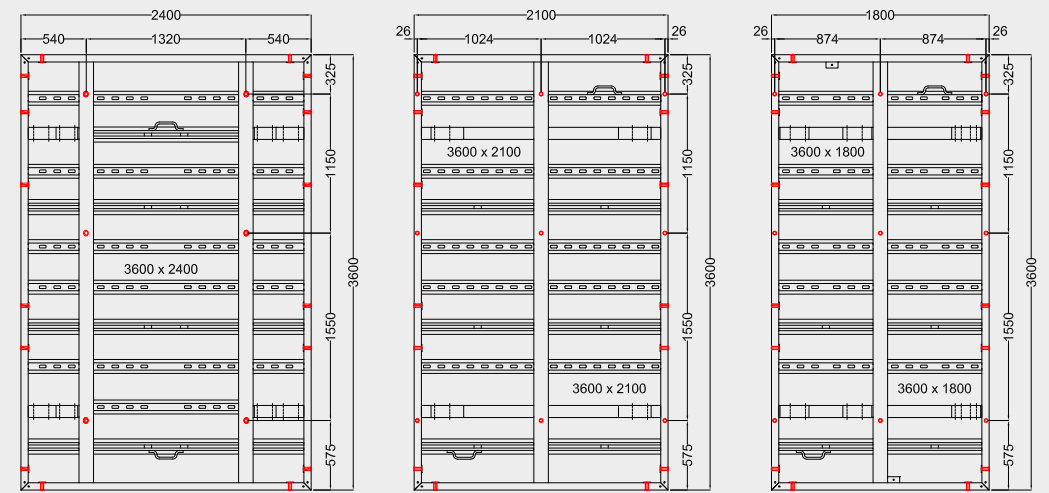

**SUPER DESTIL COMBINATIONS**

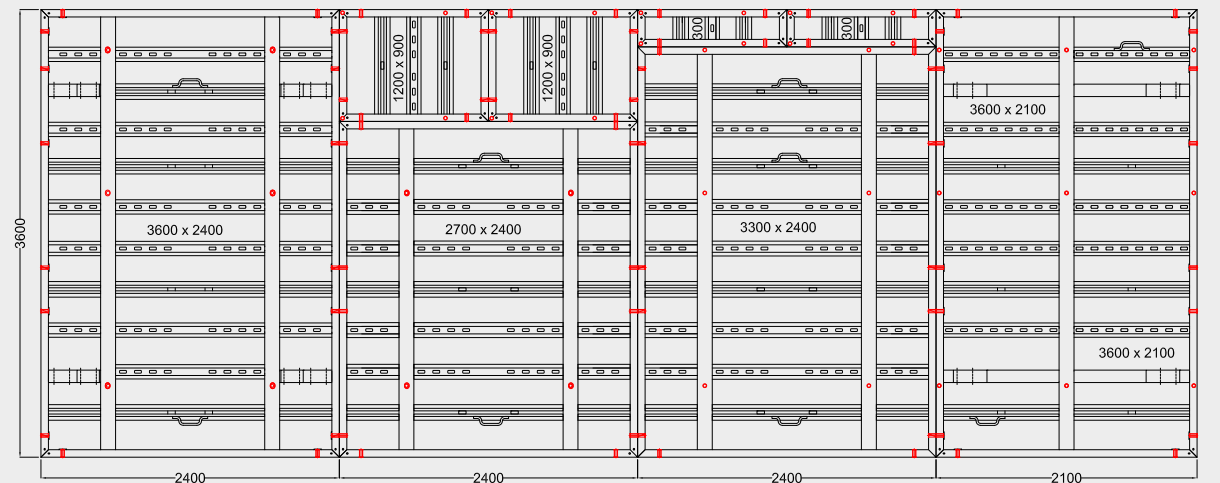

**SUPER DESTIL COMBINATIONS**

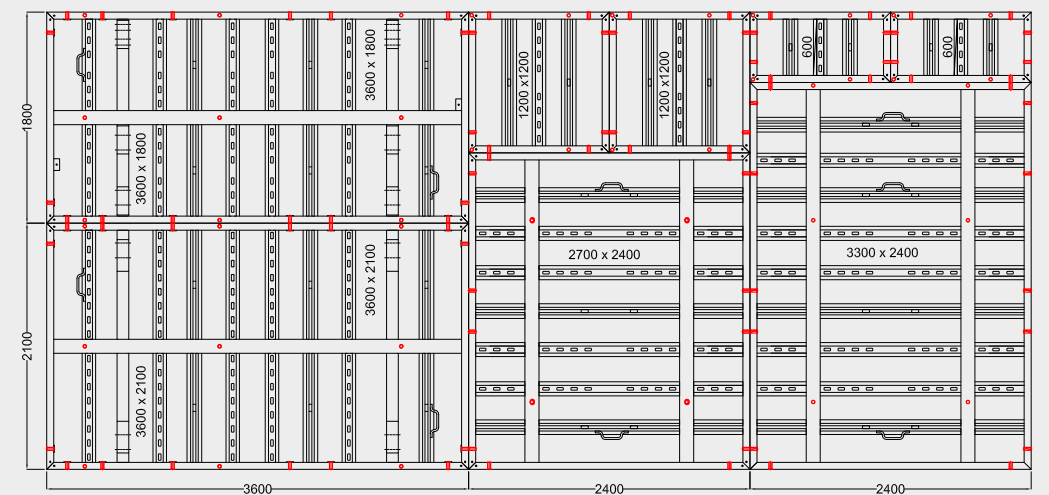

SUPER DESTIL FORMWORK PANEL CONNECTION

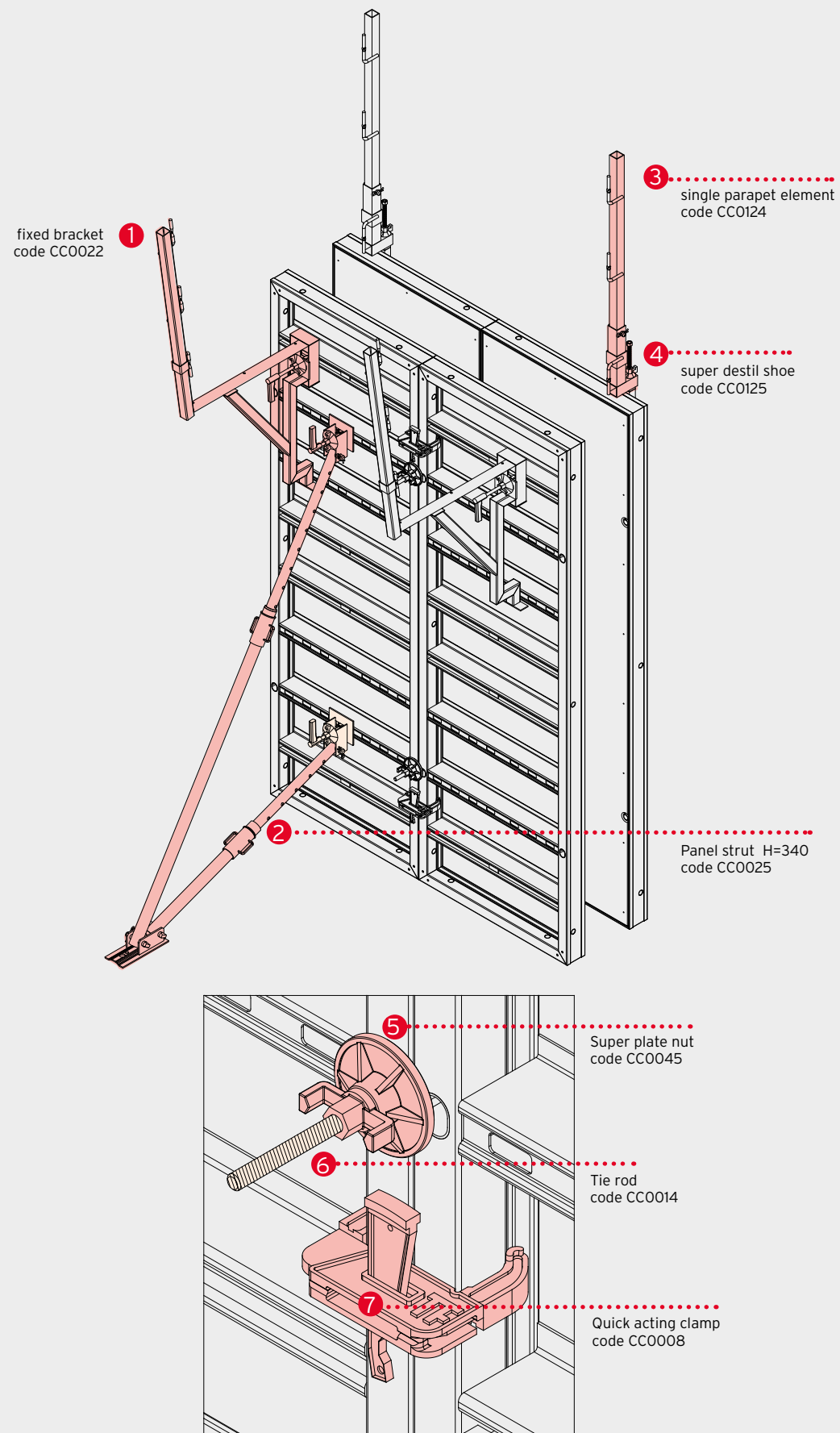

FIXED BRACKET

Should be used for construction of casting platforms or service platforms. Fixed bracket is joined to the formwork structure with appropriate fixing head. It is recommended to maintain the distance between two brackets no greater than 1.8 metres. Toe boards, midrails and top rails must be installed prior to accessing brackets. The access to the work platforms and casting platforms is granted with appropriate ladders. If the casting platform is mounted on the top of the formwork, even the other side of the bracket should be protected with appropriate parapet. Any other outer openings should be closed and blocked according to the local safety regulations.

Connection with formwork module

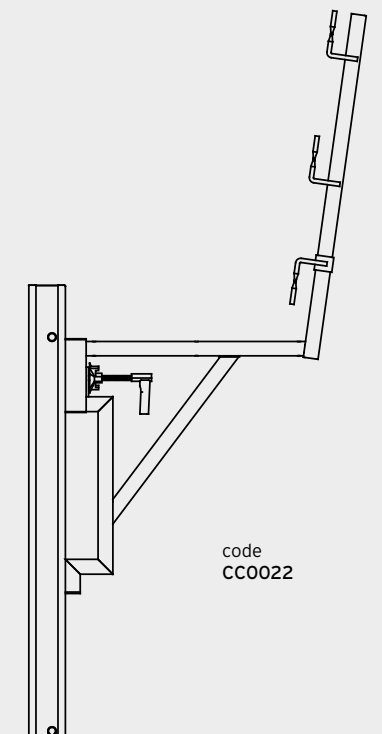
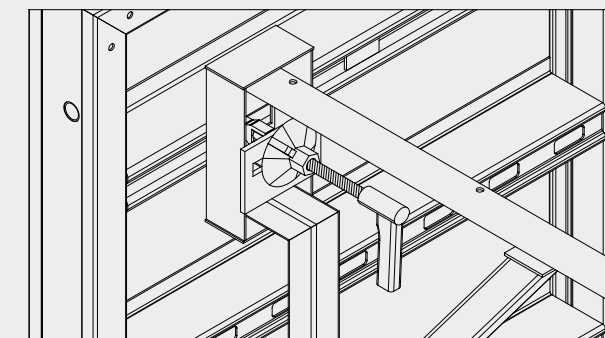

PANEL STRUT / PUSH PULL PROP

Panel struts allow the adjustment of formwork perfectly vertical and can reach up from 4.2 to 6.5 metres in height. With two telescopic arms; each of which has one Prop head which is suitable for anchorage to formwork at any point. The Prop shoe should be fixed to the ground in order to avoid turnover of the formwork.

Prop shoe

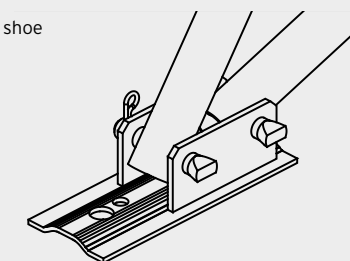

Connection with formwork

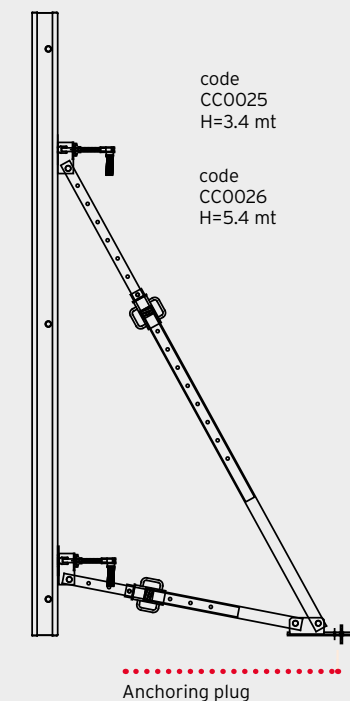
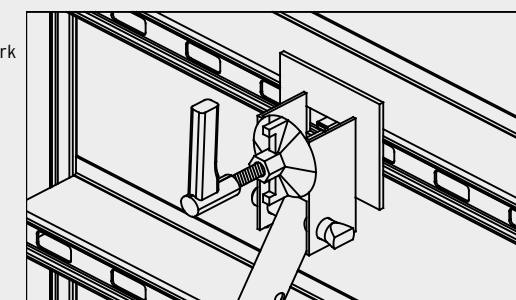



**PLATE NUT D15 (ø150)**

code  
CC0045

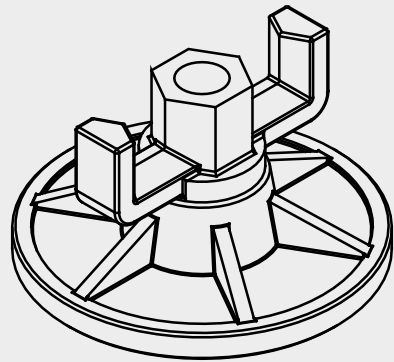

Screwed on the tie rods in order to lock up bindings (2 plates needed for each bar). Admissible load =90 kN (according to regulation DIN 18216).

**QUICK ACTING CLAMP**

Connect the adjacent formwork elements together using quick-action clamps at any point of the frame edge, preferably close to the stiffeners.

- Destil Quick Acting Clamp and Destil Multi Function Clamp:
- align perfectly the elements creating connections faster and resistant to traction
  - the wedge mechanism avoids clogging of concrete

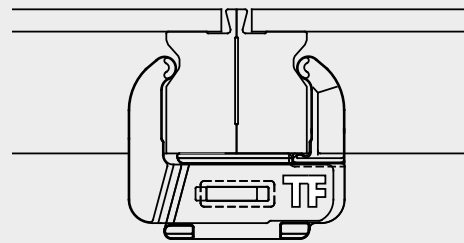

Fixes the formwork panels

code  
CC0008

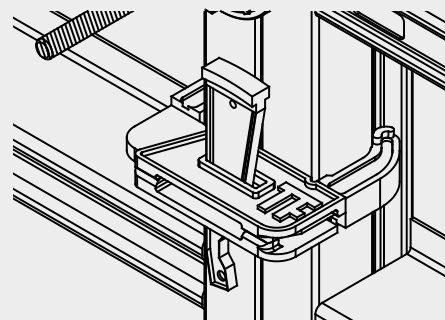

VERTICAL ELEMENTS		HORIZONTAL ELEMENTS	
Height elements (mt)	Fixing number	Height elements (mt)	Fixing number
1.20	2	0.30	1
1.35	2	0.45	1
2.70	2	0.60	2
3.00	2	0.90	2
3.30	2	1.35	2

- Permitted tensile force: 15.0 kN
- Permitted shear force: 6.0 kN
- Moment: 0.5 kNm

Thanks to the notch that runs along the frame profile, the connection of elements may occur at any point. This allows a continuous junction in height of elements in any position.

**TIE ROD**

Used to fix corresponding formwork during the casting operations. Produced in standard length of 6 metres and cut to necessary length on the construction site. The bars can be reused after the works; but prior to casting, they should be put in plastic tube, type 22/26, and then can be reused. For correct usage the bar should be equipped with appropriate accessories (Super plate nuts or Hexagon nuts or Plate nuts D15). Admissible load: 90 kN (according to regulation DIN 18216) Ultimate load: 190 kN (according to regulation DIN 18216). Admissible load: 120 kN (with 1.6 safety factor).  
NOTE: To avoid rupture or deformations, the bars should not be warmed-up or welded.

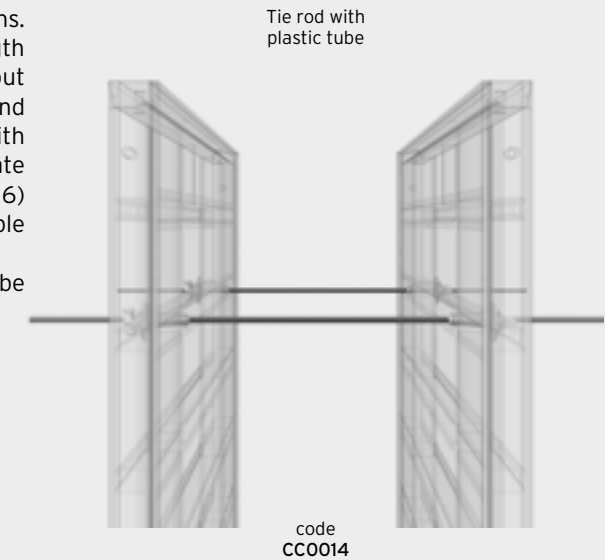

**EXAMPLE**

EXAMPLE OF DIFFERENT FORMWORK STARTING POINTS. The presence of conic holes permits connecting two formwork modules with different starting points.

Example of anchorage with one inclined wall side.

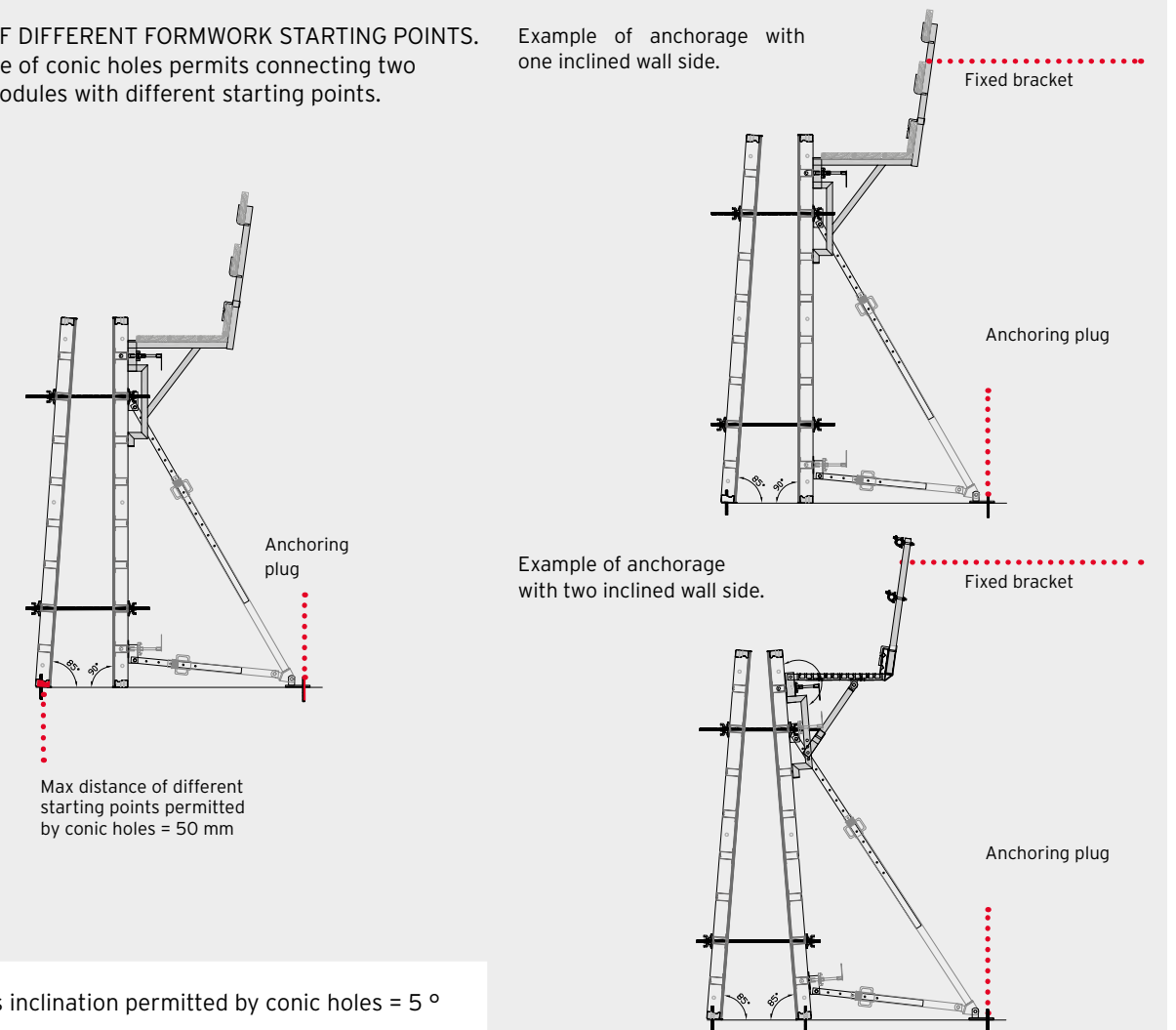

MAX wall side's inclination permitted by conic holes = 5 °

SUPER DESTIL : TIE RODS COMPATIBILITY

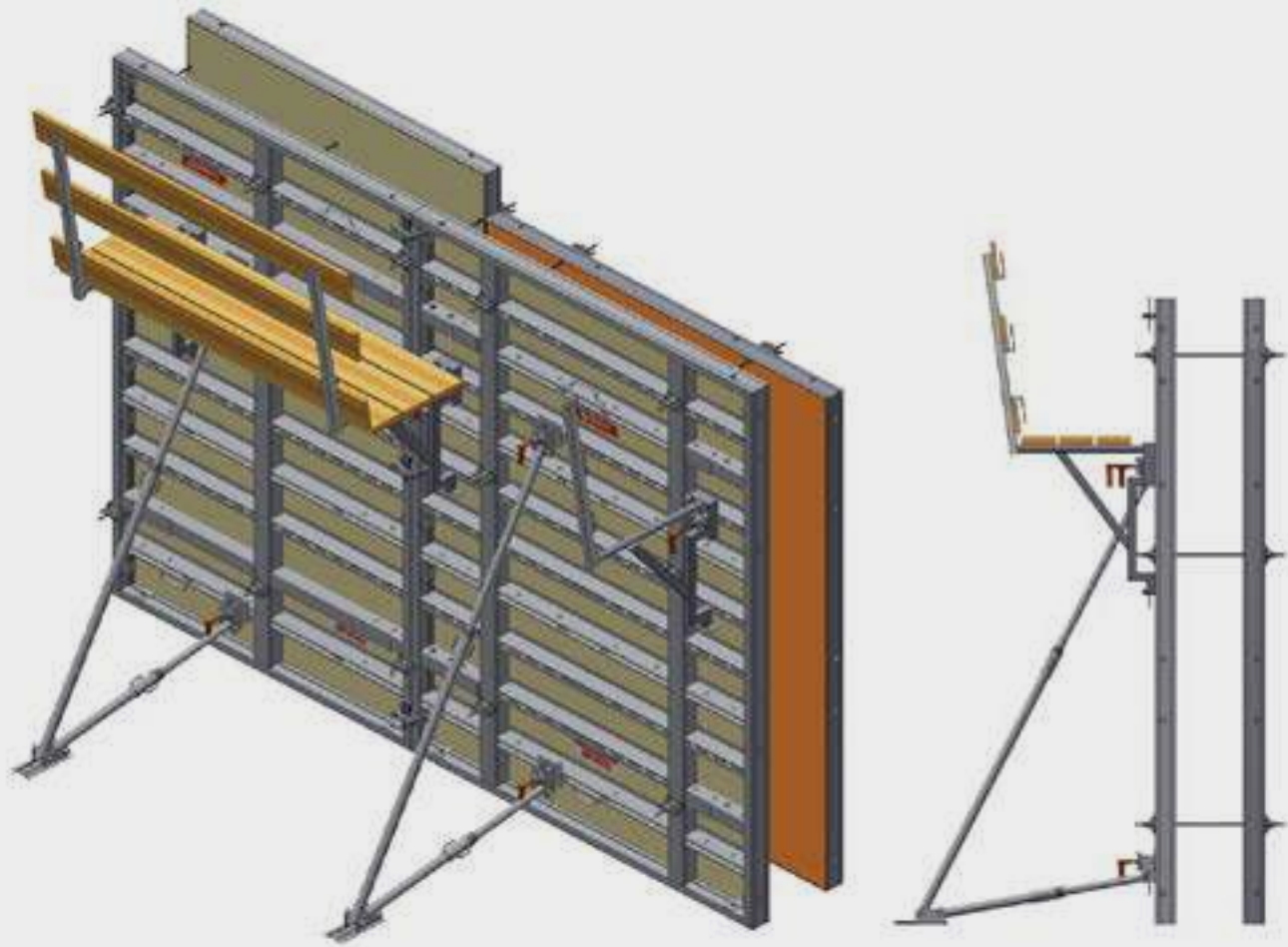

Typical wall assembly layout with plumbing struts and pouring brackets.  
 SUPER DESTIL elements can be used in combination (opposite) with standard DESTIL elements due to the same tie-rod layout (same tie-rods step in height for 3300 and 2700 range).

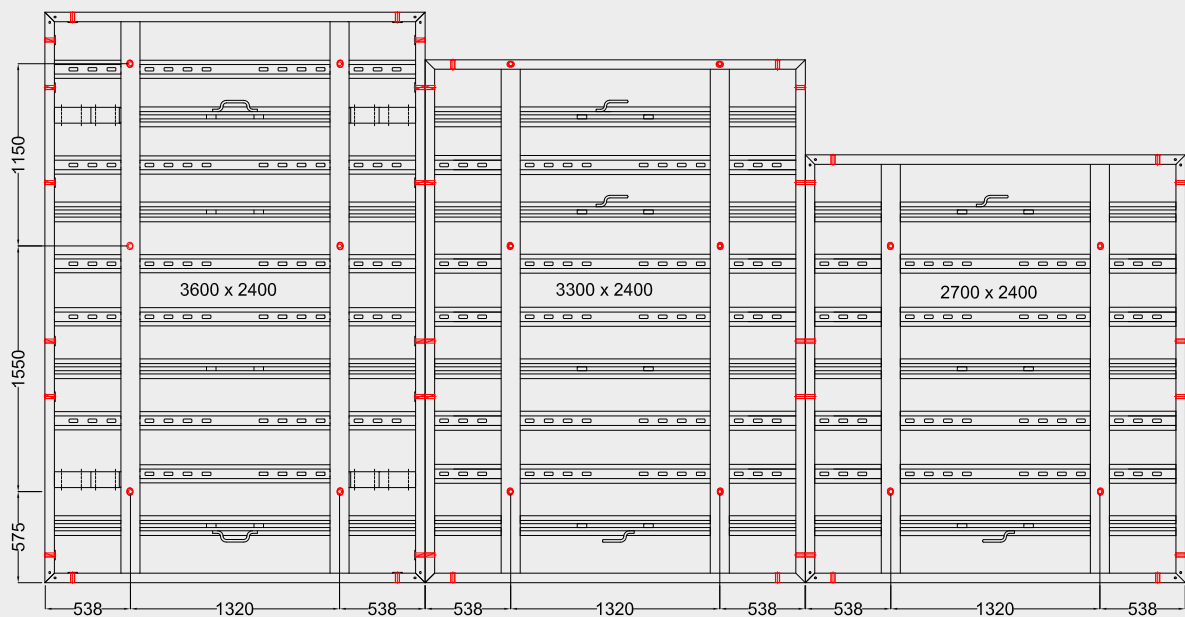

SUPER DESTIL - SLAB ACCESSORIES

SUPER DESTIL PARAPET - USE IN WALL CONFIGURATION

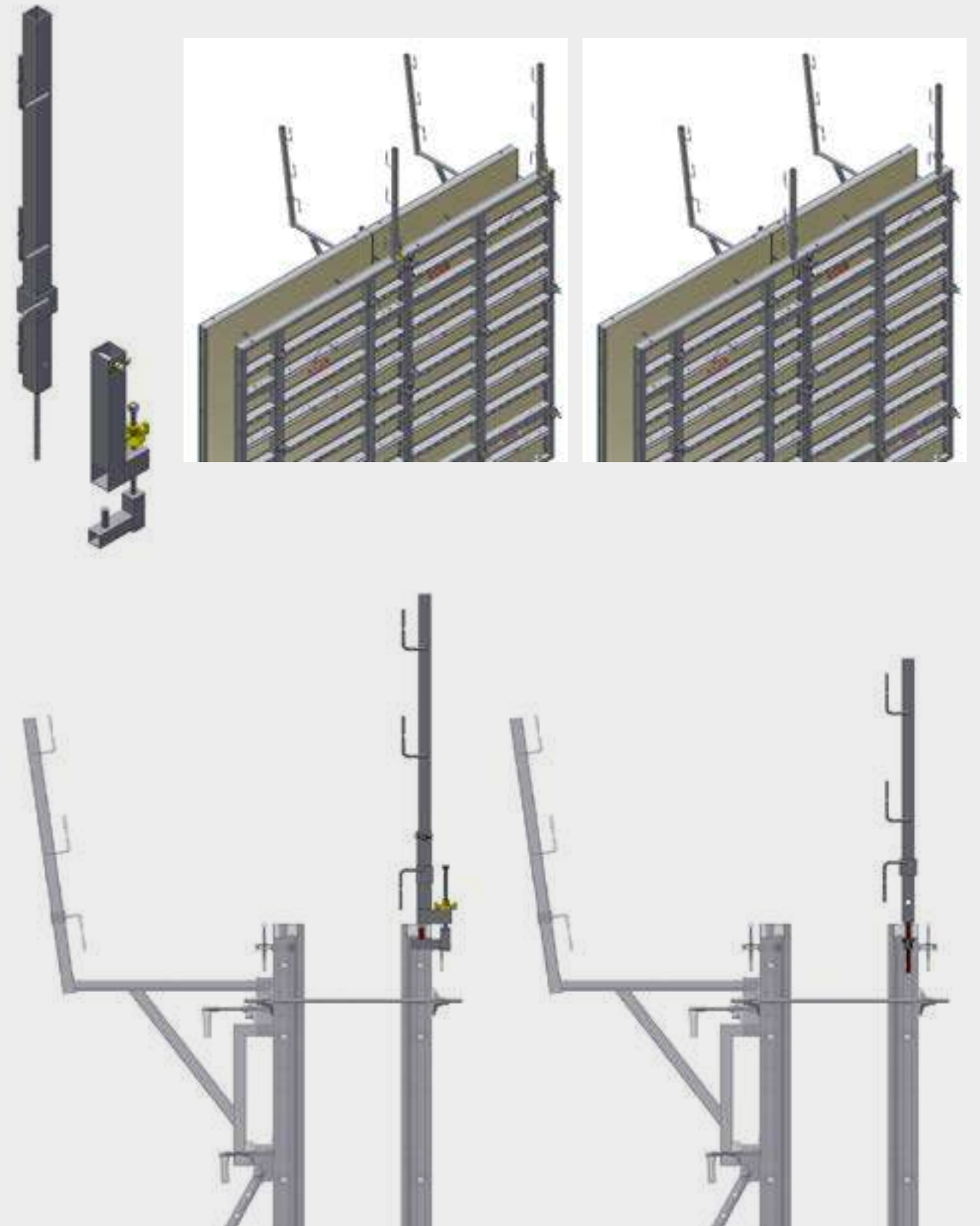

DESTIL FORMWORK ELEMENT CONNECTION

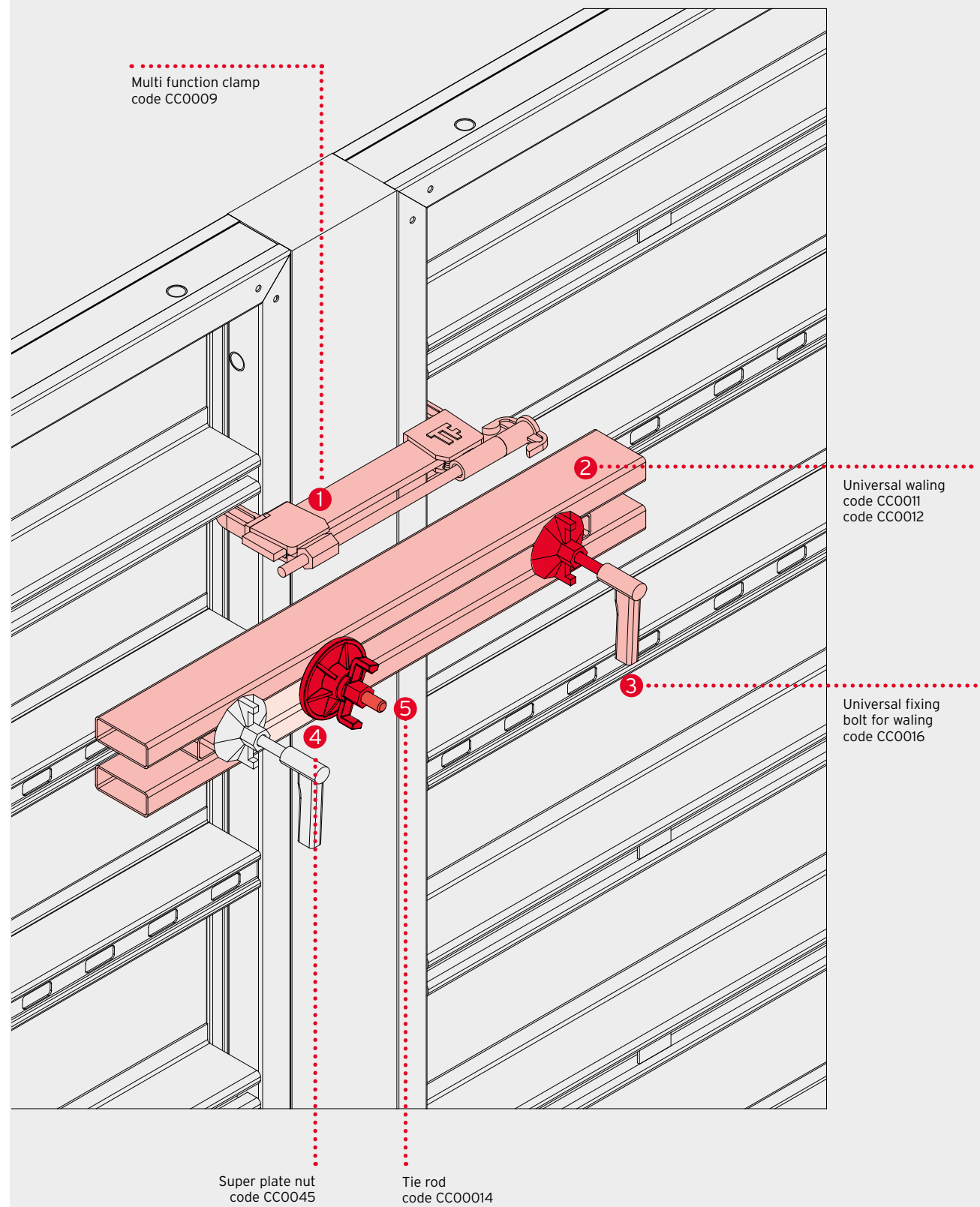

CLOSURES UP TO 200 mm

Wall compensation from 0 to 200 mm using wooden beam or wooden boards, multi function clamp for the connection of the elements and universal waling for alignment.

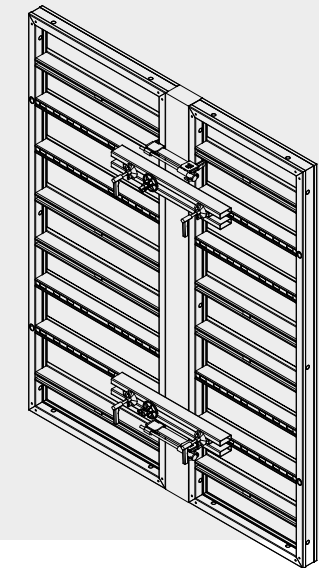
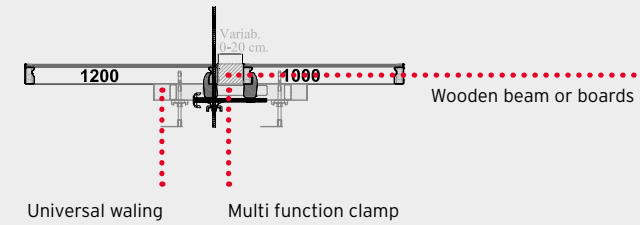

CLOSURES UP TO 600 mm

Wall compensation from 0 to 600 mm using wooden boards or wooden panels.

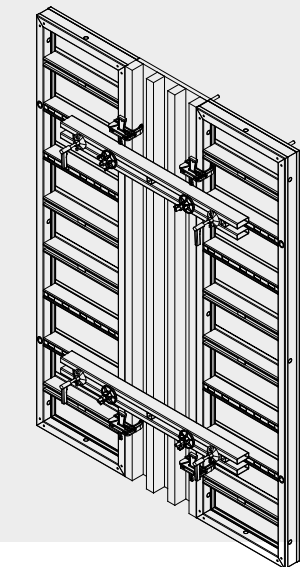
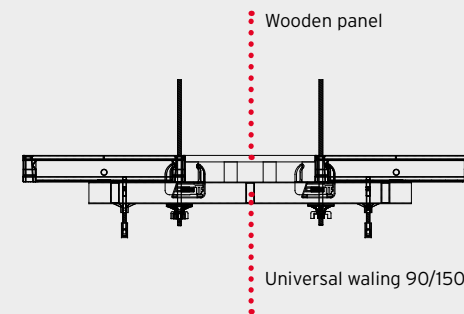

UNIVERSAL WALING DETAILS

Connection of the universal waling to the framework using the universal fixing bolt for waling and omega profile.

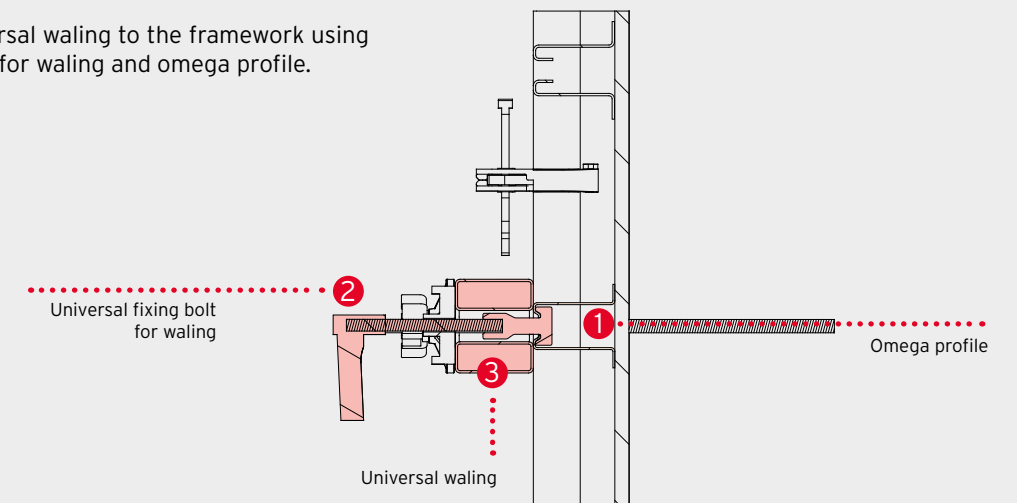



PANEL STRUTS H=3400 mm | PUSH / PULL PROPS

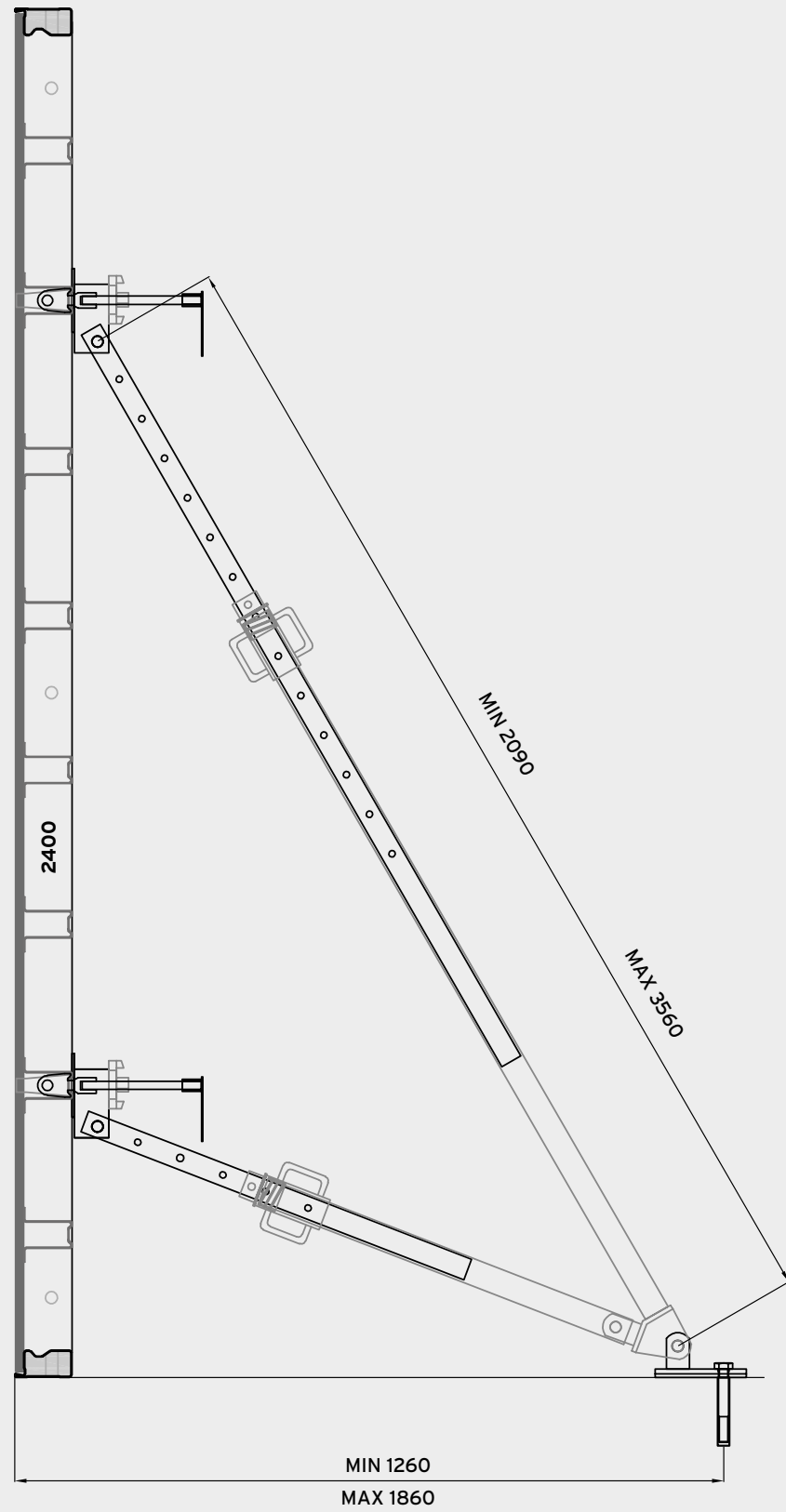

Panel struts used for plumbing and installation operations.  
Panel Strut H=3400 mm: minimum and maximum possible extension.

MAXIMUM STRESS OF THE PANEL STRUT H=3400 mm | PUSH / PULL PROP

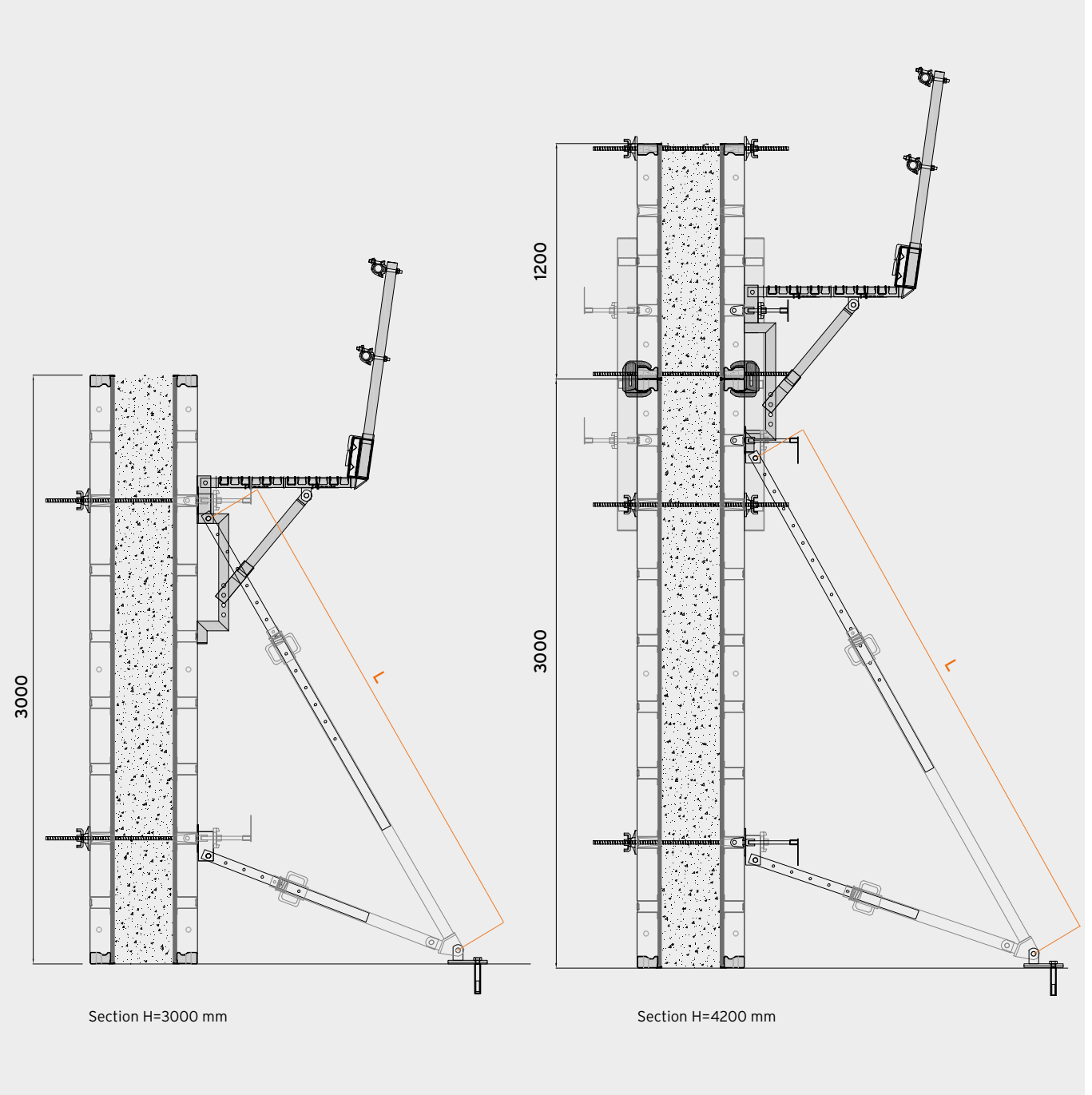

ELONGATION L (MT)	COMPRESSION EFFORT (KN)	TENSILE EFFORT (KN)
2.0	22.0	<b>15.0</b>
2.2	21.0	
2.4	17.5	
2.6	14.5	
2.8	12.5	
3.0	11.0	
3.2	9.5	
3.4	8.0	
3.6	7.0	



PANEL STRUTS H=5400 mm | PUSH / PULL PROP

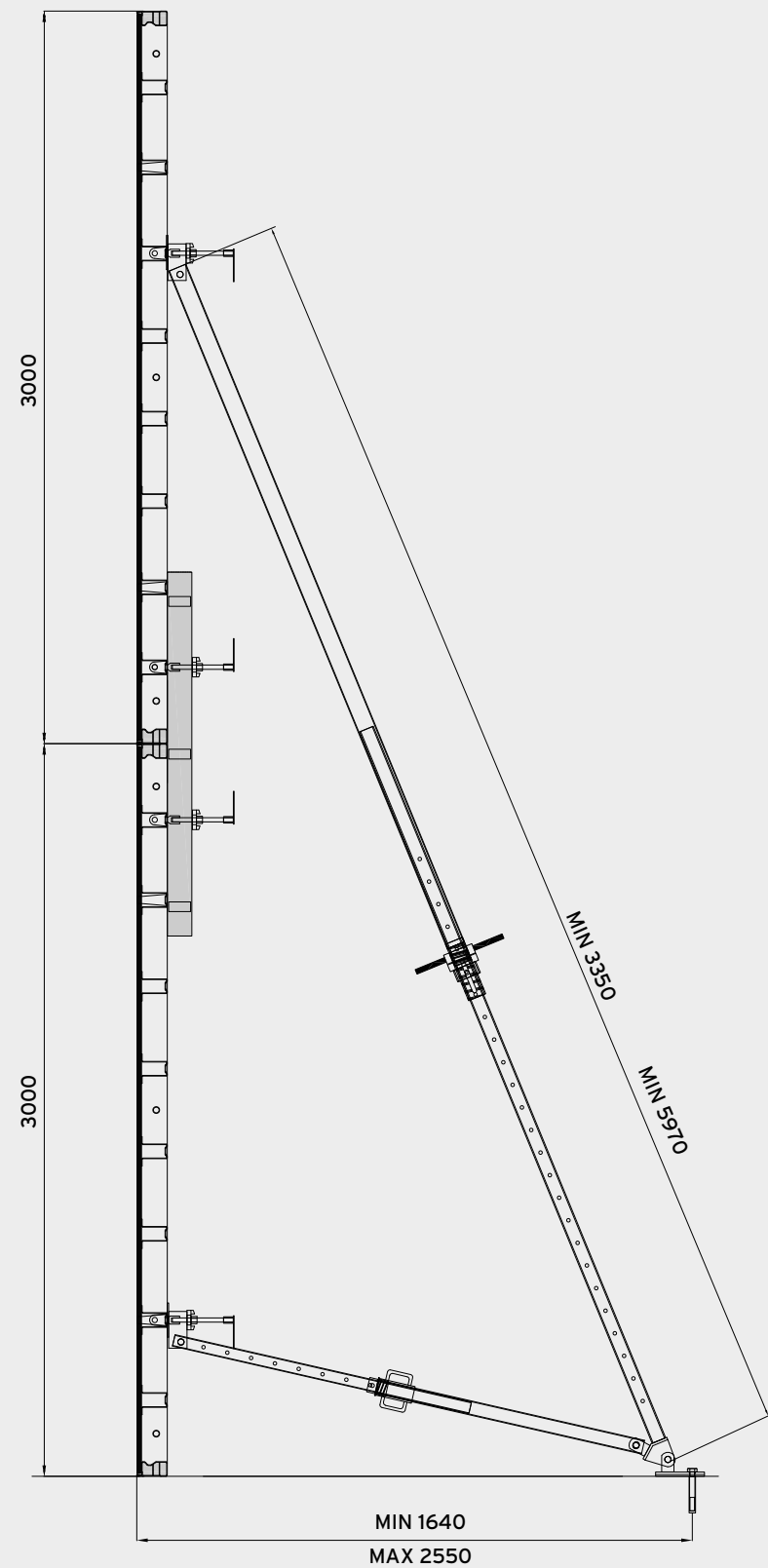

Panel struts used for plumbing and installation operations.  
Panel strut H=5400 mm: minimum and maximum possible extension.

MAXIMUM STRESS OF THE PANEL STRUT H=5400 mm | PUSH PULL PROP

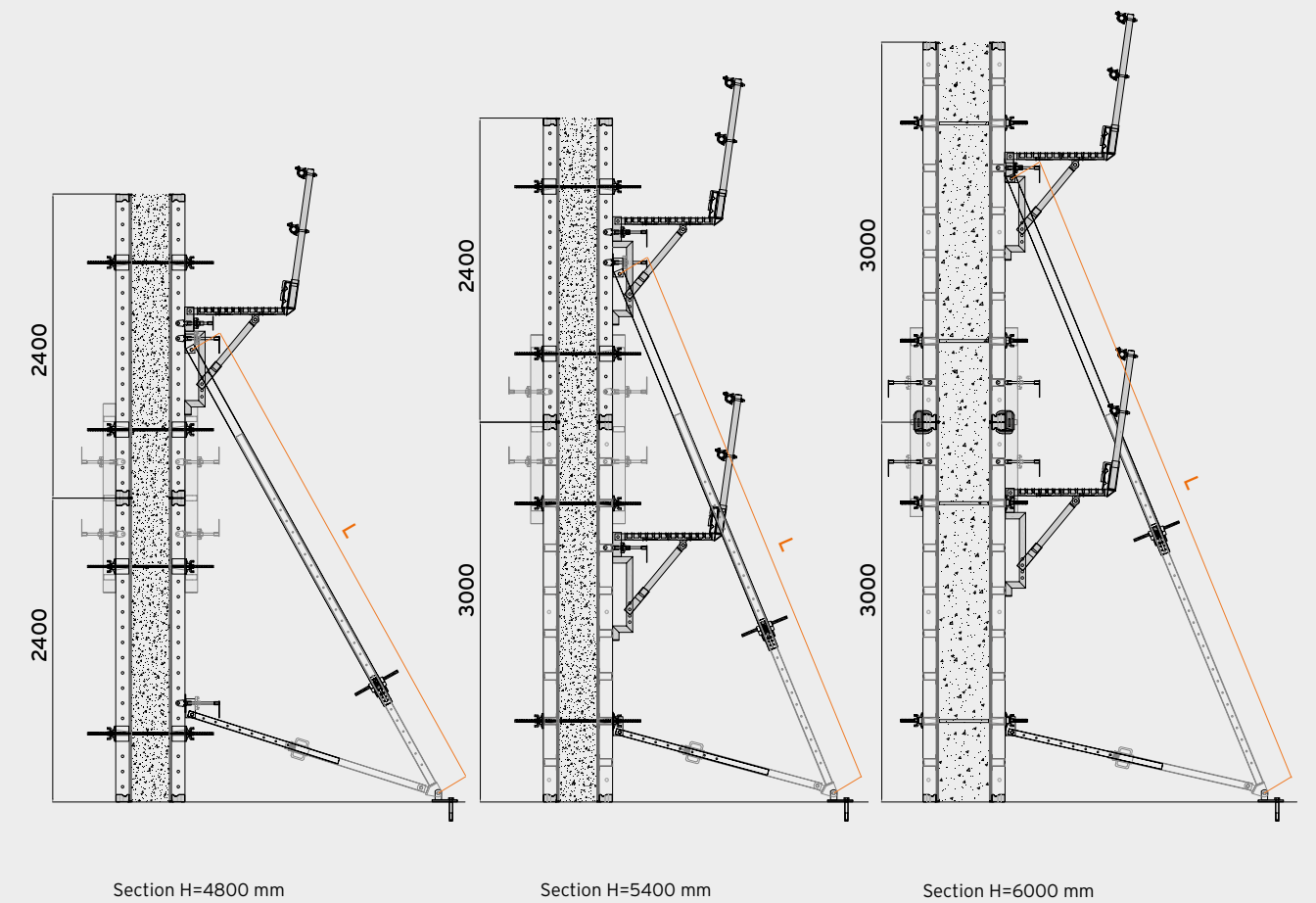

ELONGATION L (MT)	COMPRESSION EFFORT (KN)	TENSILE EFFORT (KN)
3.4	30.0	<b>30.0</b>
3.6	30.0	
3.8	25.0	
4.0	21.5	
4.2	19.0	
4.4	16.5	
4.6	15.0	
4.8	13.5	
5.0	12.0	
5.2	11.0	
5.4	10.0	
5.6	8.8	
5.8	7.5	
6.0	6.0	

90° ANGLE USING UNIVERSAL FORMWORK MODULE (900) AND COMPENSATION

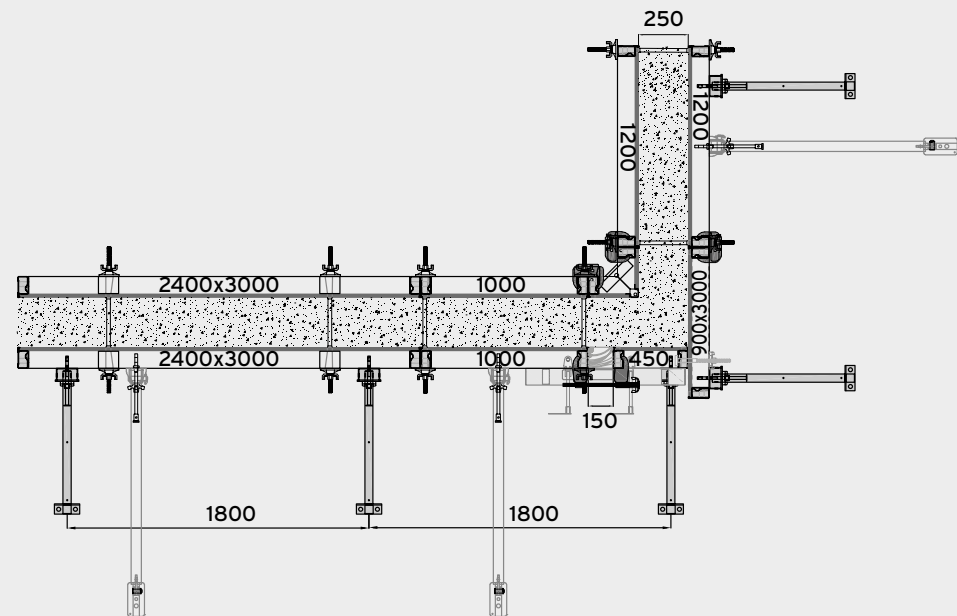
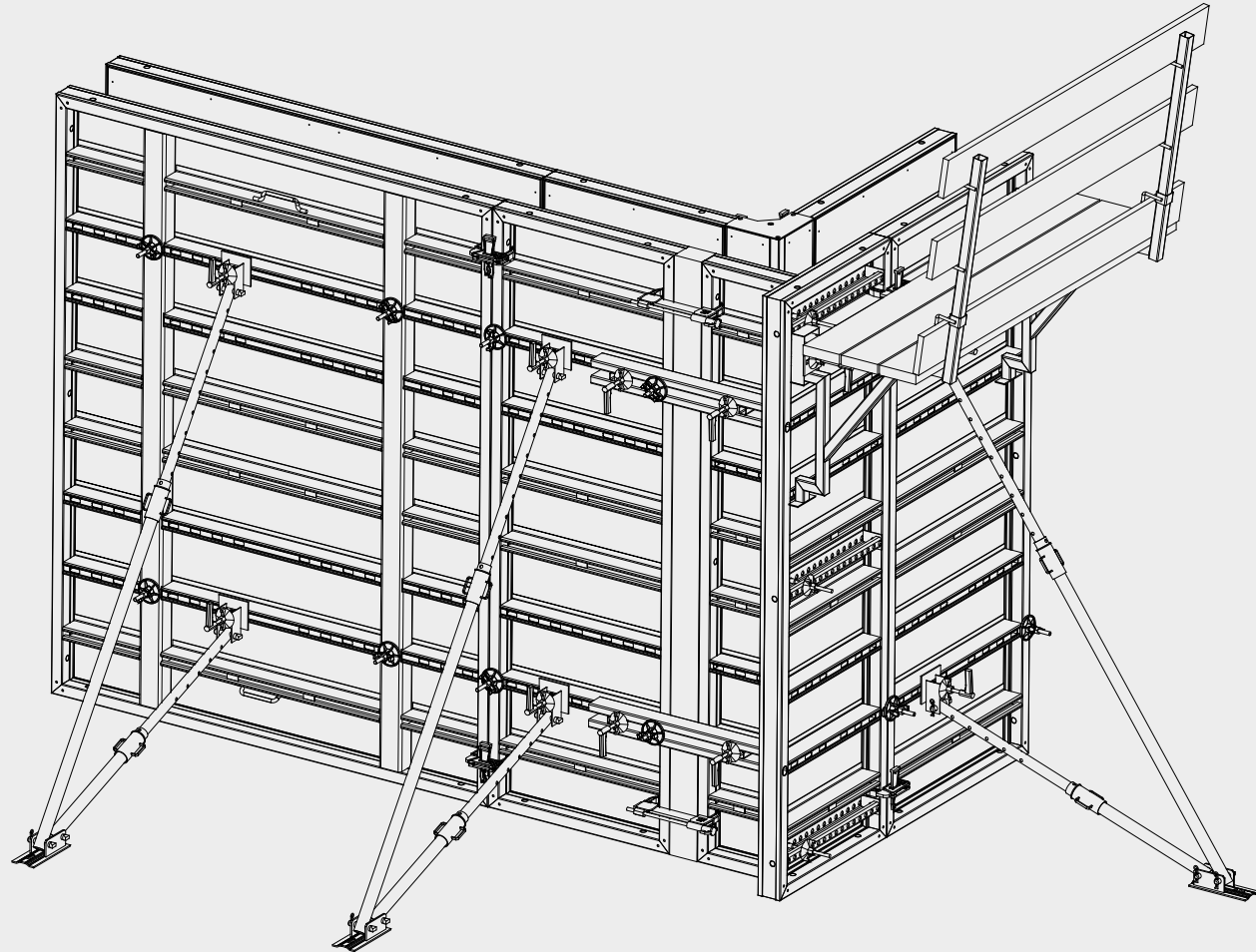

90° ANGLE WITHOUT COMPENSATION (USING ANGULAR FORMWORK ELEMENTS)

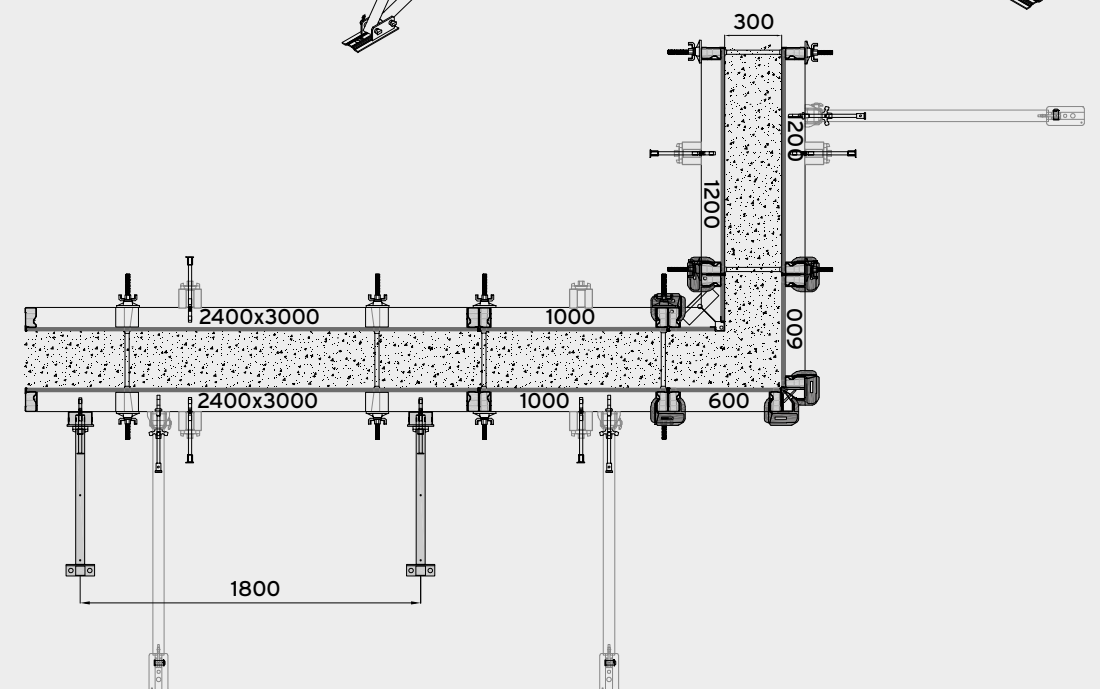
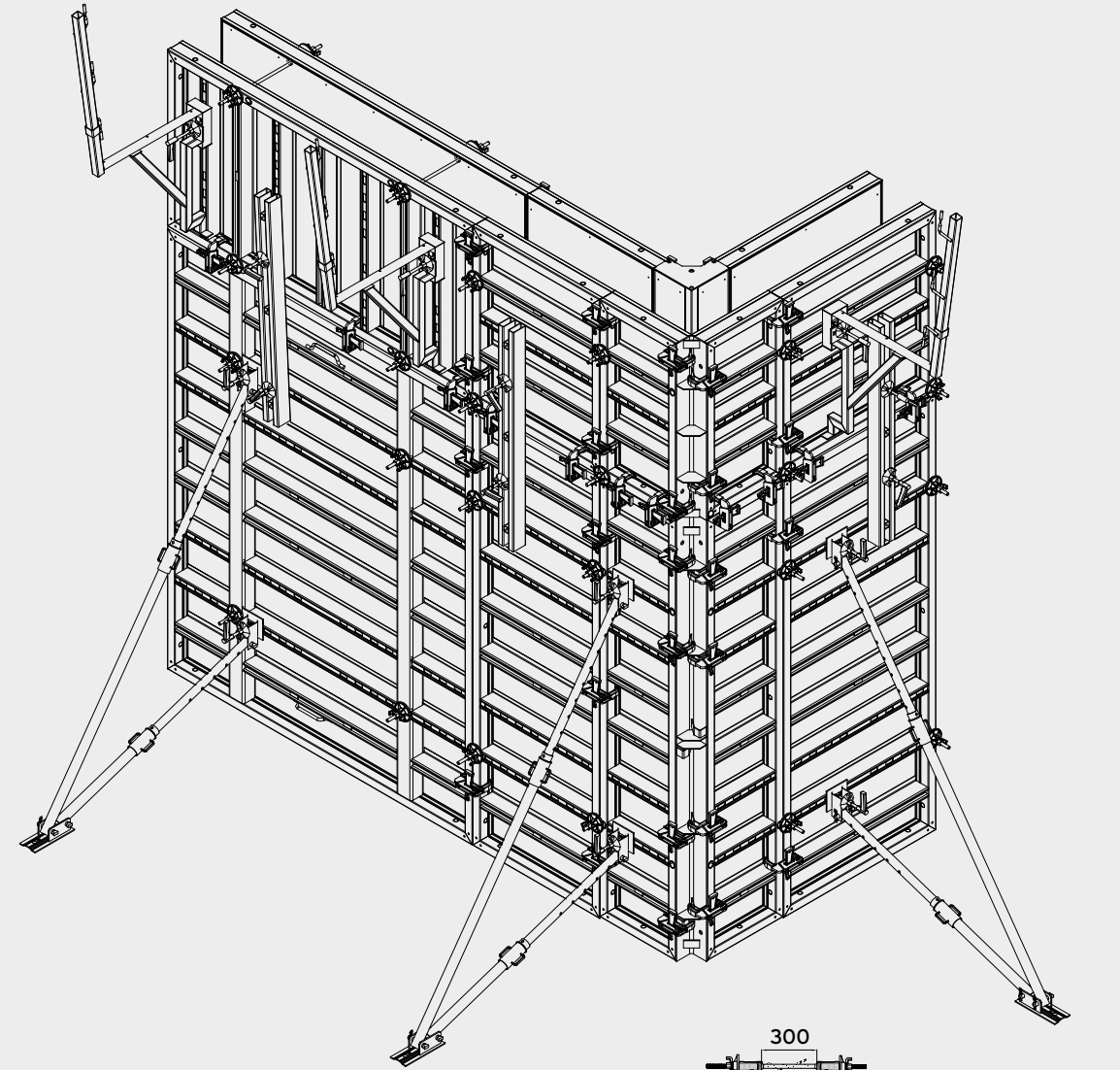

EXAMPLE OF ACUTE ANGLE

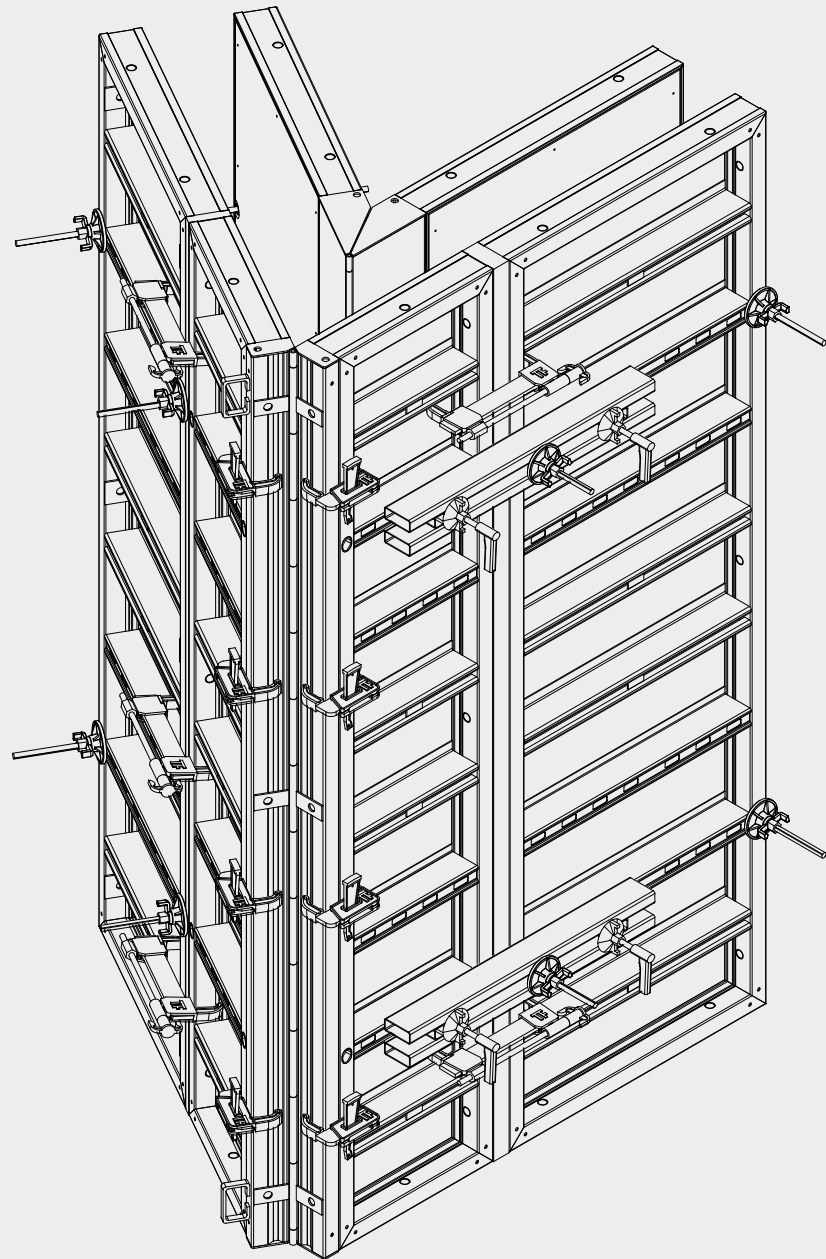
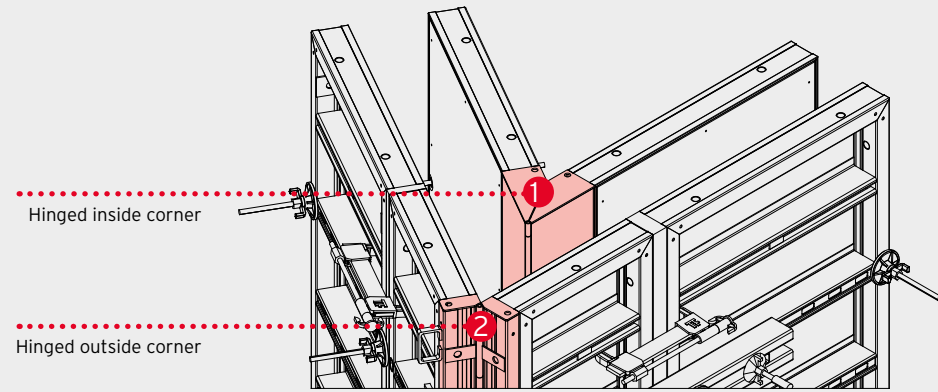

EXAMPLE OF ACUTE ANGLE

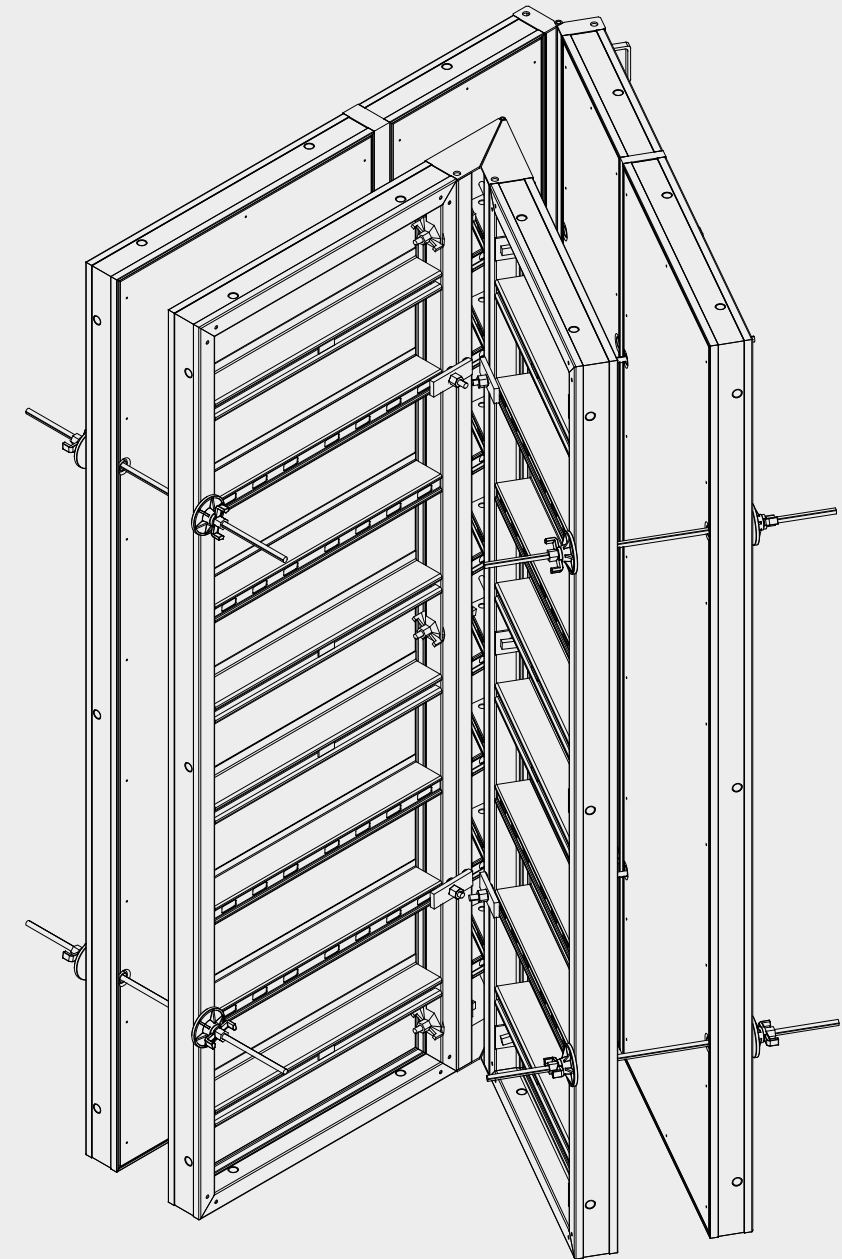
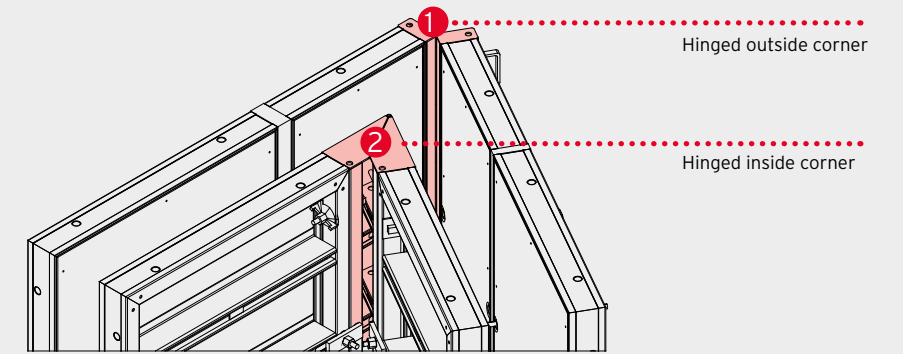



EXAMPLE OF 60° ANGLE

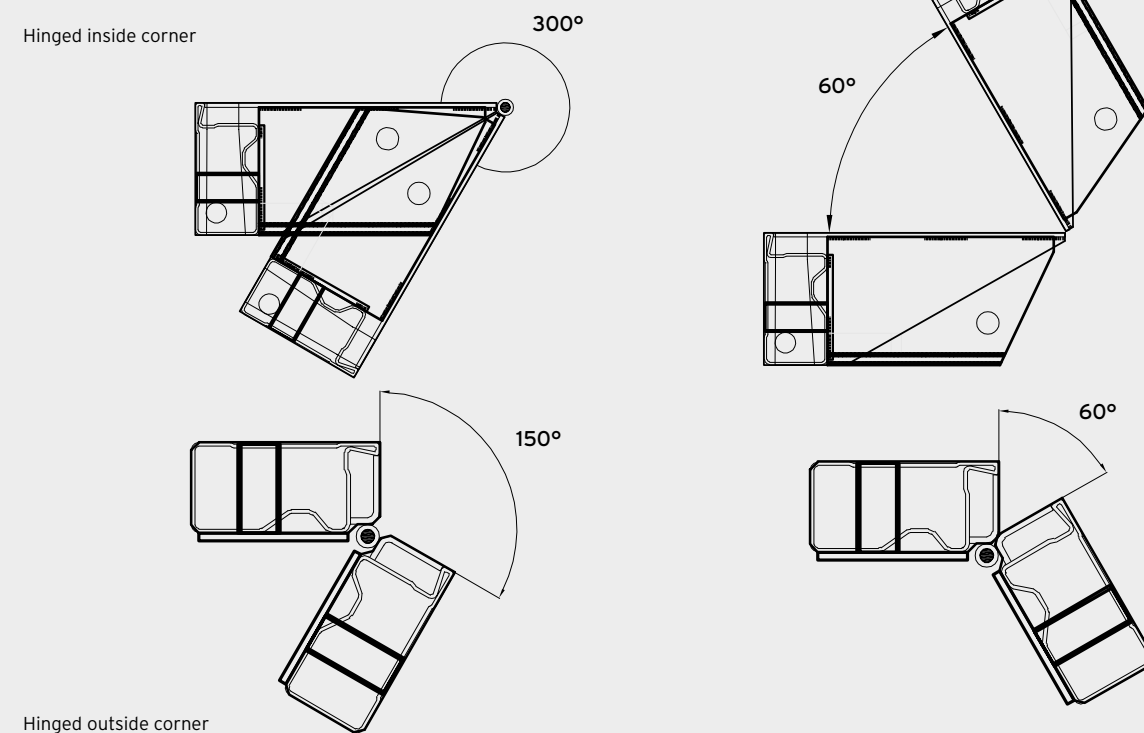
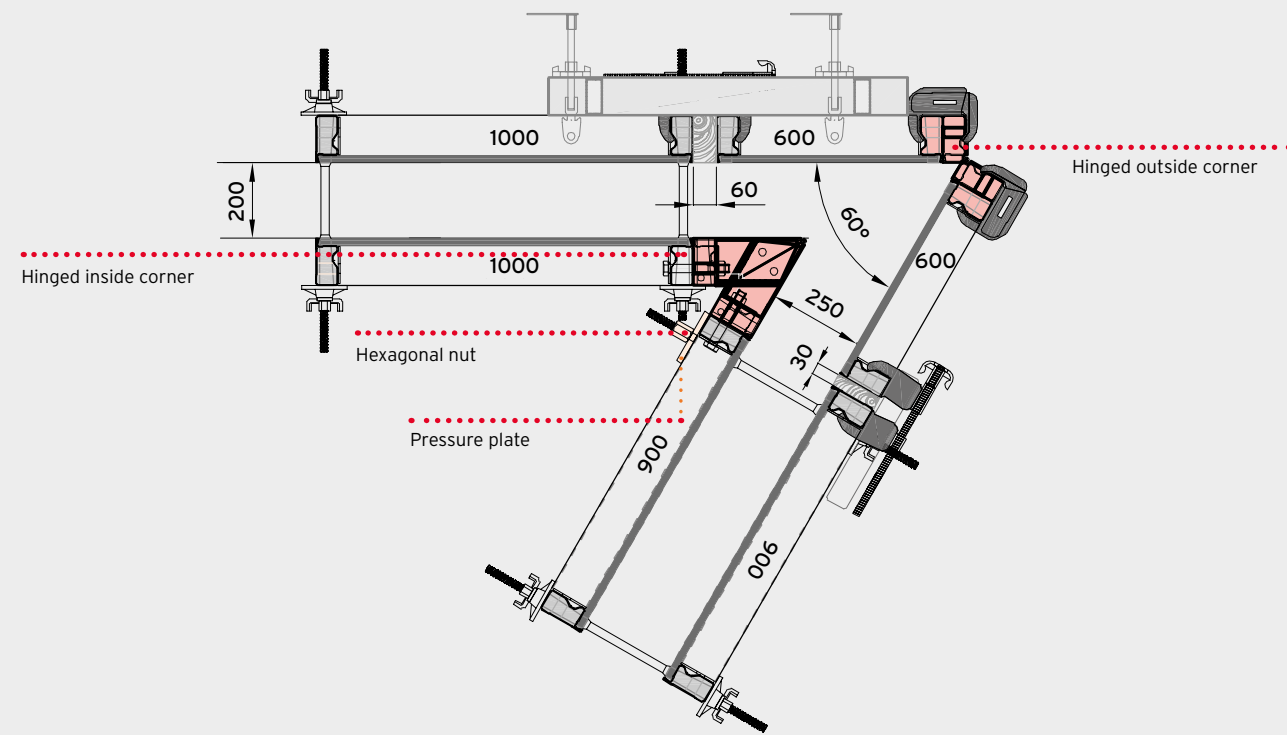

60° angle made using destil hinged inside and outside corners.

150° ANGLE

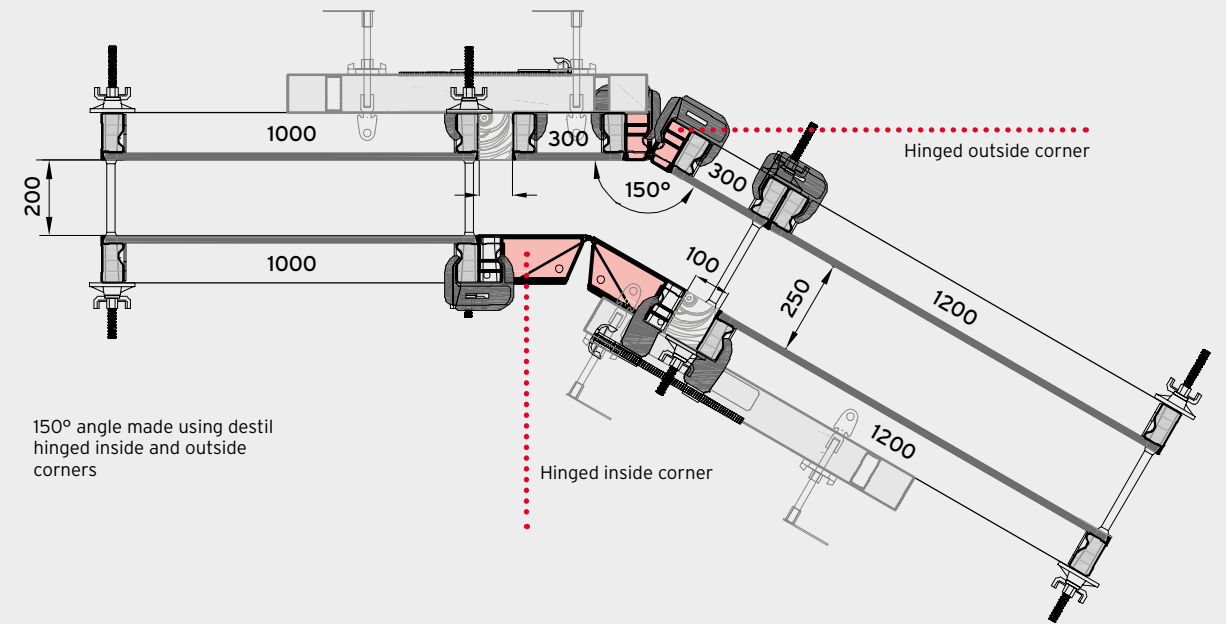

150° angle made using destil hinged inside and outside corners

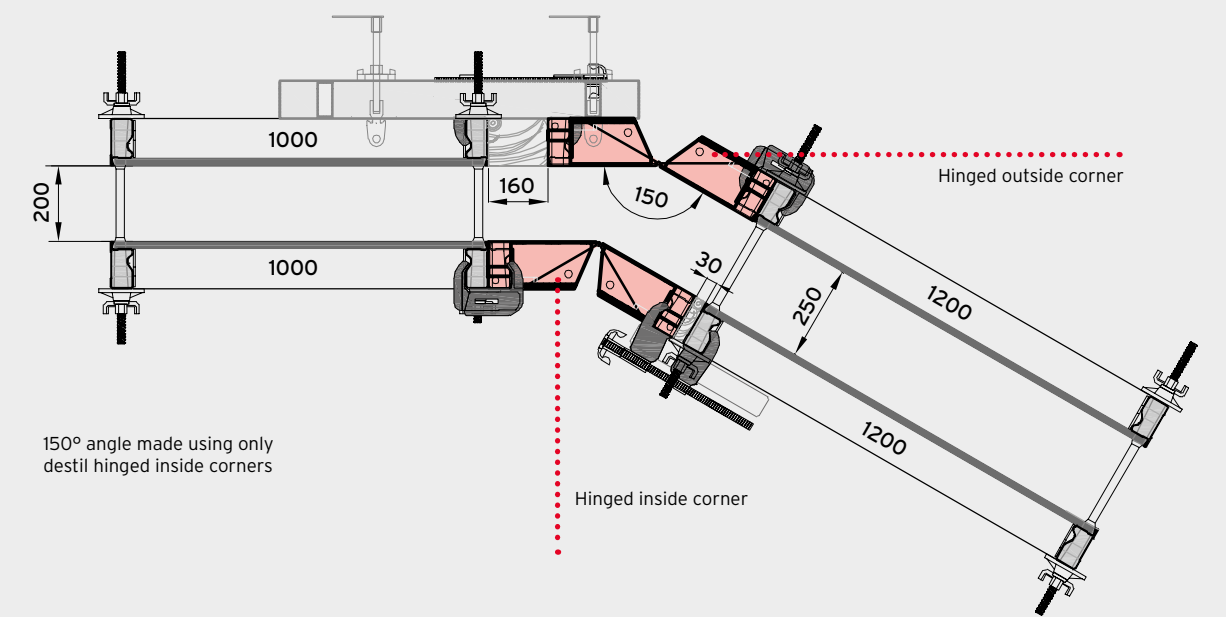

150° angle made using only destil hinged inside corners

STOP ENDS BY UNIVERSAL WALING

Closure using universal waling and stop-end tie clamp.

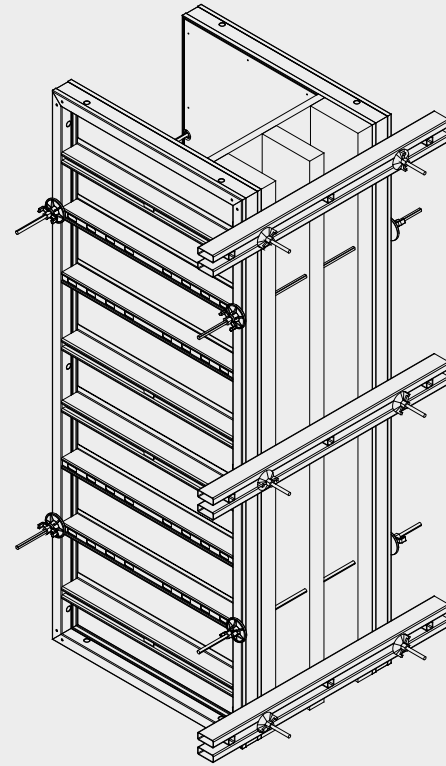

STOP ENDS BY UNIVERSAL ELEMENT

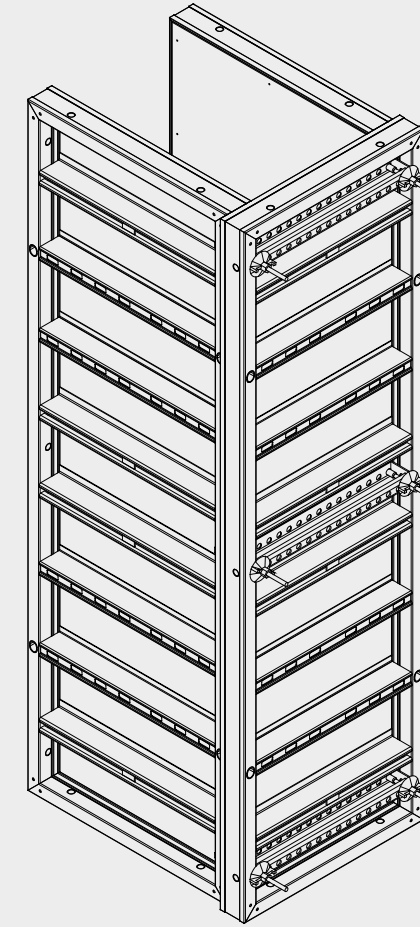

CLOSURE

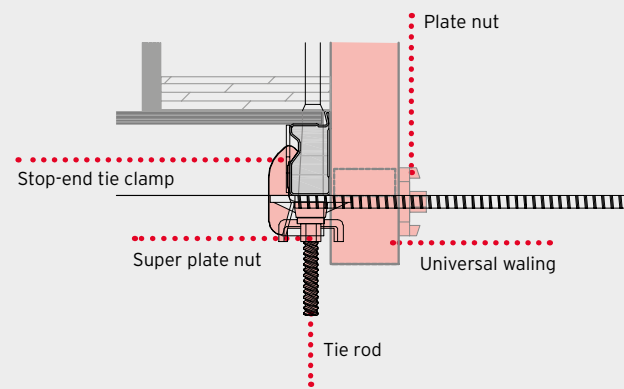
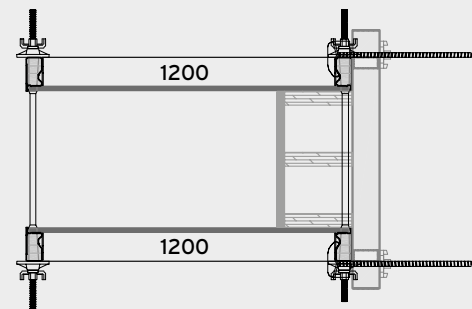

Closure of parallel formwork with wooden panels and wooden boards.

CLOSURE

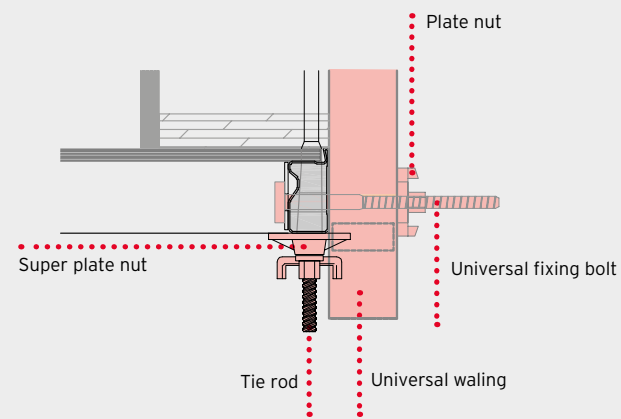
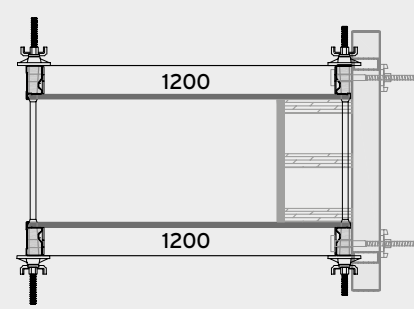

Closure using universal waling and universal fixing bolt.

Closure using universal fixing bolt

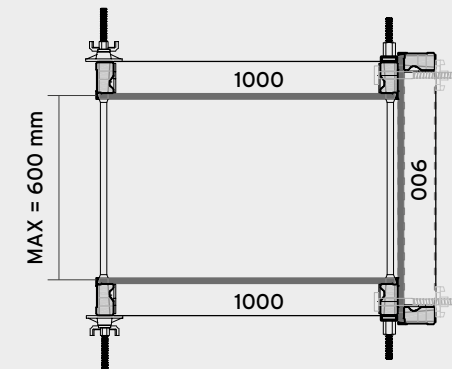

For fixing the universal column formwork every lateral hole of formwork module should be used

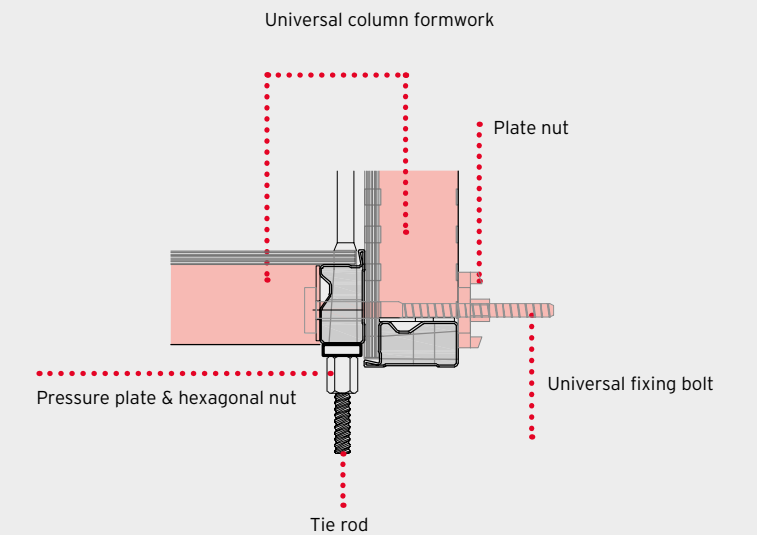

Closure of parallel formwork with universal column formwork.

STOP ENDS BY STANDARD ELEMENT & UNIVERSAL WALING

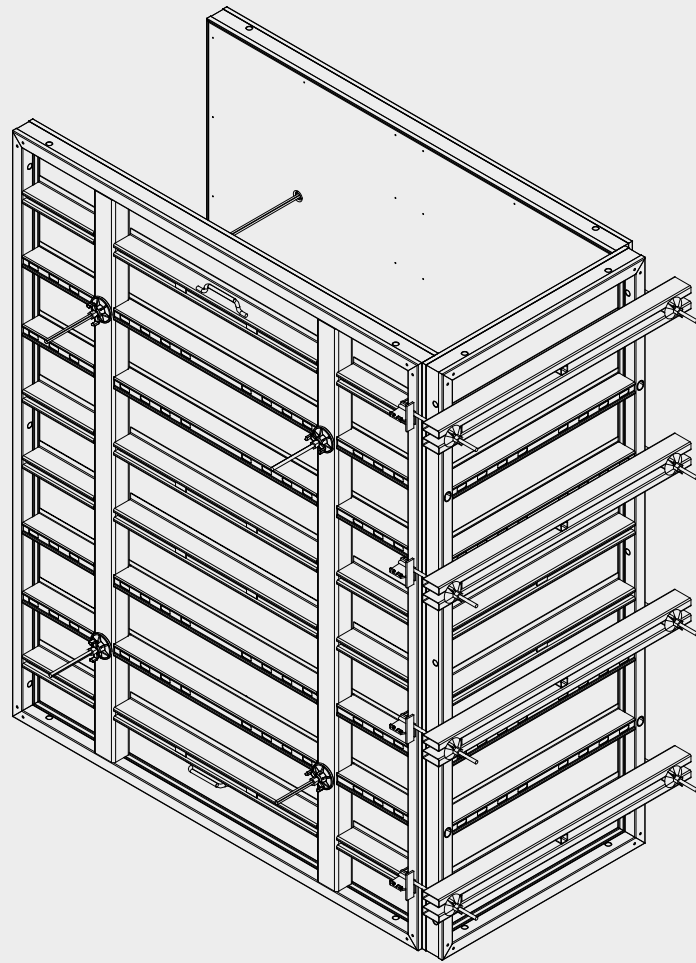

Closure using universal waling and stop-end tie clamp

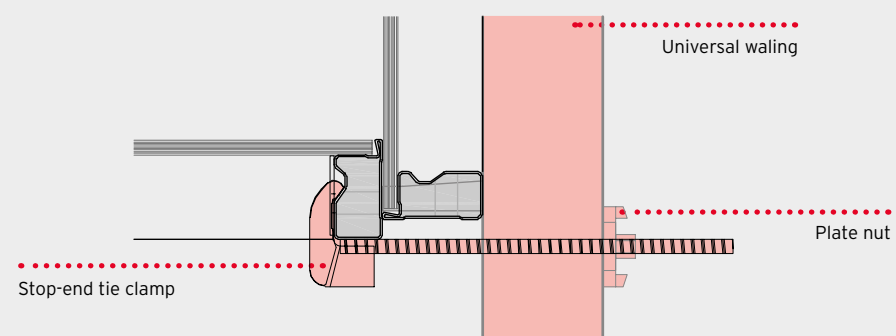

Closure of parallel formwork with wall formwork.

WALL OFFSET SOLUTION

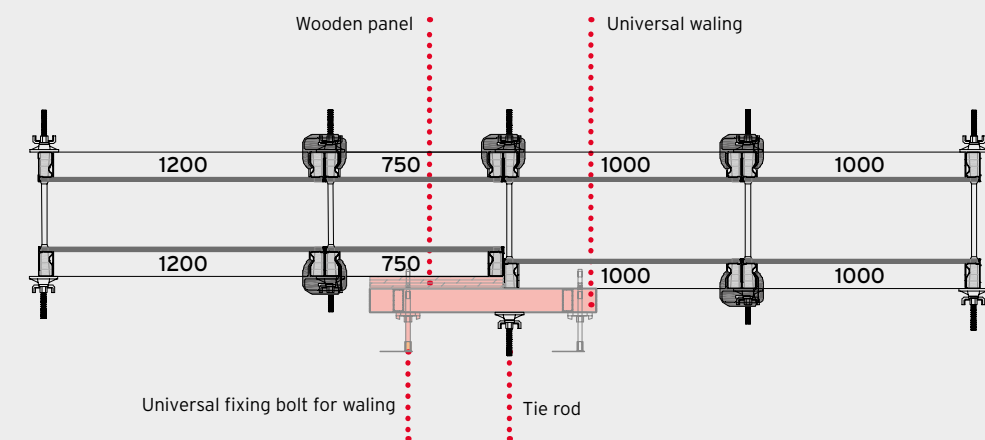
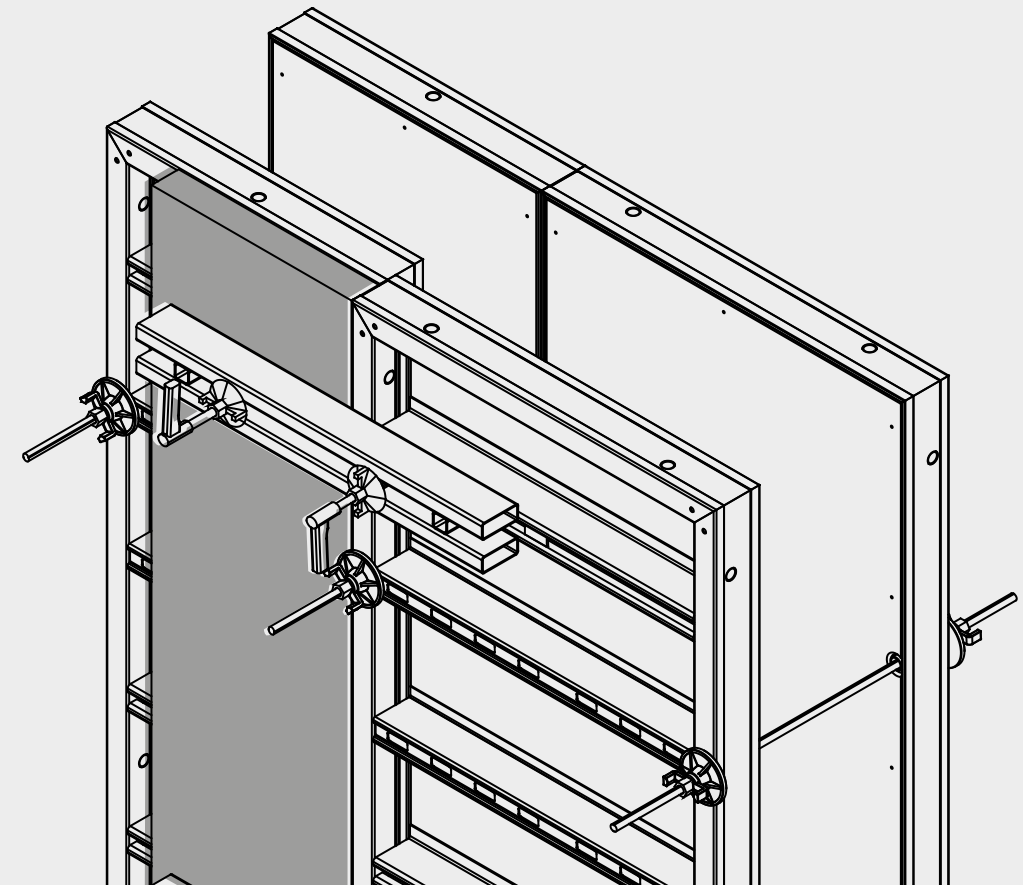

Example of formwork connection with different wall thickness.

CONNECTION WITH EXISTING WALL

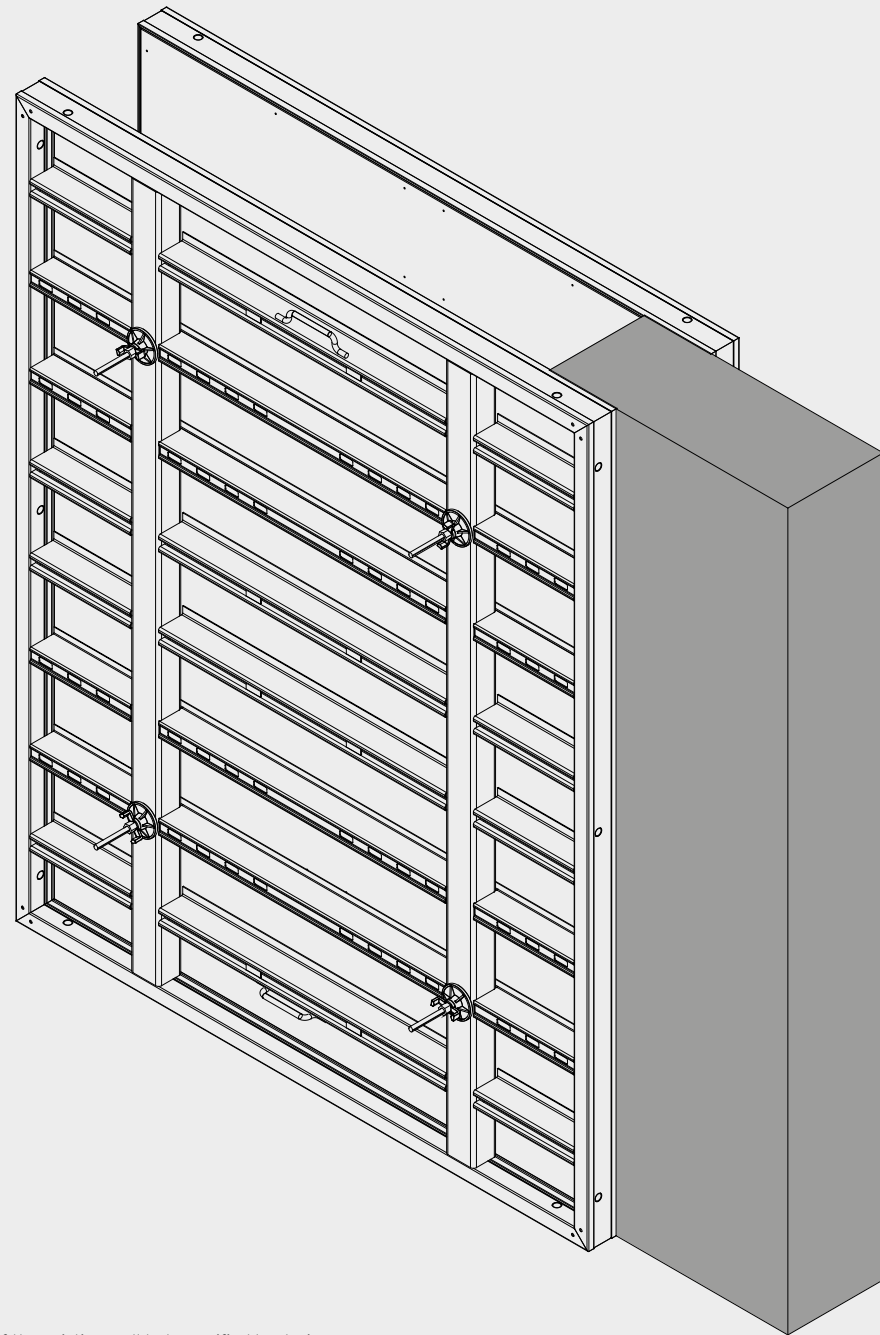

Overlapping distance of the existing wall to be verified by designer

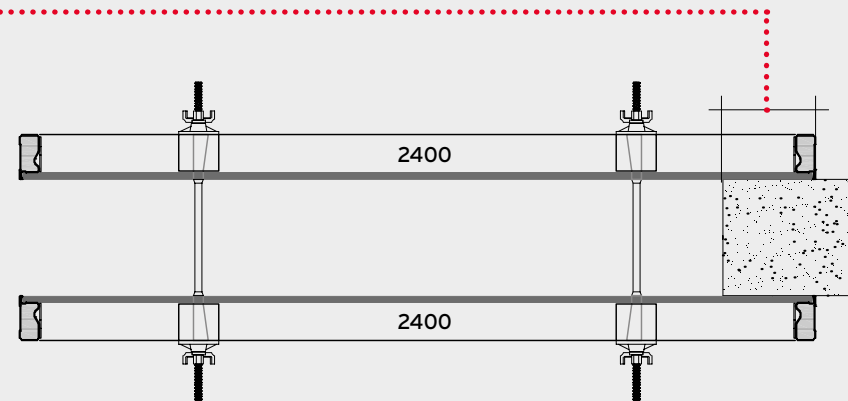

T-CONNECTION WITH EXISTING WALL

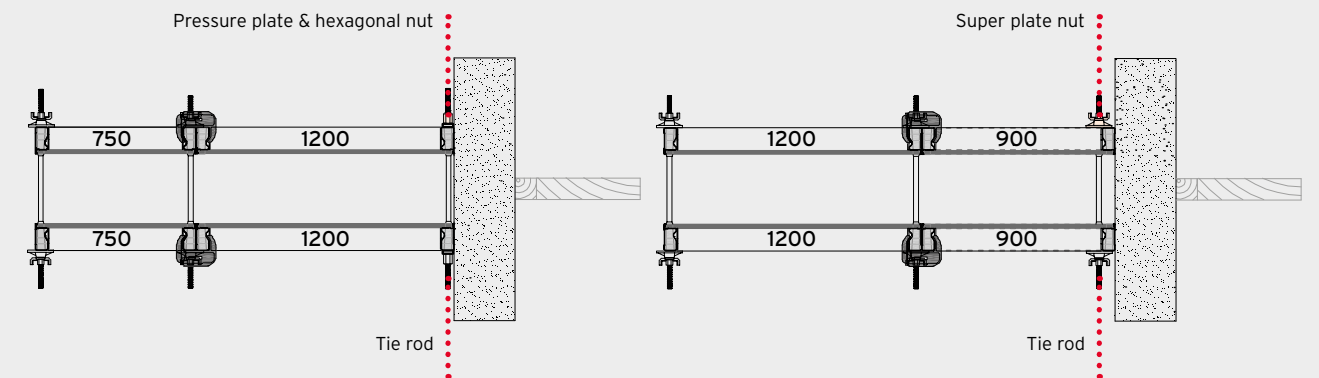
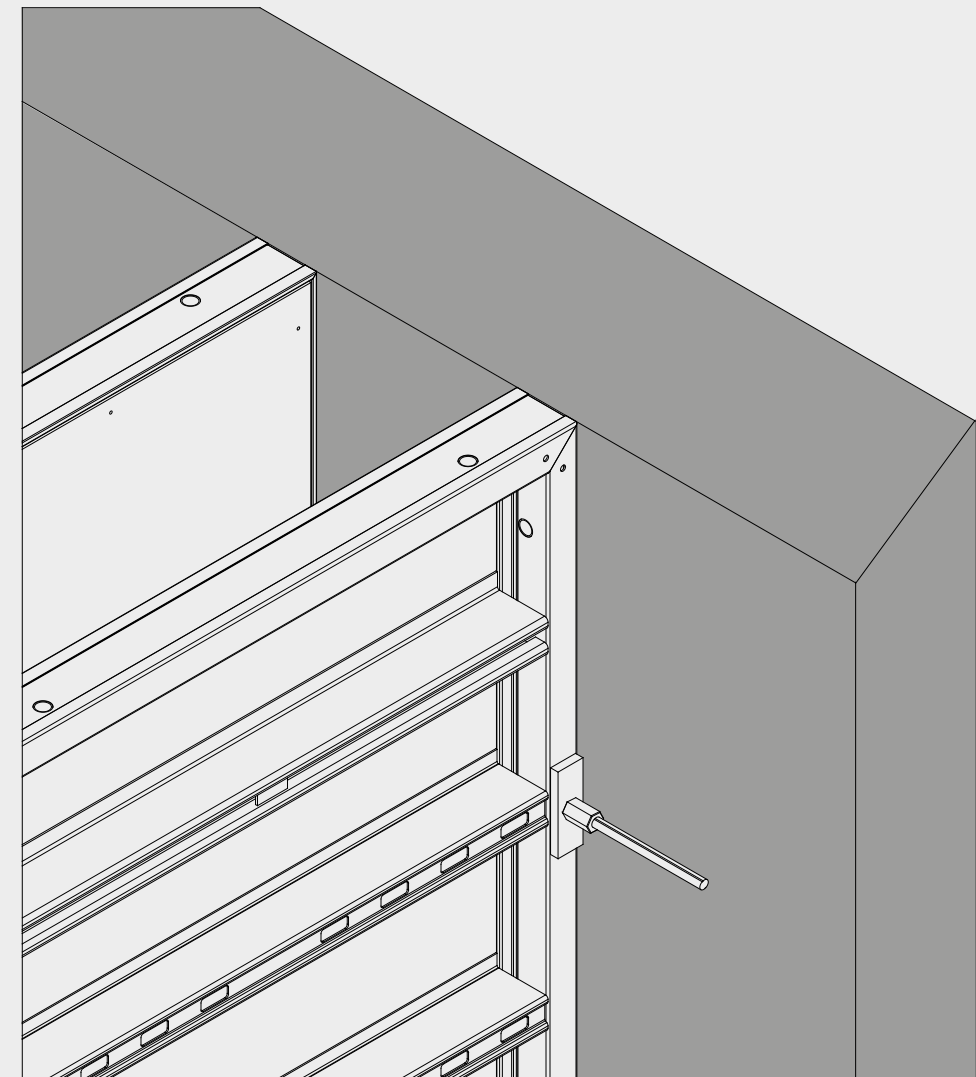



UNIVERSAL COLUMN FORMWORK

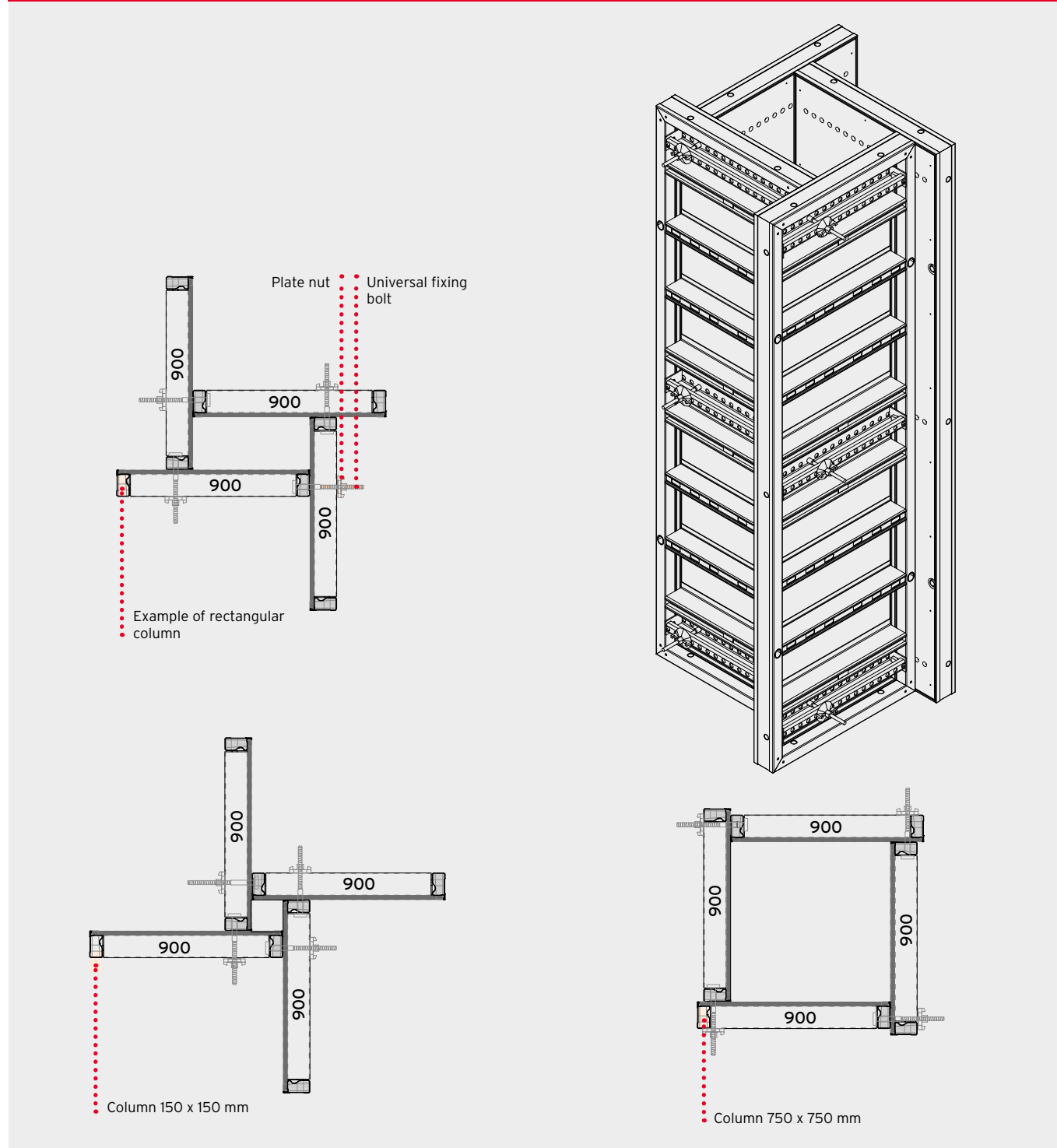

Even for universal framed panels for column formwork, Destil offers a wide range of possibilities. Universal elements are available in the following sizes:  
 In heights 3300/3000/2700/1800/1350 and 1200 mm  
 In widths 1350/1200 and 900 mm.  
 They permit constructing columns of different dimensions, from 150 x 150 mm up to 750 x 750 mm using 900 mm panels and up to 1050 x 1050 using 1200 mm panels. 1200 x 1200 mm, using 1350 mm panels for fixing and anchoring the formwork the universal fixing bolt and plate nut is used.

FIXING DETAILS

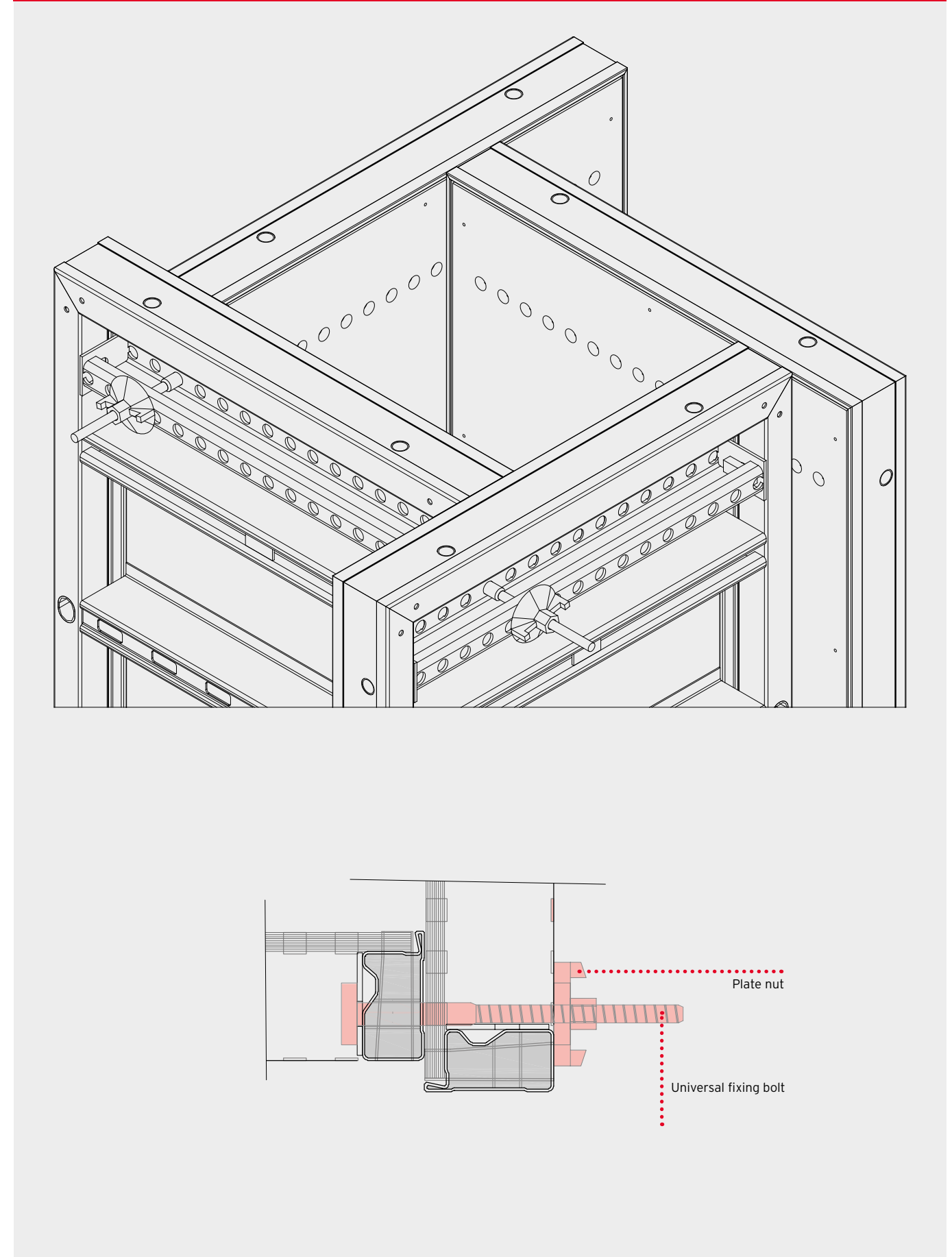



SHAFT REMOVING CORNER

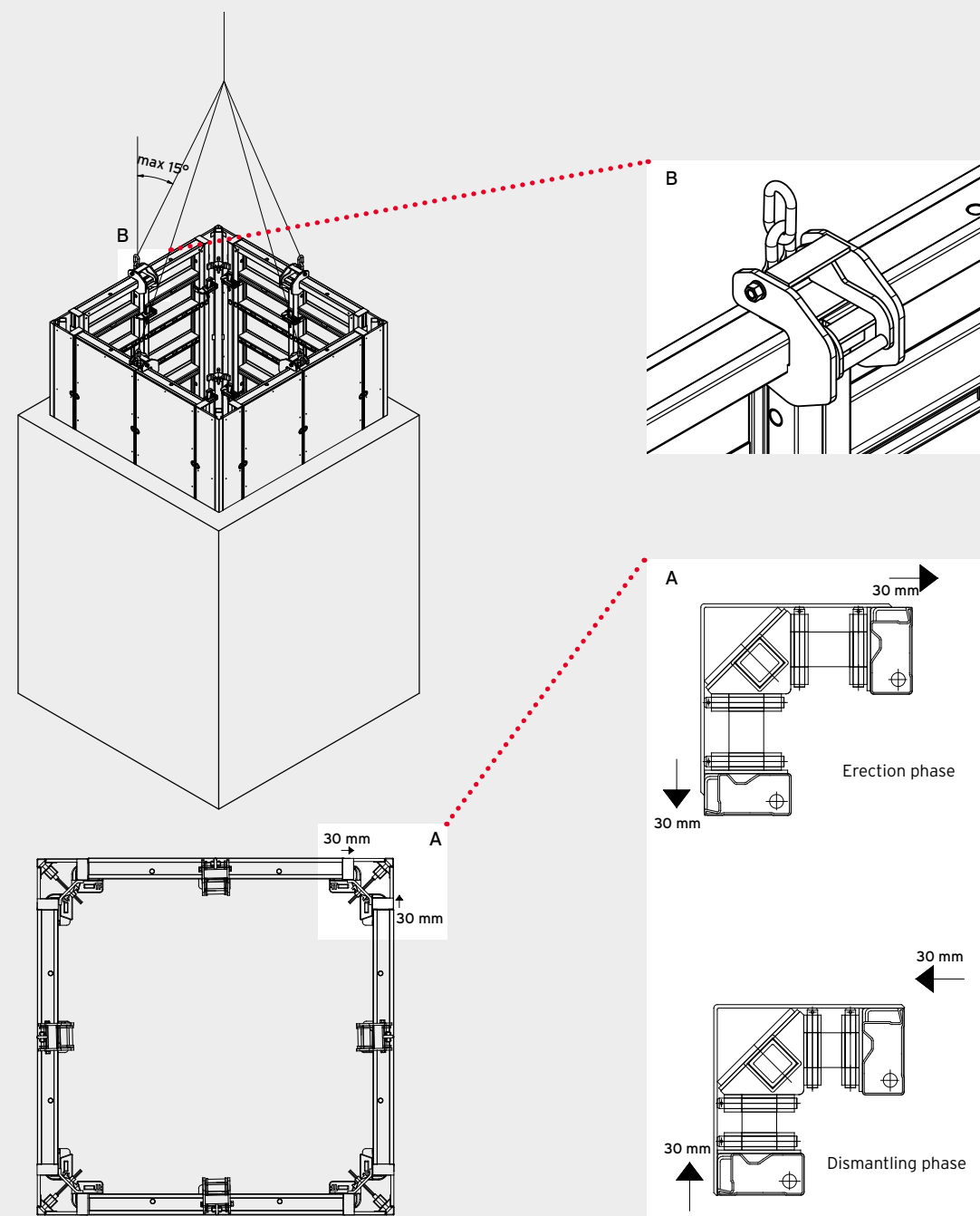

The inside stripping corner for shaft compartments can strip an entire inside formwork and shift it without having to dismantle any single element. Thanks to a special mechanism, the inner stripping corner allows the retraction of adjacent panels using a simple ratchet. After operating the retraction of the panels, the translation takes place in a simple, safe and quick action, with lifting hooks and a four-part lifting chain.

TRANSPORT AND STORAGE

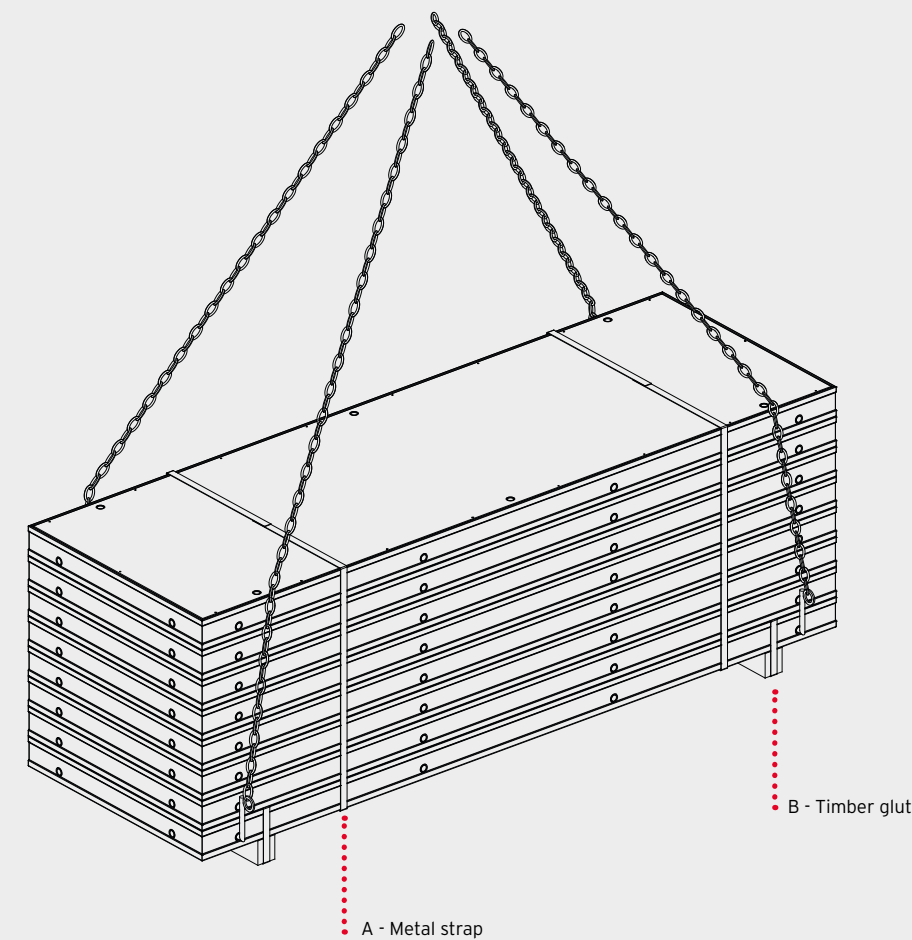

- 1) Place sleepers B 80x100 under the cross-profile
- 2) Strap the sleepers (hardwood blocking) and the bottom panel together with metal banding.
- 3) Stack up to 8 items.
- 4) Tie the stack of elements with the strapping A.

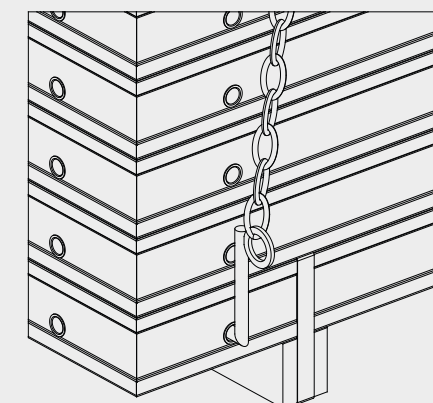

N.4 TRANSPORT PINS  
max CAPACITY 2000 kg (20 kN)

TRANSPORT AND STORAGE

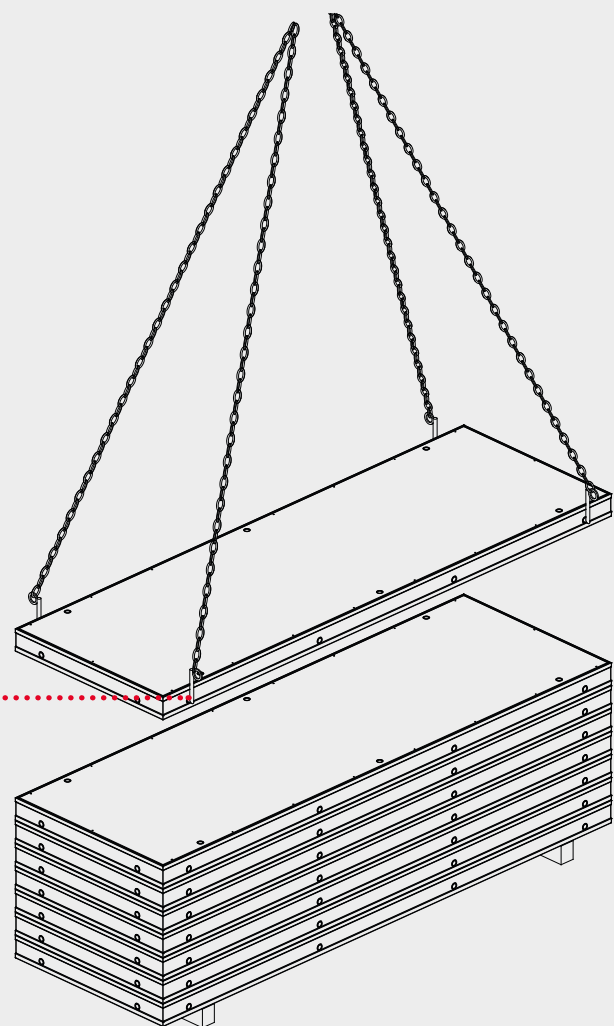

TRANSPORT PINS  
Max capacity 500 kg (5 kN)



Code: CC0000  
Weight: 2.00 Kg

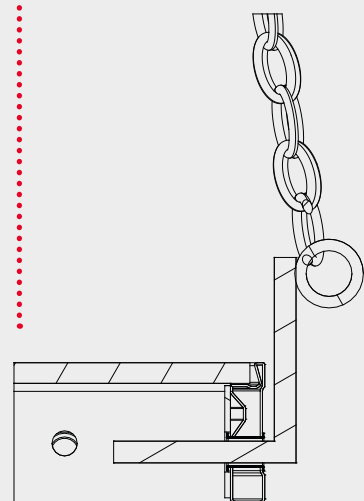

Transport pin (capacity 5 kN), used together with the four chain ropes, allowing the transport of single items or entire bundles.

LIFTING HOOK

Lifting hook must be placed on the border profile.

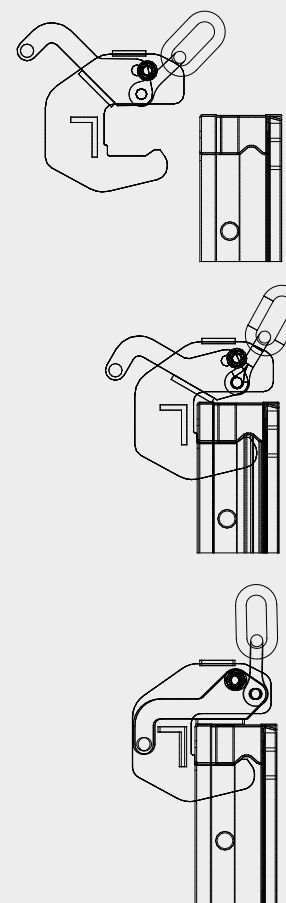
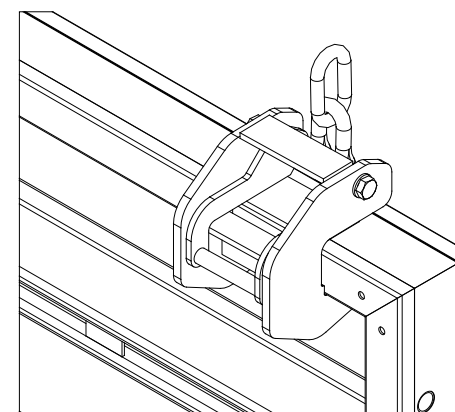

Lock up system with the lifting hook  
Lifting hook placement and lock-up sequence.

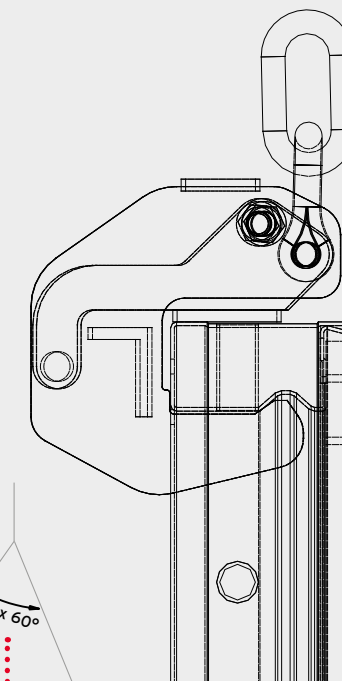

Ropes central, max angle 60°

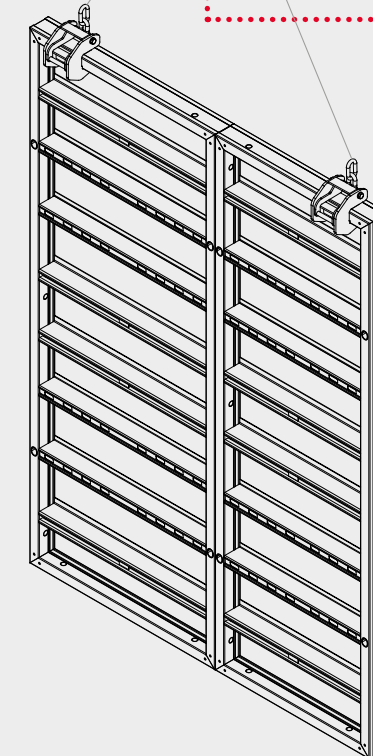

Code: CC0010 · Weight: 12.5 Kg

Used for lifting panels. Must be hooked-up with appropriate ropes which must not create an angle greater than 60°. Each lifting hook has an admissible load of 1500 Kg. The lock system to the border profile of the formwork is auto-lock up. The lifting hook should be placed near the frame stiffenings.

SUPER DESTIL : FORMWORK ELEMENTS

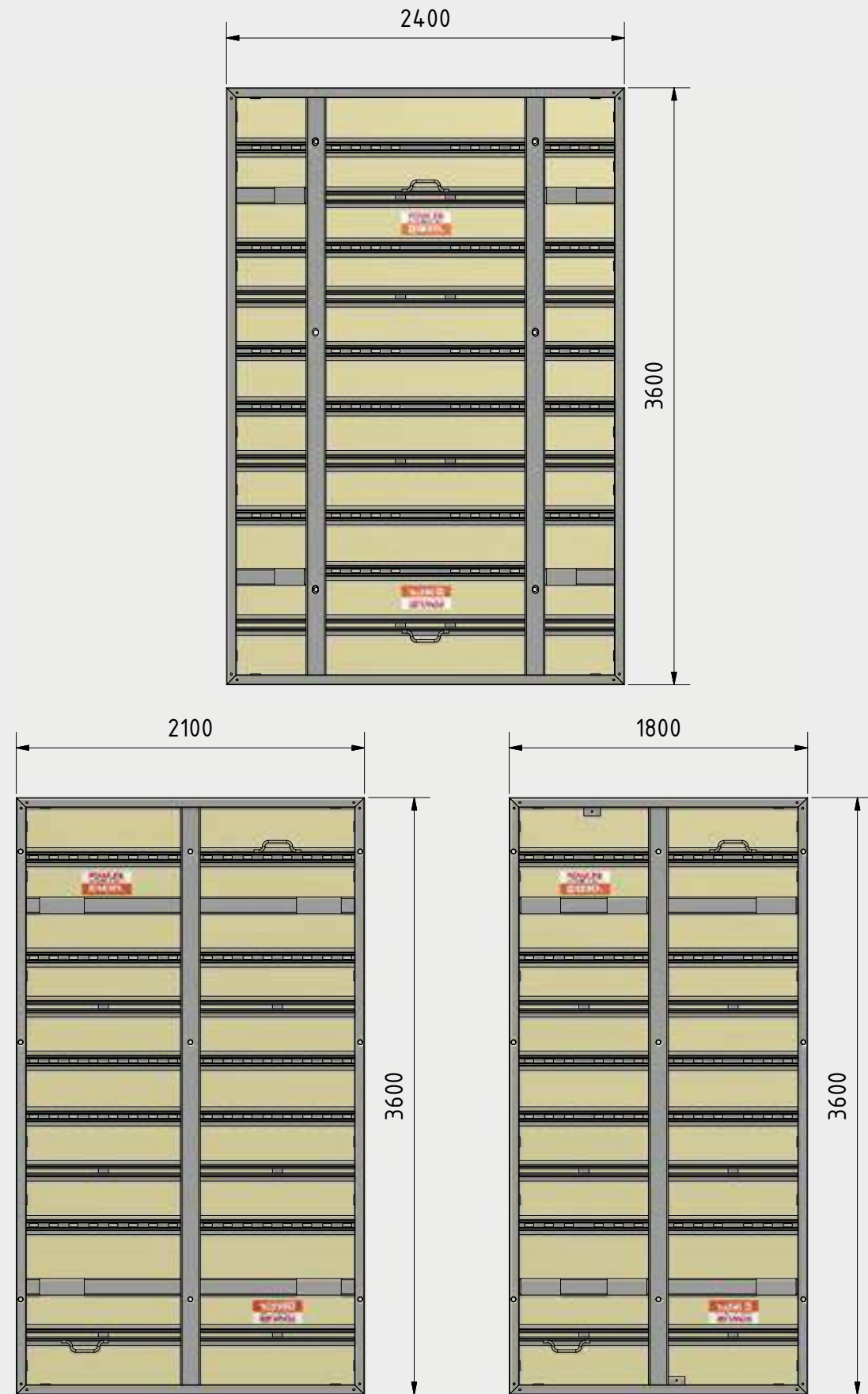

SUPER DESTIL : SLAB CONFIGURATION

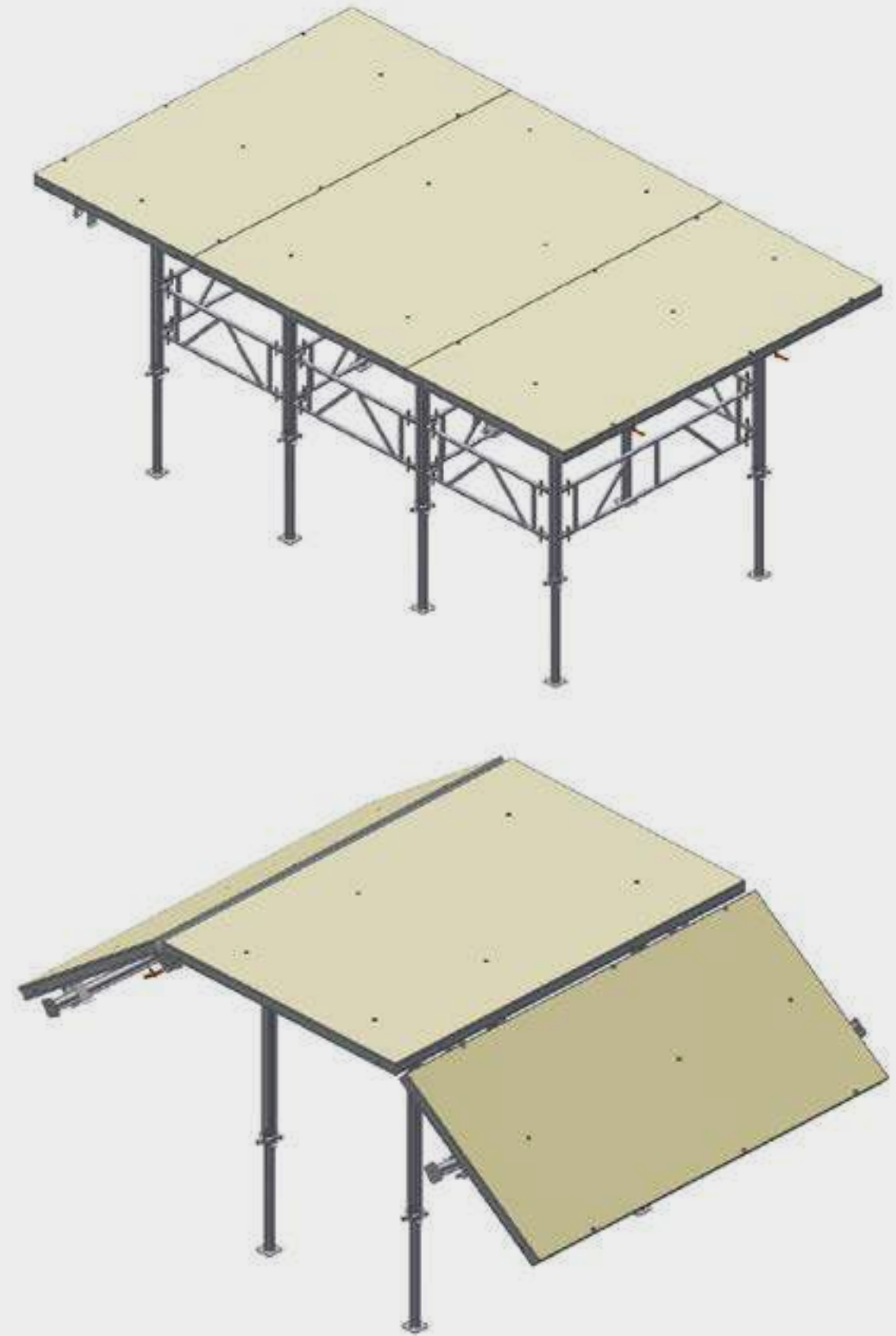

SUPER DESTIL : SLAB BASIC CONFIGURATIONS

L = 2400 X 3600

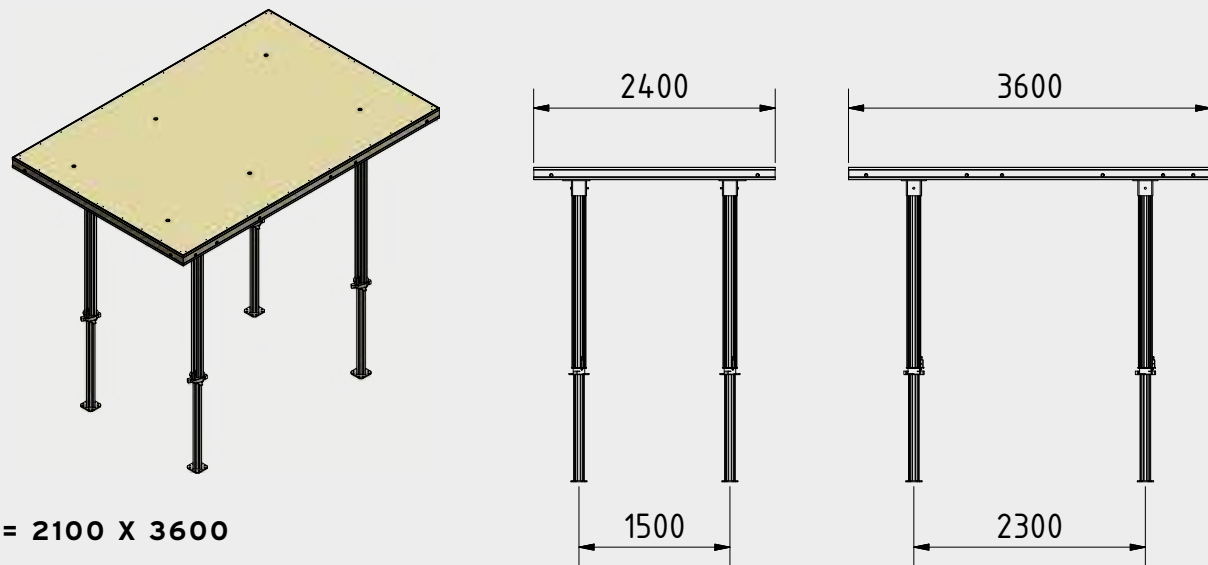

L = 2100 X 3600

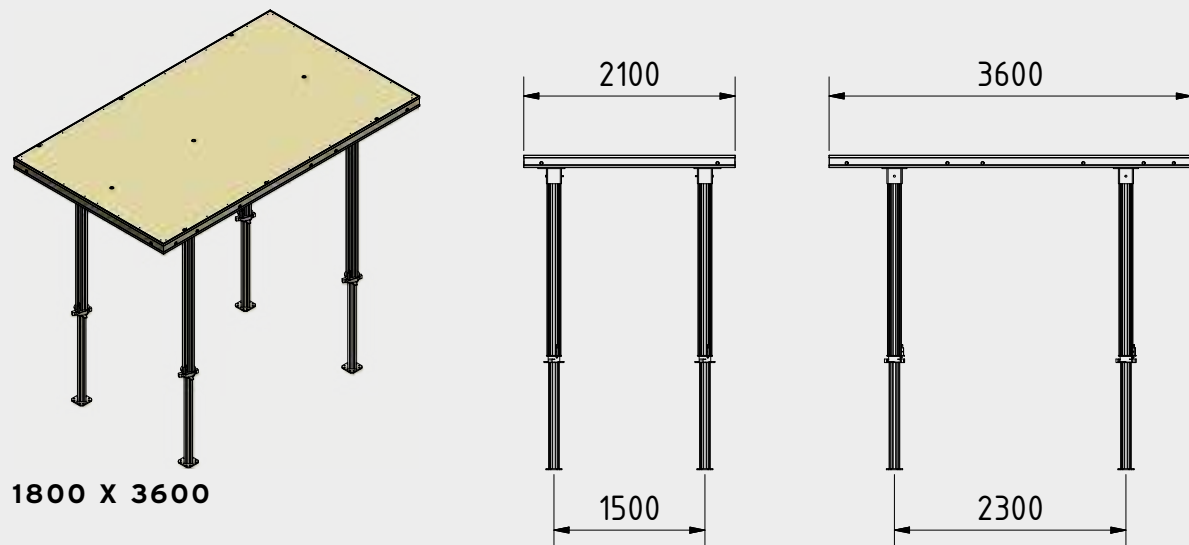

L = 1800 X 3600

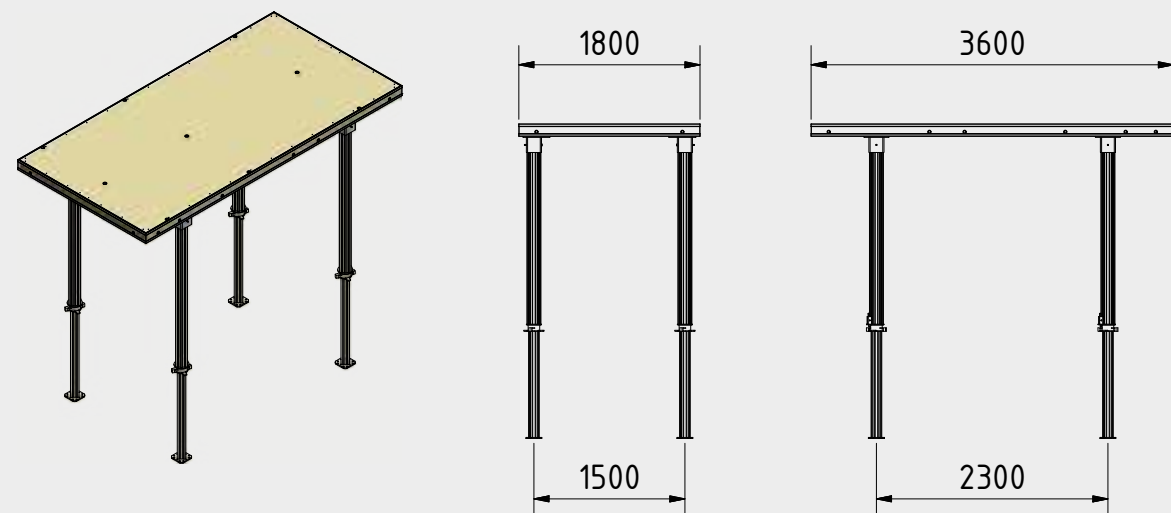

SUPER DESTIL : 6.0 m WING CONFIGURATION

L = (1800+2400+1800) X 3600 = 6000 X 3600

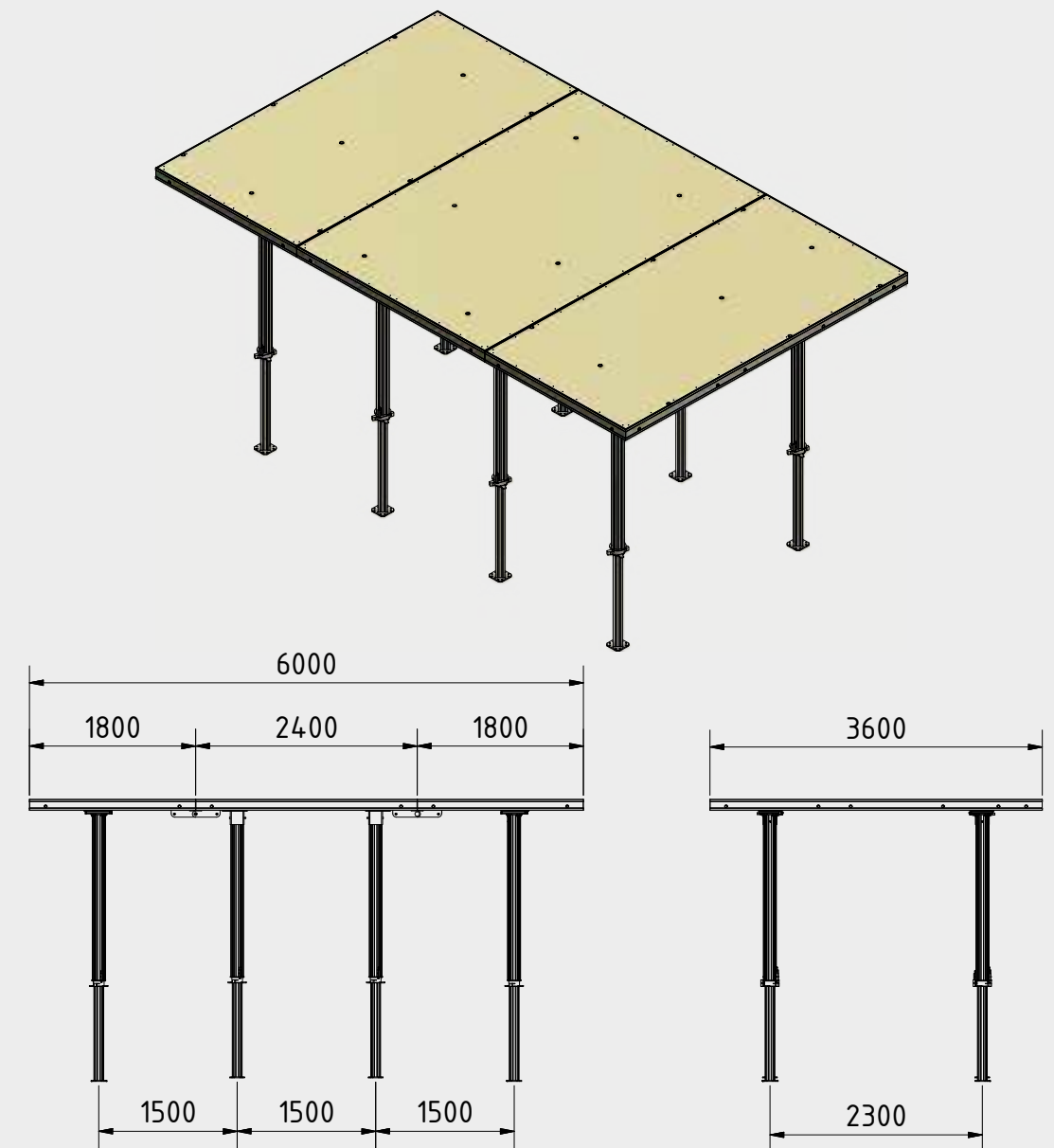

SUPER DESTIL : STRUCTURAL DESIGN

STANDARD CONFIGURATION	NUMBER OF PROPS	PRESSURE MAX (KN/M2)	MAX SLAB THICKNESS (MM)
2400 X 3600	4	50	2000
2100 X 3600	4	32	1300
1800 X 3600	4	32	1300
(1800+2400+1800) X 3600	8	28	1100

The max slab thickness referring to bearing capacity of SUPER DESTIL elements.  
LOADABILITY OF PROPS HAS TO BE CHECKED.



SUPER DESTIL - SLAB ACCESSORIES

**CONNECTION PLATE TYPE 1**

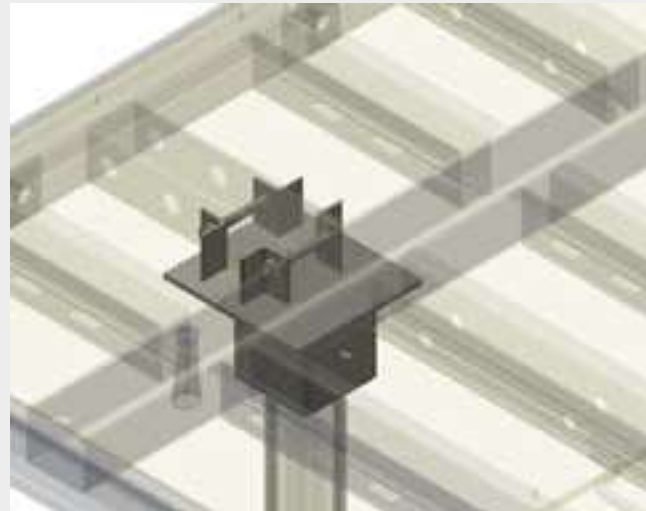
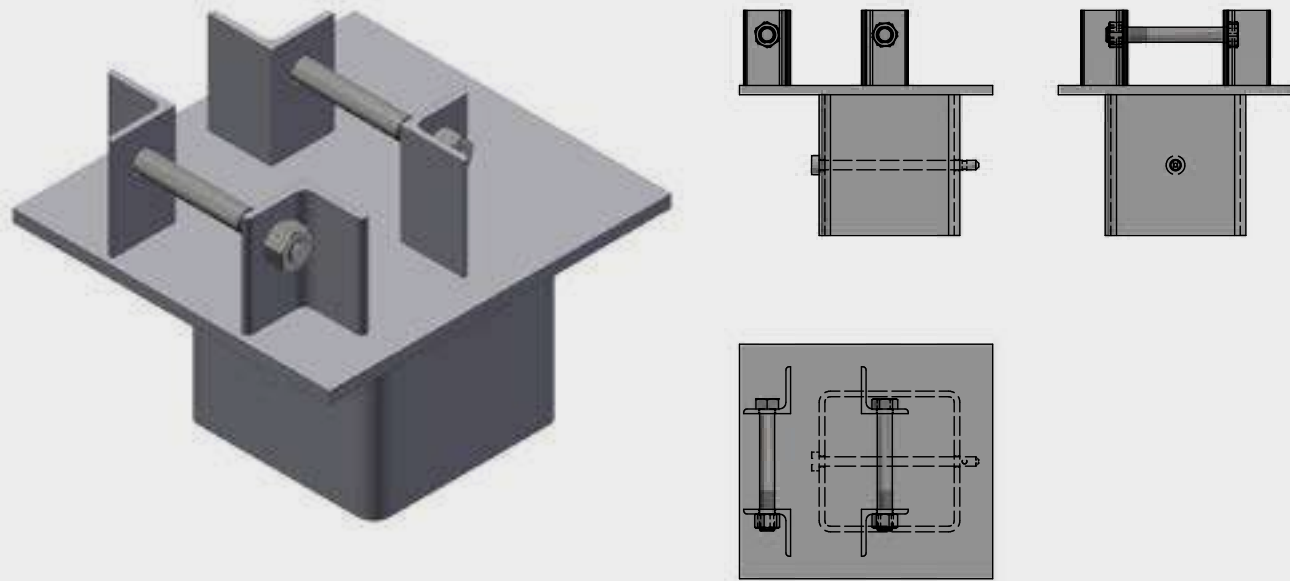

To be used in all single basic slab configurations and on the central 2400 element in wing configuration. It can be fixed to formwork panels by bolts or pins.

SUPER DESTIL - SLAB ACCESSORIES

**CONNECTION PLATE TYPE 2**

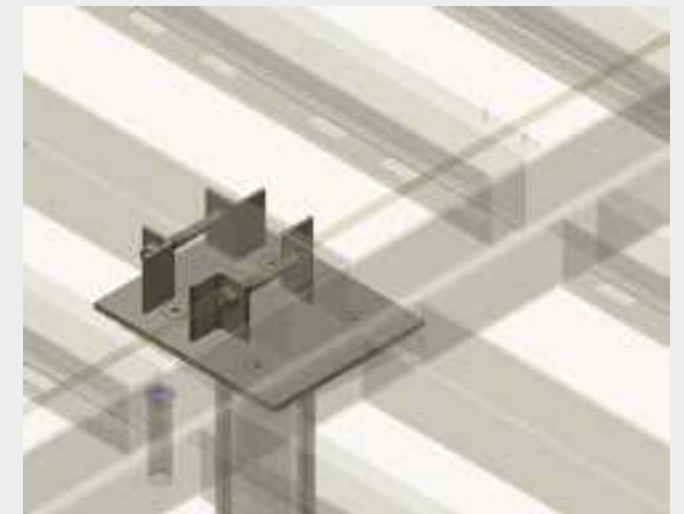
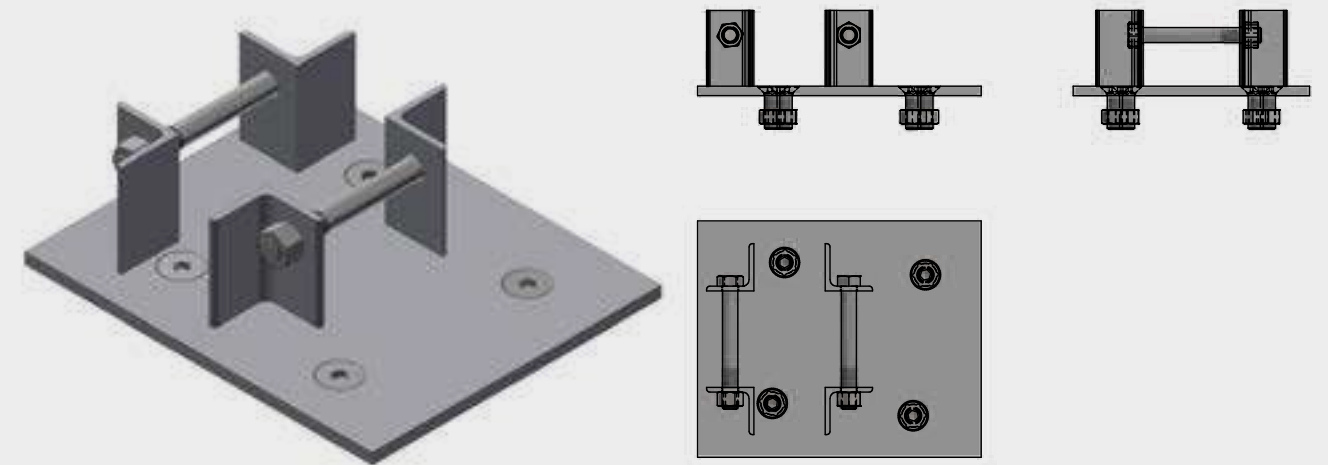

To be used for prop connection to lateral 1800 formwork elements, in wing configuration, and in combination with "Prop bracket-wing panel". It can be fixed to formwork panels by bolts or pins.

SUPER DESTIL - SLAB ACCESSORIES

**PROP BRACKET-WING PANEL**

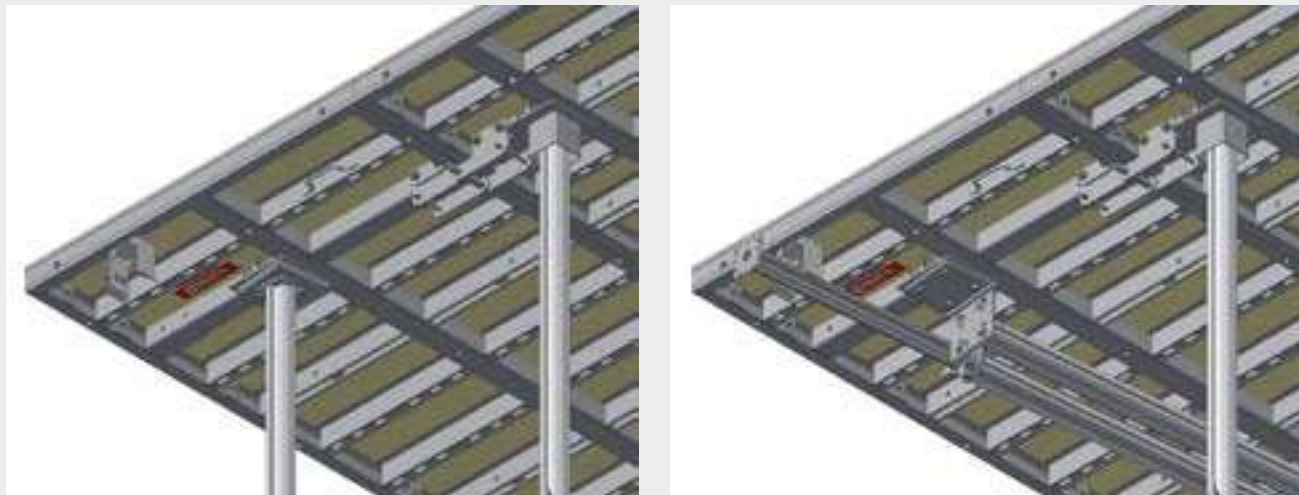
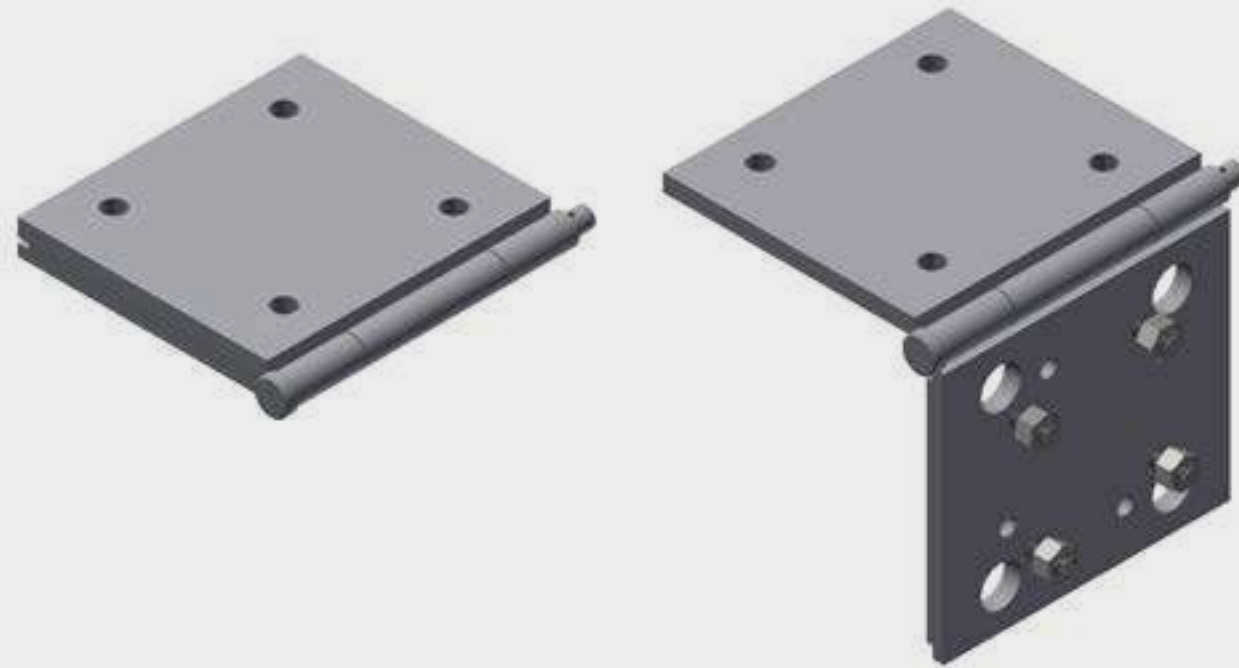

To be used for prop connection to lateral 1800 formwork elements, in wing configuration, and in combination with "Connection plate type 2" to which is bolted.

SUPER DESTIL - SLAB ACCESSORIES

**FORMWORK TABLE HINGE**

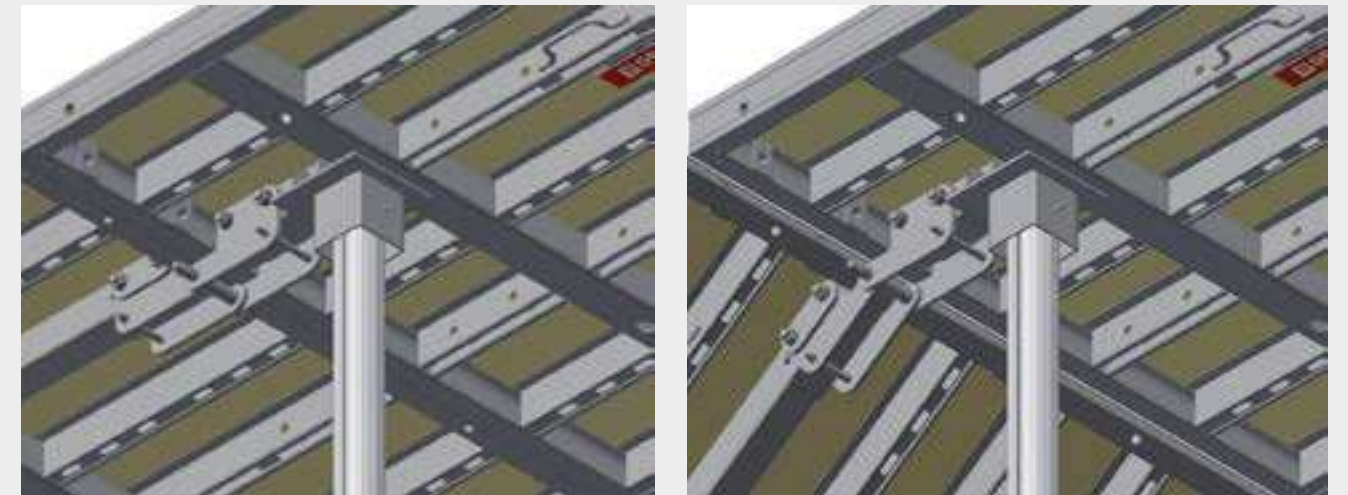
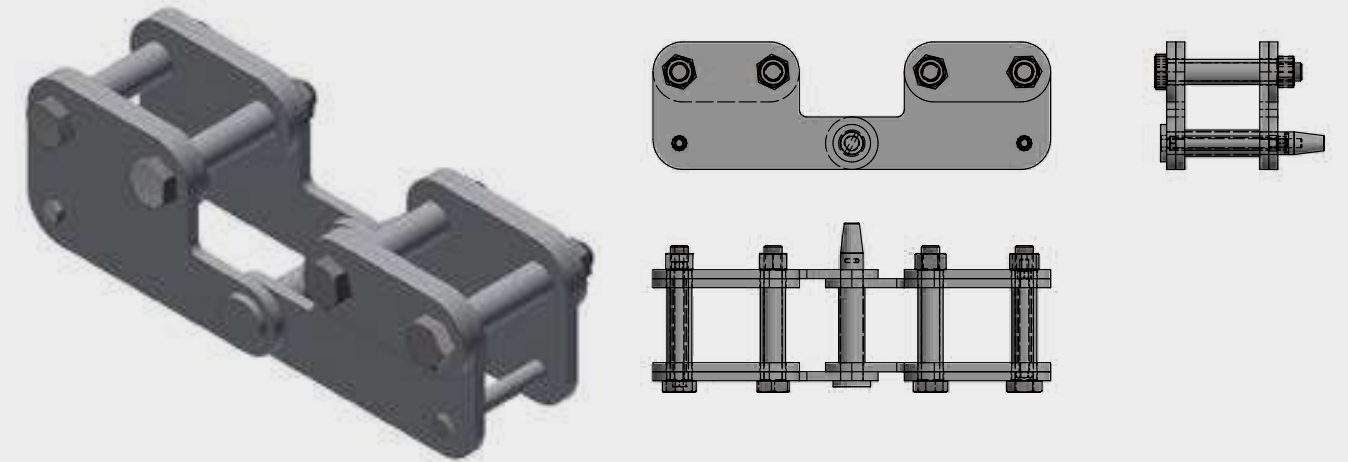

To be used to connect and to allow rotation between laterals (1800) and central (2400) formwork elements in wing configuration.



SUPER DESTIL - SLAB ACCESSORIES

**SUPER DESTIL PARAPET - USE IN SLAB CONFIGURATION**

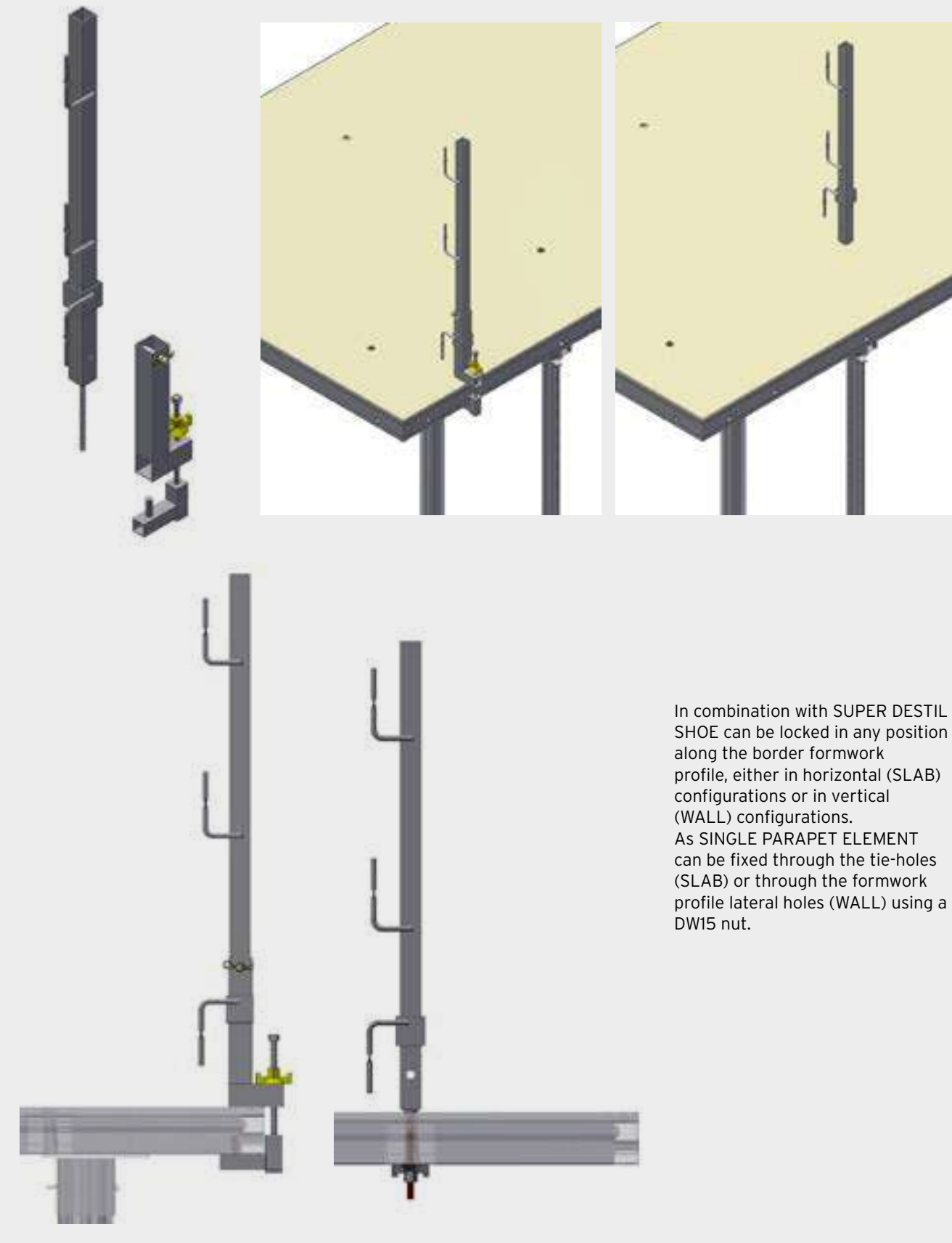

In combination with SUPER DESTIL SHOE can be locked in any position along the border formwork profile, either in horizontal (SLAB) configurations or in vertical (WALL) configurations. As SINGLE PARAPET ELEMENT can be fixed through the tie-holes (SLAB) or through the formwork profile lateral holes (WALL) using a DW15 nut.

SUPER DESTIL - SLAB ACCESSORIES

**INFILL BRACKET**

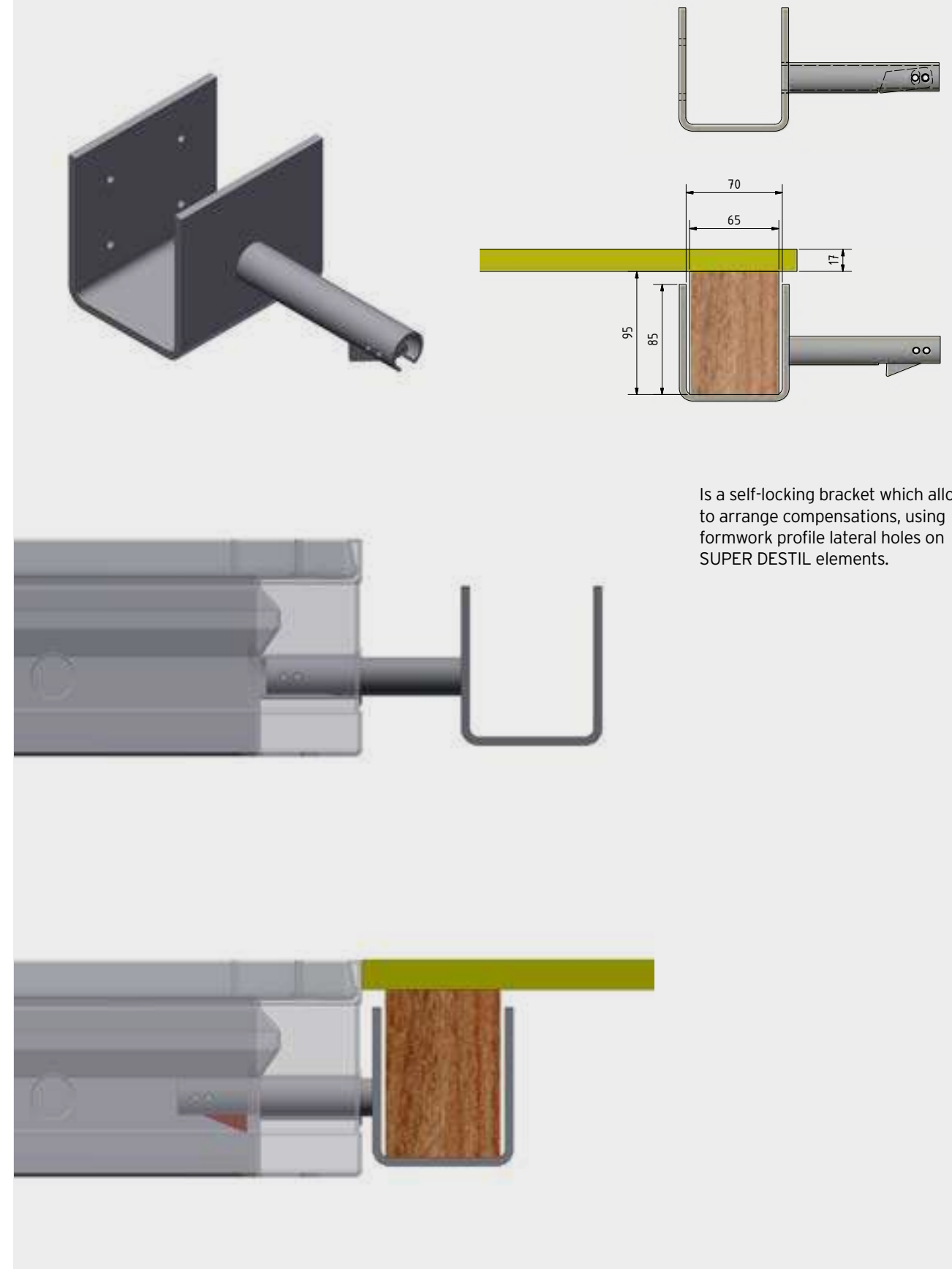

Is a self-locking bracket which allows to arrange compensations, using formwork profile lateral holes on SUPER DESTIL elements.

SUPER DESTIL - SLAB ACCESSORIES

**INFILL BRACKET**

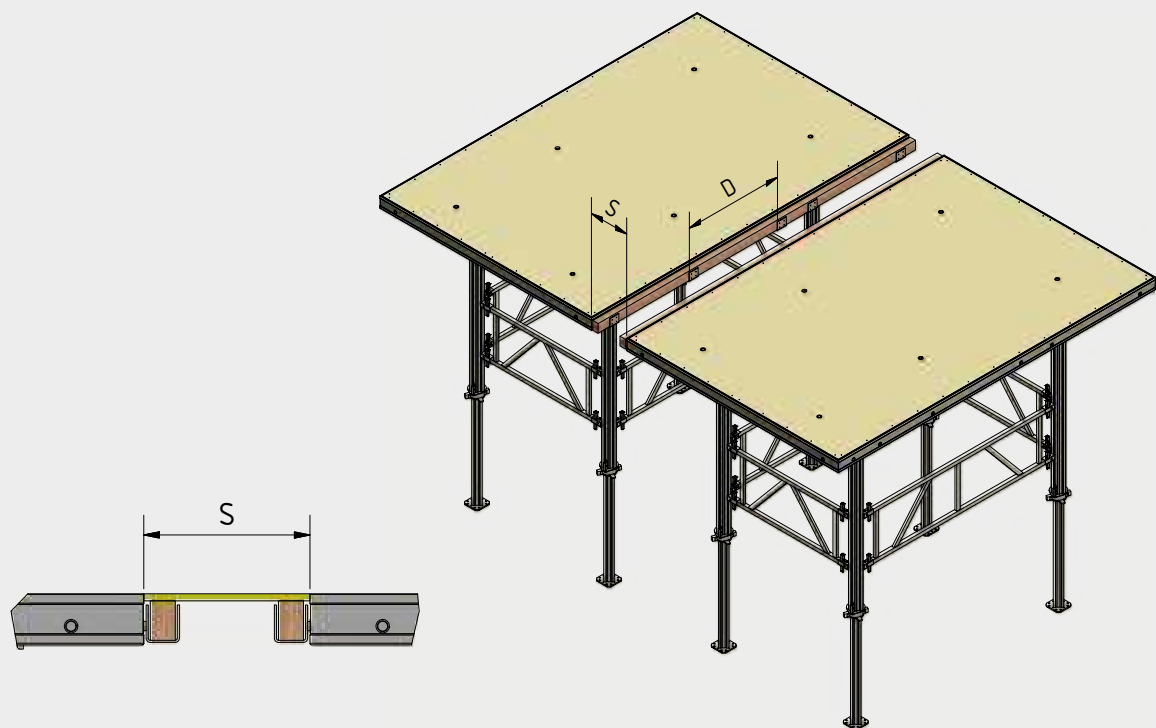

CLOSURE WIDTH ( S )	MAX SPACING BETWEEN 2 INFILL BRACKET ( D )	MAX PERMITTED SLAB THICKNESS
300 mm	1000 mm	800 mm
400 mm	1000 mm	700 mm
500 mm	1000 mm	550 mm
600 mm	1000 mm	400 mm
700 mm	1000 mm	350 mm

THE INDICATED MAX PERMITTED SLAB THICKNESS IS REFERRED TO THE BEARING CAPACITY OF THE INFILL BRACKET ONLY. WOOD PARTS HAS TO BE CHECKED BY SITE.

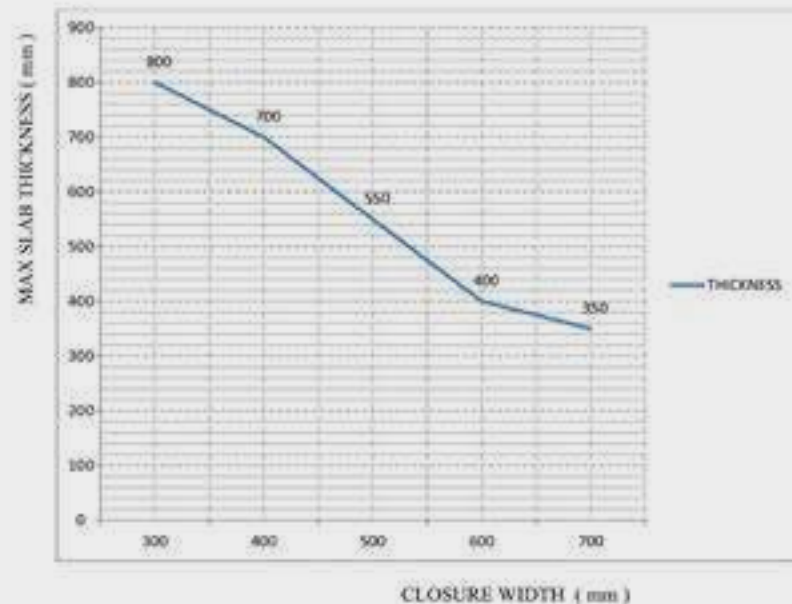

SUPER DESTIL - SLAB ACCESSORIES

**PROP LOCKING BRACKET**

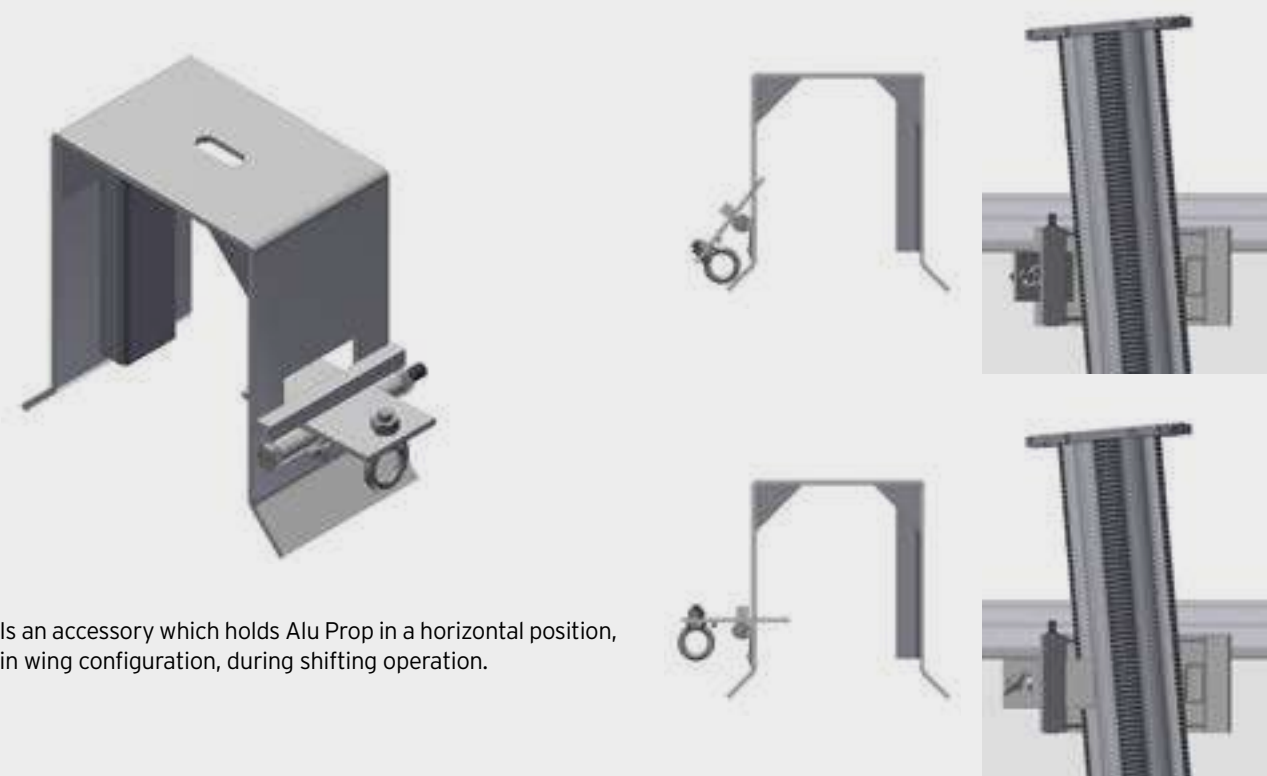

Is an accessory which holds Alu Prop in a horizontal position, in wing configuration, during shifting operation.





SUPER DESTIL - SLAB ACCESSORIES

**WING CATCHING BRACKET**

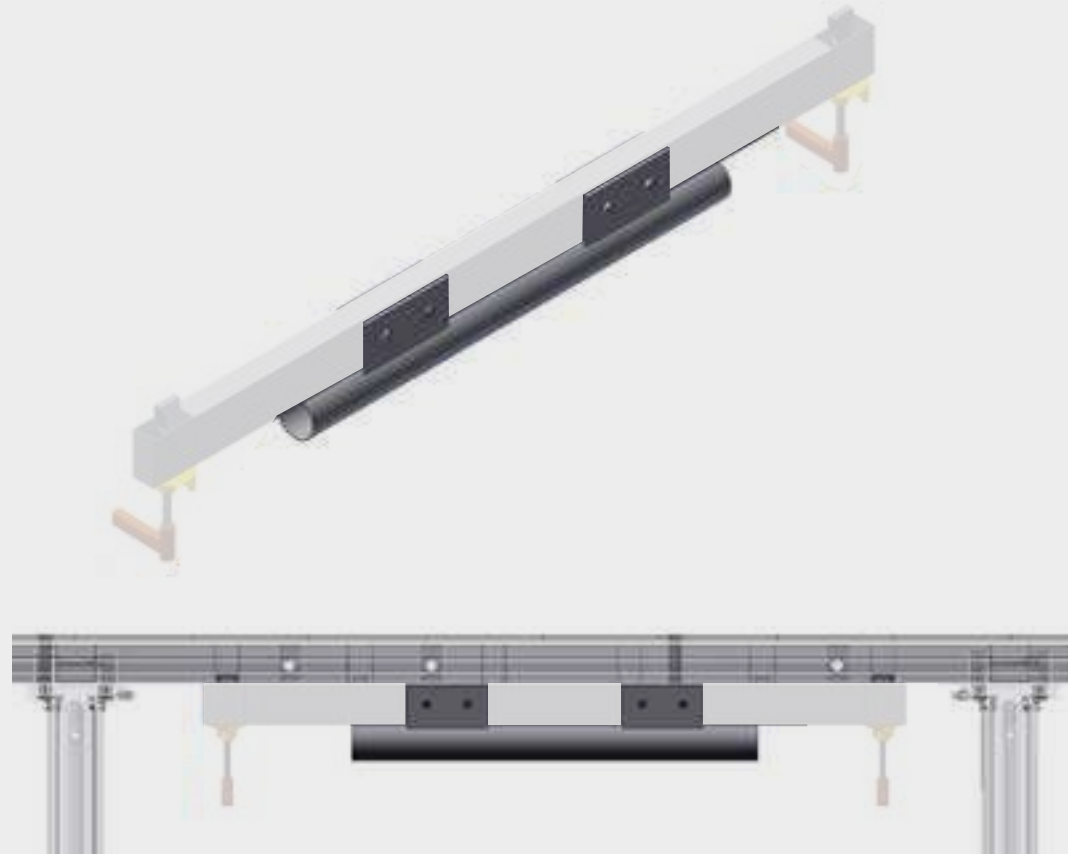

Accessory to be connected to lateral formwork in wing configuration, to allow formwork easy rotation during stripping phase.

SUPER DESTIL - SLAB ACCESSORIES

**HORIZONTAL REPOSITIONING / TRAVELLING**



Super Destil formwork is hydraulically lifted, lowered and horizontal repositioned through the use of a standard handling unit combined with an applied special metal frame. The lifting appliance is operated by just one man with a spotter, allows formwork to be moved in a safe and fast process.



ITEMS LIST

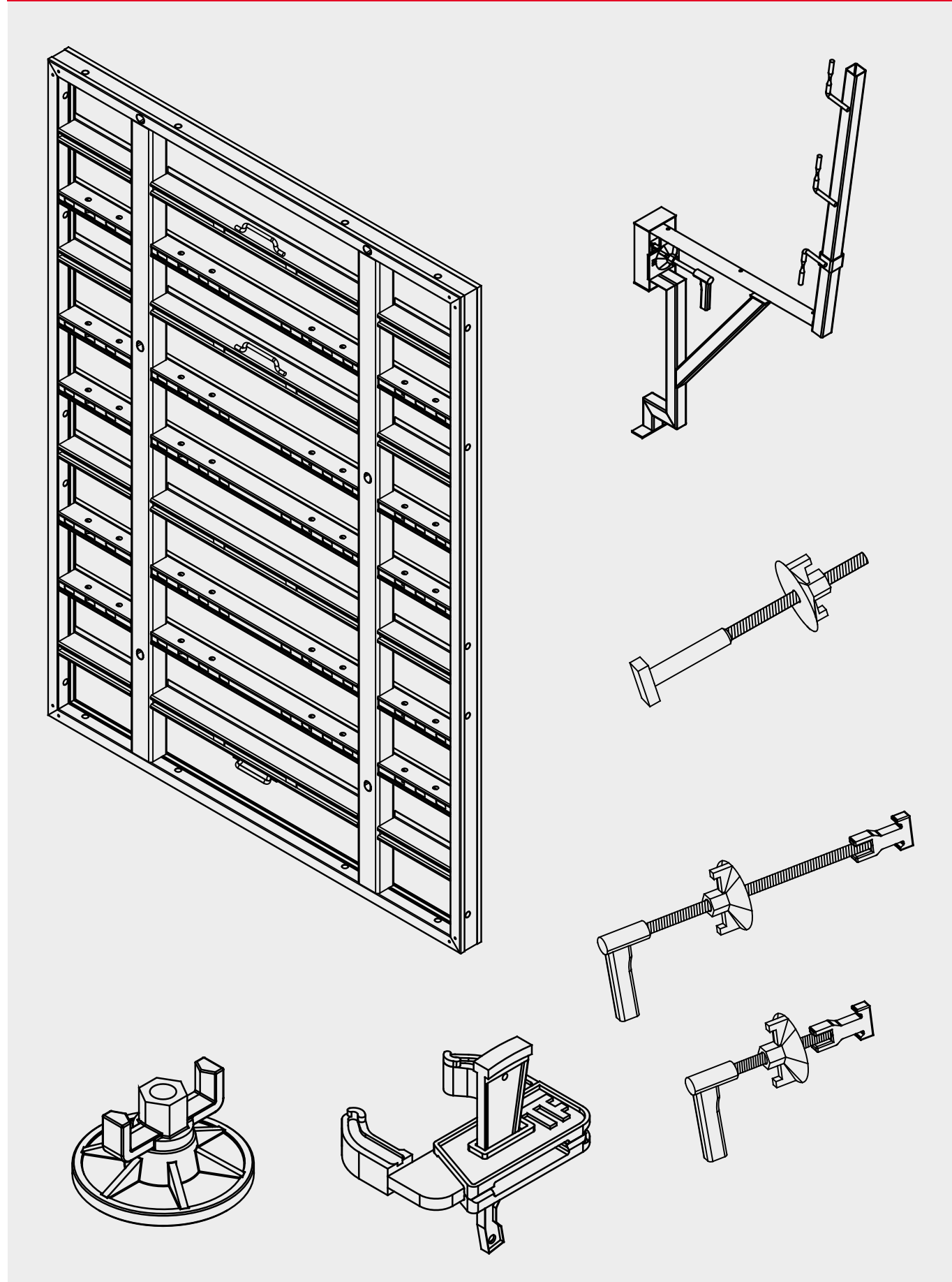

**DESTIL 3300**  
FORMWORK

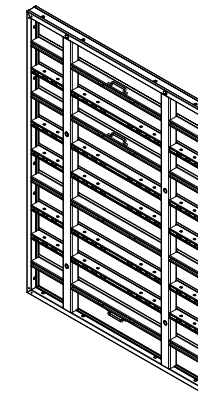

CODE	DESCRIPTION	WEIGHT (KG)
330240	3300 x 2400	422.10

**DESTIL 3300**  
FORMWORK

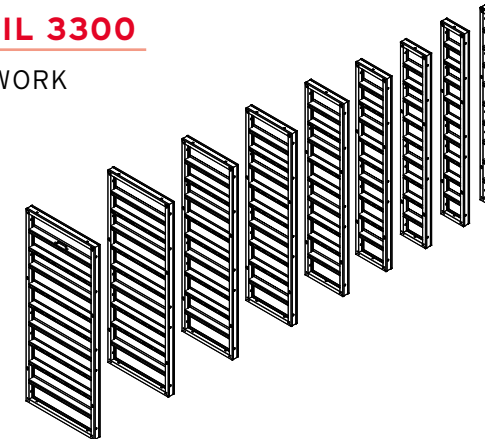

CODE	DESCRIPTION	WEIGHT (KG)
330135	3300 x 1350	227.70
330120	3300 x 1200	190.00
330100	3300 x 1000	167.20
330090	3300 x 900	151.90
330075	3300 x 750	137.70
330060	3300 x 600	123.80
330050	3300 x 500	107.00
330045	3300 x 450	98.50
330030	3300 x 300	80.50

**DESTIL 3300**  
UNIVERSAL FORMWORK

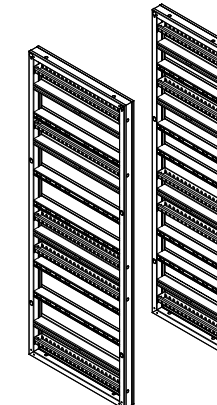

CODE	DESCRIPTION	WEIGHT (KG)
33135U	3300 x 1350 UNIV.	263.00
33012U	3300 x 1200 UNIV.	234.00
33009U	3300 x 900 UNIV.	188.10

**DESTIL 3300**  
CORNERS

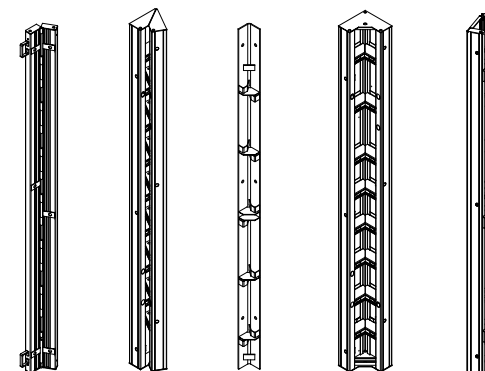

CODE	DESCRIPTION	WEIGHT (KG)
AIF330	Inside fixed corner	116.50
AEF330	Outside fixed corner	55.00
AIC330	Hinged inside corner	142.20
AEC330	Hinged outside corner	78.00
ADR330	Shaft removing corner	215.00



**DESTIL 3000**  
FORMWORK

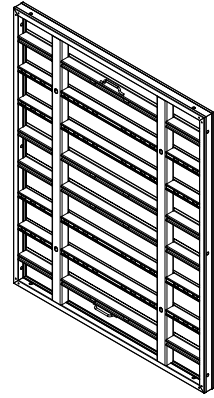

CODE	DESCRIPTION	WEIGHT (KG)
330240	3000 x 2400	384.10

**DESTIL 3000**  
FORMWORK

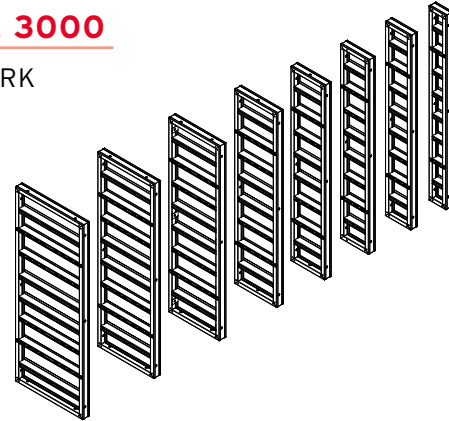

CODE	DESCRIPTION	WEIGHT (KG)
300135	3000 x 1350	198.50
330120	3000 x 1200	172.10
330100	3000 x 1000	150.50
300090	3000 x 900	139.00
300075	3000 x 750	122.60
300060	3000 x 600	105.80
300050	3000 x 500	94.90
300045	3000 x 450	89.30
300030	3000 x 300	72.80

**DESTIL 3000**  
UNIVERSAL FORMWORK

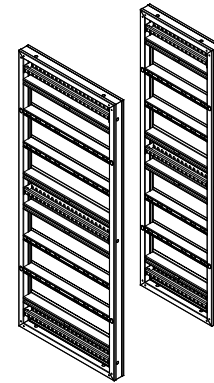

CODE	DESCRIPTION	WEIGHT (KG)
300135U	3000 x 1350 UNIV.	239.00
30012U	3000 x 1200 UNIV.	197.00
30009U	3000 x 900 UNIV.	160.70

**DESTIL 3000**  
CORNERS

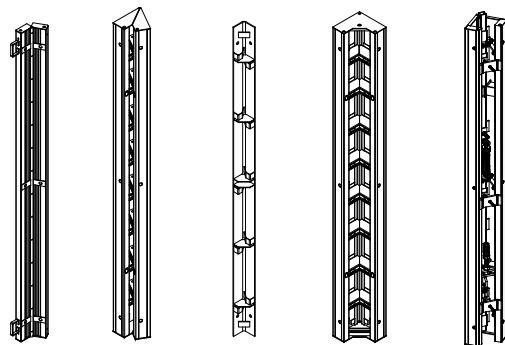

CODE	DESCRIPTION	WEIGHT (KG)
AIF300	Inside fixed corner	104.90
AEF300	Outside fixed corner	48.00
AIC300	Hinged inside corner	132.00
AEC300	Hinged outside corner	70.00
ADR300	Shaft removing corner	192.00

**DESTIL 2700**  
FORMWORK

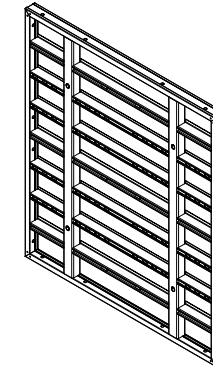

CODE	DESCRIPTION	WEIGHT (KG)
270240	2700 x 2400	344.40

**DESTIL 2700**  
FORMWORK

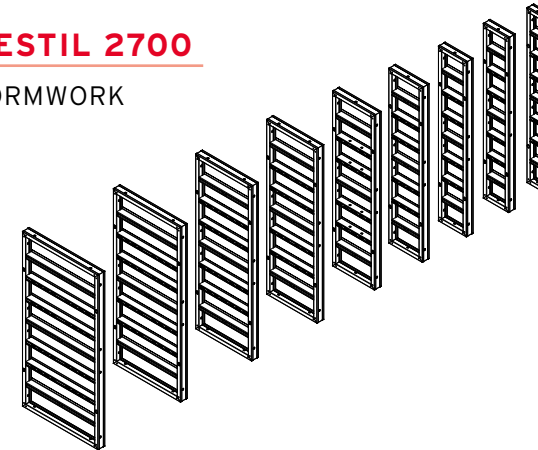

CODE	DESCRIPTION	WEIGHT (KG)
270135	2700 x 1350	169.3
270120	2700 x 1200	154.60
270100	2700 x 1000	141.10
270090	2700 x 900	126.70
270075	2700 x 750	110.40
270060	2700 x 600	95.40
270050	2700 x 500	85.70
270045	2700 x 450	80.70
270030	2700 x 300	68.70

**DESTIL 2700**  
UNIVERSAL FORMWORK

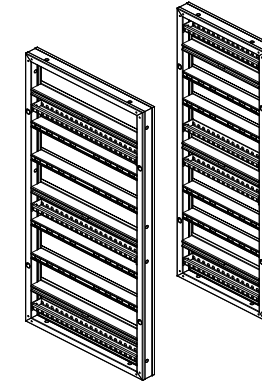

CODE	DESCRIPTION	WEIGHT (KG)
270135U	2700 x 1350 UNIV.	230.00
27012U	2700 x 1200 UNIV.	203.20
27009U	2700 x 900 UNIV.	154.00

**DESTIL 2700**  
CORNERS

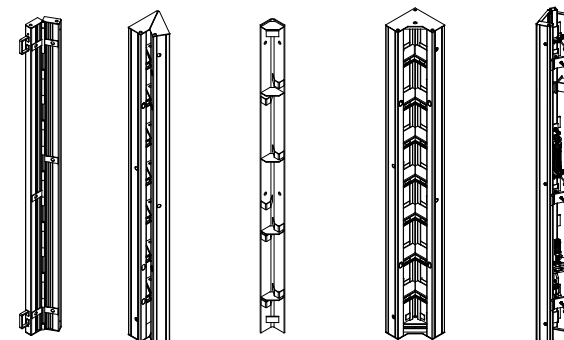

CODE	DESCRIPTION	WEIGHT (KG)
AIF270	Inside fixed corner	94.40
AEF270	Outside fixed corner	408.00
AIC270	Hinged inside corner	118.70
AEC270	Hinged outside corner	62.90
ADR270	Shaft removing corner	172.80

**DESTIL 1350**

FORMWORK

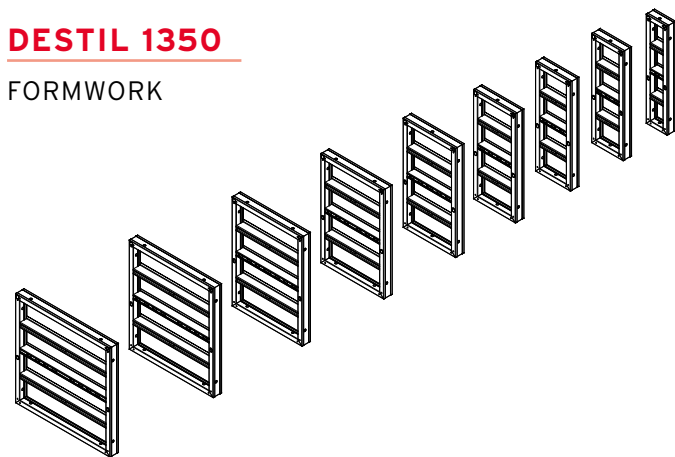

CODE	DESCRIPTION	WEIGHT (KG)
135135	1350 x 1350	91.90
135120	1350 x 1200	83.80
135100	1350 x 1000	75.30
135090	1350 x 900	67.80
135075	1350 x 750	57.30
135060	1350 x 600	51.30
135050	1350 x 500	48.20
135045	1350 x 450	43.40
135030	1350 x 300	35.40

**DESTIL 1350**

UNIVERSAL FORMWORK

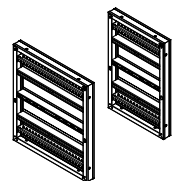

CODE	DESCRIPTION	WEIGHT (KG)
135135U	1350 x 1350 UNIV.	99.00
135120U	1350 x 1200 UNIV.	93.00
135090U	1350 x 900 UNIV.	82.10

**DESTIL 1350**

CORNERS

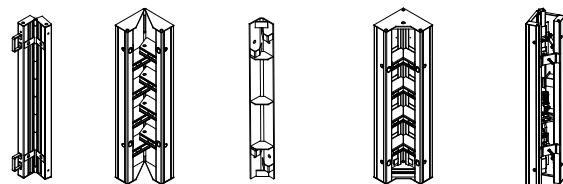

CODE	DESCRIPTION	WEIGHT (KG)
AIF135	Inside fixed corner	56.60
AEF135	Outside fixed corner	23.20
AIC135	Hinged inside corner	64.40
AEC135	Hinged outside corner	32.40
ADR135	Shaft removing corner	86.40

**DESTIL 1200**

FORMWORK

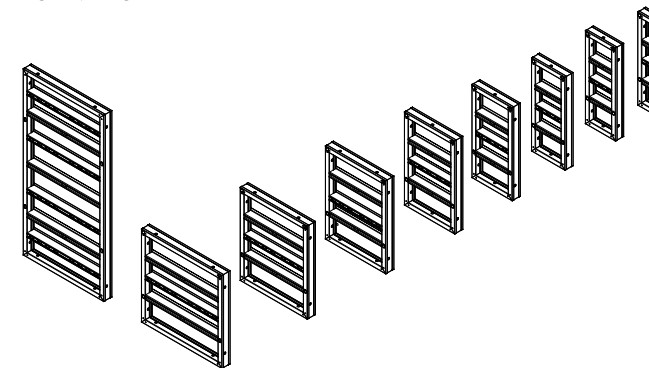

CODE	DESCRIPTION	WEIGHT (KG)
120240	1200 x 2400	145.20
120120	1200 x 1200	79.60
120100	1200 x 1000	69.30
120090	1200 x 900	63.10
120075	1200 x 750	56.20
120060	1200 x 600	48.20
120050	1200 x 500	43.50
120045	1200 x 450	40.40
120030	1200 x 300	32.60

**DESTIL 1200**

UNIVERSAL FORMWORK

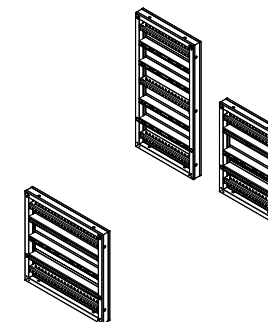

CODE	DESCRIPTION	WEIGHT (KG)
18135U	1200 x 1350 UNIV.	104.00
120120U	1200 x 1200 UNIV.	98.00
120090U	1200 x 900 UNIV.	77.70

**DESTIL 1200**

CORNERS

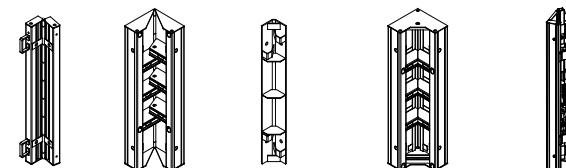

CODE	DESCRIPTION	WEIGHT (KG)
AIF120	Inside fixed corner	52.00
AEF120	Outside fixed corner	20.70
AIC120	Hinged inside corner	53.00
AEC120	Hinged outside corner	28.90
ADR120	Shaft removing corner	76.80

**SUPER DESTIL 3600 X 2400**

FORMWORK

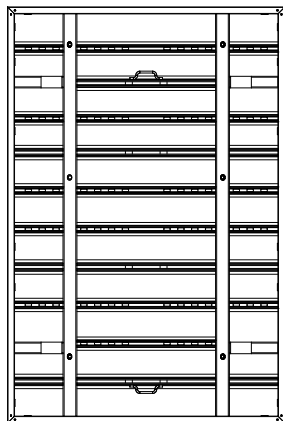

CODE	DESCRIPTION	WEIGHT (KG)
360240	3600 x 2400	450.00

**SUPER DESTIL 3600 X 2100**

FORMWORK

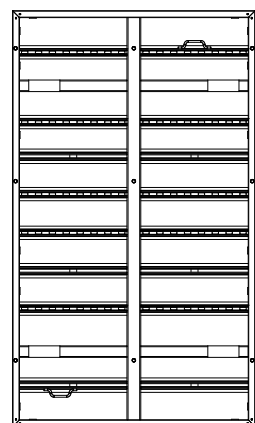

CODE	DESCRIPTION	WEIGHT (KG)
360210	3600 x 2100	374.00

**SUPER DESTIL 3600 X 1800**

FORMWORK

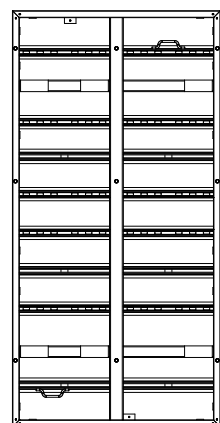

CODE	DESCRIPTION	WEIGHT (KG)
360180	3600 x 1800	336.00

**DESTIL ACCESSORIES**

QUICK ACTING CLAMP

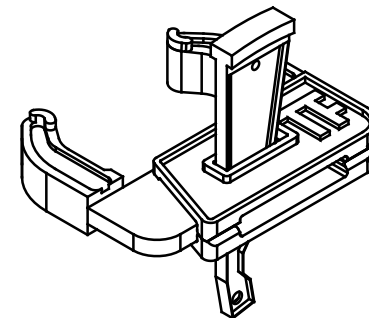

CODE	DESCRIPTION	WEIGHT (KG)
CC0008	Quick acting clamp	3.50

Used to connect adjoining formwork modules and may be placed at any point of border frame, preferably near the stiffeners.

**DESTIL ACCESSORIES**

MULTI FUNCTION CLAMP

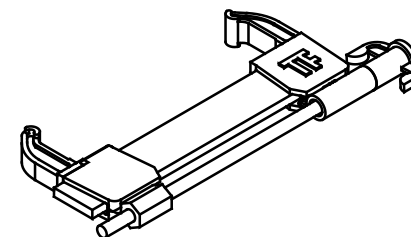

CODE	DESCRIPTION	WEIGHT (KG)
CC0009	Multi function clamp	5.50

Used to connect formwork modules and to allow compensations up to 200 mm width. May be placed at any point of border frames, preferably near the stiffenings.

**DESTIL ACCESSORIES**

SUPER PLATE NUT DW15

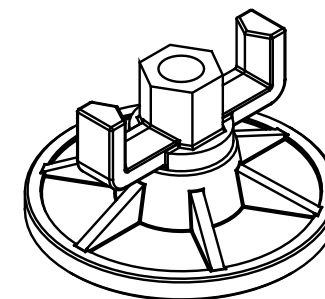

CODE	DESCRIPTION	WEIGHT (KG)
CC0045	Super plate nut DW15 (ø150)	1.50
CC0001	Super plate nut DW15 (ø130)	1.30

Screwed on the tie rods in order to lock up bindings (2 plates needed for each bar). Admissible load =90 kN (according to regulation DIN 18216).

**DESTIL ACCESSORIES**

PLATE NUT DW15

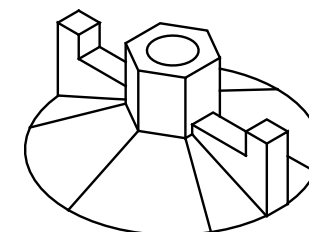

CODE	DESCRIPTION	WEIGHT (KG)
CC0002	Plate nut DW15 (ø110)	0.70
CC0046	Plate nut DW15 (ø130)	1.25

Used to fix and lock up the Universal fixing bolt, Universal fixing bolt for waling, and the Stop-end tie clamp.

**DESTIL ACCESSORIES**

PLATE NUT DW15 (ø60)

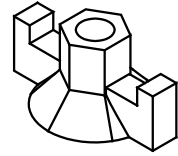

CODE	DESCRIPTION	WEIGHT (KG)
CC0003	Plate nut DW15 (ø60)	0.60

Used to block and lock up the Fixed bracket.

**DESTIL ACCESSORIES**

UNIVERSAL FIXING BOLT

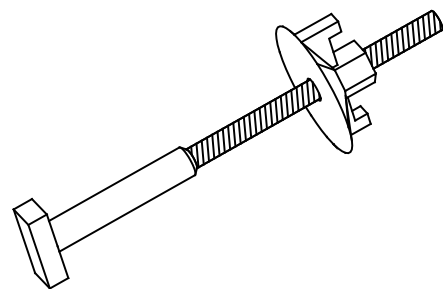

CODE	DESCRIPTION	WEIGHT (KG)
CC0019	Universal fixing bolt 330	1.30
CC0042	Universal fixing bolt 230	1.20
CC0050	Universal fixing bolt 180	1.10
CC0051	Universal fixing bolt 145	0.90

Ties up universal module formwork, 900 mm, with any other standard module in case of columns and external corners. Also used as an alternative to Quick acting clamp for fixing adjoining formwork modules. Completed with Plate nut D15 (Ø 110).

**DESTIL ACCESSORIES**

TIE ROD DW15



CODE	DESCRIPTION	WEIGHT (KG)
CC0060	Tie rod (L=650 mm)	0.94
CC0061	Tie rod (L=850 mm)	1.23
CC0014	Tie rod (L=1000 mm)	1.50
CC0062	Tie rod (L=1200 mm)	1.74
CC0063	Tie rod (L=1500 mm)	2.18
CC0064	Tie rod (L=2000 mm)	2.90
CC0065	Tie rod (L=2200 mm)	3.19
CC0066	Tie rod (L=2500 mm)	3.63
CC0067	Tie rod (L=3000 mm)	4.35
CC0068	Tie rod (L=4000 mm)	5.80
CC0069	Tie rod (L=5000 mm)	7.25
CC0070	Tie rod (L=6000 mm)	8.70

The bars can be reused; but prior to casting they should be put in plastic tube, type 22/26. For correct usage the bar should be equipped with appropriate accessories (Super plate nuts or Hexagon nuts or Plate nuts D15).

Admissible load: 90 kN (according to regulation DIN 18216)

Ultimate load: 190 kN (according to regulation DIN 18216)

NOTE: To avoid rupture or deformations, the bars should not be warmed-up or welded.

**DESTIL ACCESSORIES**

UNIVERSAL WALING

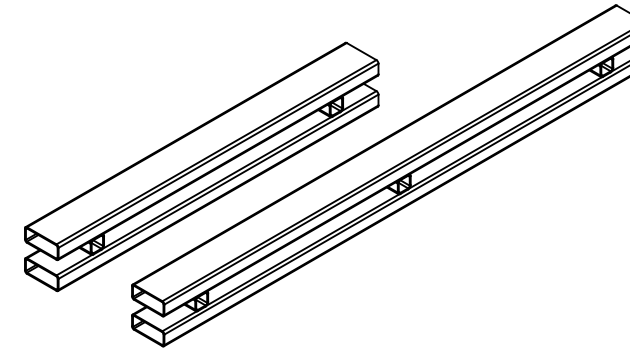

CODE	DESCRIPTION	WEIGHT (KG)
CC0011	Universal waling L=900 mm	16.00
CC0012	Universal waling L=1500 mm	25.00

Produced in two sizes and can be used in compensation areas and/or to rigidify the overlapped formworks. Fixed to the formwork with two Universal fixing bolts for waling.

**DESTIL ACCESSORIES**

UNIVERSAL CORNER WALING

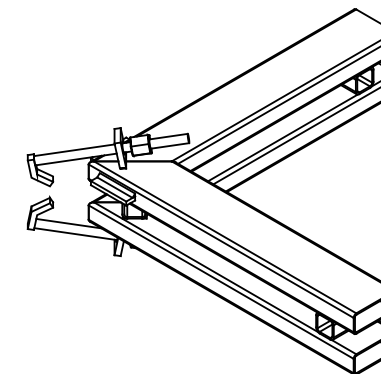

CODE	DESCRIPTION	WEIGHT (KG)
CC0013	Universal corner waling	15.20

Used in areas with 90°angle to block, lock up and align the adjoining formwork modules. Each corner waling is fixed with two Universal fixing bolt for waling.

**DESTIL ACCESSORIES**

UNIVERSAL FIXING BOLT FOR WALING

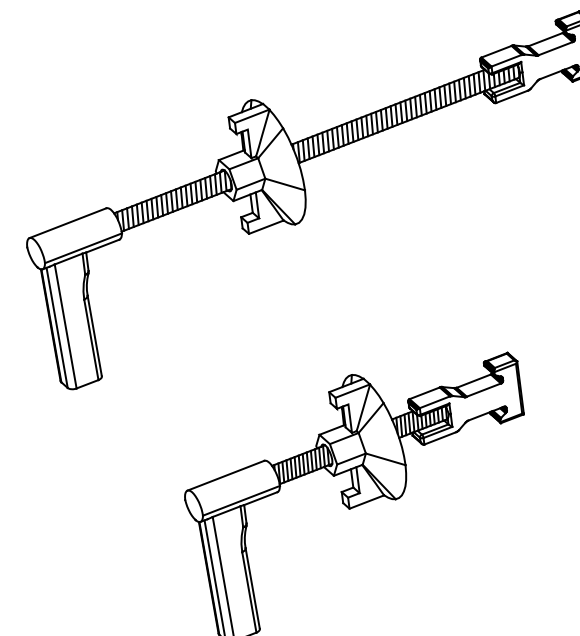

CODE	DESCRIPTION	WEIGHT (KG)
CC0016	Universal fixing bolt for waling L=250 mm	1.50
CC0017	Universal fixing bolt for waling L=400 mm	1.80

Code: CC0016 | Weight: 1.5 Kg

Fixes Universal waling and modules of frame formworks; can be joined with OMEGA profile; completed with Plate nut D15 (Ø 110).

Code: CC0017 | Weight: 1.8 Kg

Used to fix to the frame formwork elements of greater thickness (Examples: fixing framework and Contrast beam in supporting construction frames, etc...).

**DESTIL ACCESSORIES**

STOP/END TIE CLAMP

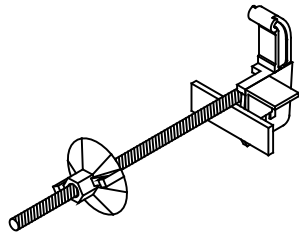

CODE	DESCRIPTION	WEIGHT (KG)
CC0018	Stopend tie clamp	1.70

In conjunction with Universal waling is used in variable position and affixed to the border frame to close two parallel formworks. It is completed with Plate nut D15 (Ø 110).

**DESTIL ACCESSORIES**

ANCHOR BRACKET

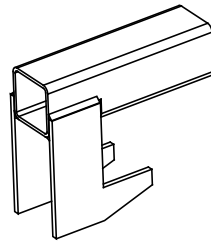

CODE	DESCRIPTION	WEIGHT (KG)
CC0024	Anchorage tube	1.50

Enables placement of tie rods above the profile edge in any position.

**DESTIL ACCESSORIES**

HEXAGON NUT DW15

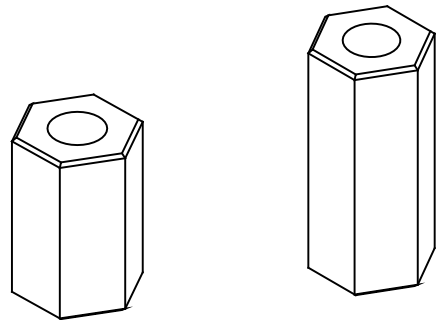

CODE	DESCRIPTION	WEIGHT (KG)
CC0004	Hexagon nut DW15 (L=50 mm)	0.30
CC0005	Hexagon nut DW15 (L=70 mm)	0.32

Code: CC0004 | Weight: 0.30 Kg  
Used to replace the Super plate nut in hard-to-reach places; in this case it's completed with pressure plate. Admissible load: 90 kN (according to regulation DIN 18216).  
Code: CC0005 | Weight: 0.30 Kg  
Used with Universal fixing bolt (L=205 mm), Universal fixing bolt (L=330 mm) and Universal angle tie bracket. Can be used as an alternative to Plate nuts in hard-to-reach places. Admissible load: 90 kN (according to regulation DIN 18216).

**DESTIL ACCESSORIES**

PRESSURE PLATE

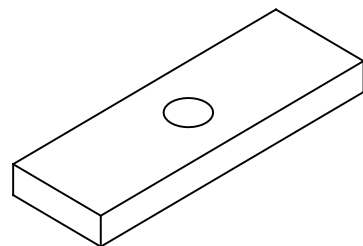

CODE	DESCRIPTION	WEIGHT (KG)
CC0015	Pressure plate	0.80

Used with Hexagon nut to tie down horizontally-oriented formwork; for execution of casting operations of limited height (about 1200 mm high).

**DESTIL ACCESSORIES**

COMPENSATION SHEETS

MADE TO ORDER

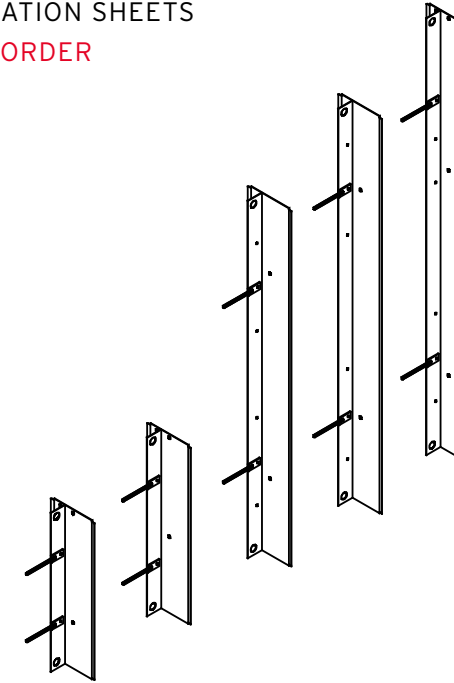

CODE	DESCRIPTION	WEIGHT (KG)
CC0006	Compensation sheets H=1200	23.50
CC0039	Compensation sheets H=1350	25.50
CC0040	Compensation sheets H=2700	46.50
CC0007	Compensation sheets H=3000	51.50
CC0041	Compensation sheets H=3300	56.50

Allows compensating the formwork module measures (from 10 to 300 mm) and also enables easier removing operations in closed spaces. Used in conjunction with Universal waling to which it must be fixed. The compensation sheet has appropriate holes planned for the tie rod's passage.

**DESTIL ACCESSORIES**

LIFTING HOOK

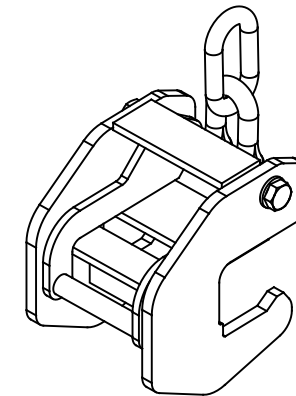

CODE	DESCRIPTION	WEIGHT (KG)
CC0010	Lifting hook	12.50

Used for lifting modules. Must be hooked-up with appropriate ropes which must not form middle angle greater than 60°. Each lifting hook has an admissible load of 1500 Kg. The lock system to the border profile of the formwork is auto-lock up. The lifting hook should be placed near the frame stiffenings.

**DESTIL ACCESSORIES**

FIXED BRACKET

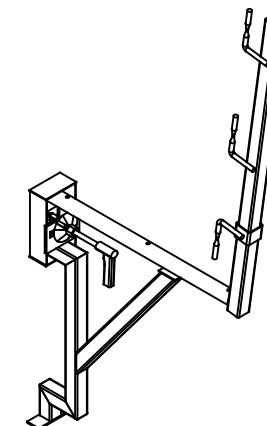

CODE	DESCRIPTION	WEIGHT (KG)
CC0022	Fixed bracket	16.80

Should be used for construction of casting platforms or service platforms together with Hy-plank boards with different spans (1140 mm, 1800 mm). Fixed bracket is joined to the formwork structure with appropriate fixing head. It is recommended to maintain the distance between two brackets not greater than 1.8 metres. The handrail should have timber board in the bottom, in the middle, and on the top of the vertical handrail structure; and the distance shouldn't be larger than 600 mm.



**DESTIL ACCESSORIES**

HINGED BRACKET  
MADE TO ORDER

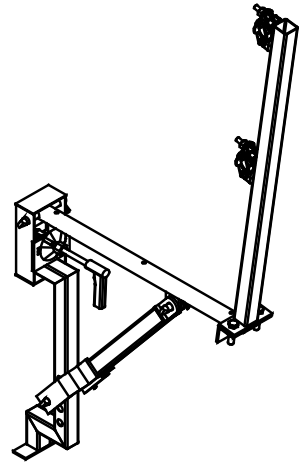

CODE	DESCRIPTION	WEIGHT (KG)
CC0023	Hinged bracket	20.00

Should be used for construction of casting platforms or service platforms together with Hy-plank boards that have different spans (1140 mm, 1800 mm). The access to the work platforms and casting platforms is granted with appropriate steel platform module with manhole place and appropriate ladder. Hinged bracket is joined to the formwork structure with appropriate fixing head. The adjustment devices allows reaching any required span due to usage of steel floor panels; an appropriate adjustment allows its employment also for the inclined walls.

**DESTIL ACCESSORIES**

PANEL STRUT

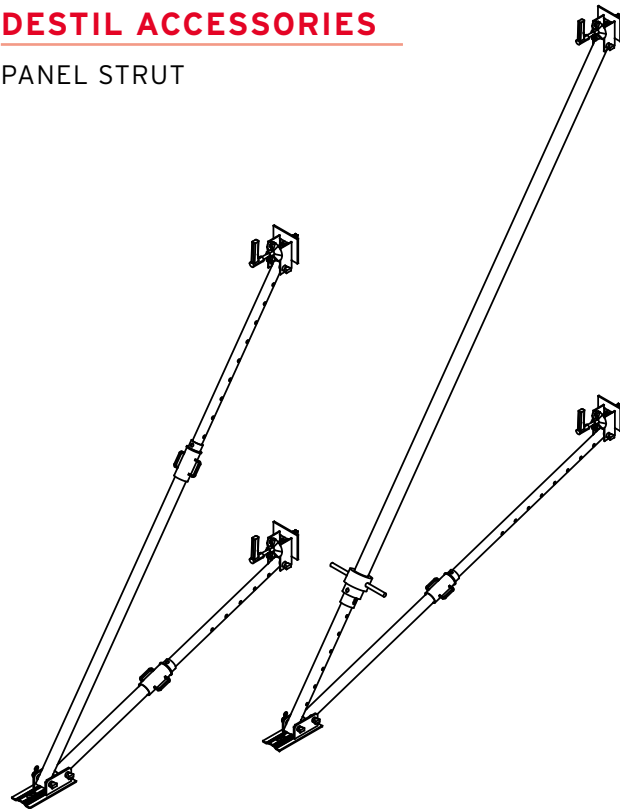

CODE	DESCRIPTION	WEIGHT (KG)
CC0025	Panel strut L=3400 mm	40.00
CC0026	Panel strut L=5400 mm	71.40

Code: CC0025 | Weight: 40.0 Kg  
Panel strut allows the adjustment of formwork perfectly vertical and can reach up to 4.2 metres height. Has two telescopic arms; each of which has one Prop head which is suitable for anchorage to formwork at any point. The Prop shoe should be fixed to the ground in order to avoid turnover of the formwork.  
Code: CC0026 | Weight: 71.40 Kg  
As the previous one, allows to have formwork perfectly vertical and can reach up to 6.5 metres height. Has two telescopic arms; each of which has one Prop head which is suitable for anchorage to formwork at any point. The Prop shoe should be fixed to the ground in order to avoid turnover of the formwork.

**DESTIL ACCESSORIES**

PANEL STRUT LONG BRACE

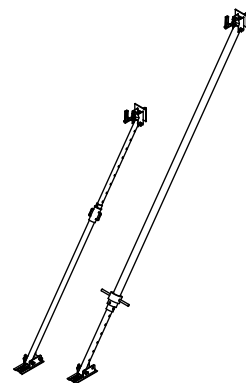

CODE	DESCRIPTION	WEIGHT (KG)
CC0036	Panel strut long brace L=3400 mm	23.10
CC0038	Panel strut long brace L=5400 mm	53.50

**DESTIL ACCESSORIES**

PANEL STRUT SHORT BRACE

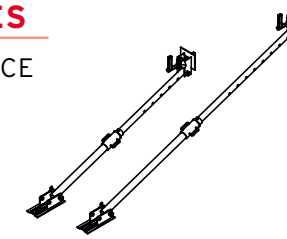

CODE	DESCRIPTION	WEIGHT (KG)
CC0035	Panel strut short brace L=1500 mm	16.70
CC0037	Panel strut short brace L=3400 mm	23.10

**DESTIL ACCESSORIES**

PROPS EXTENSION

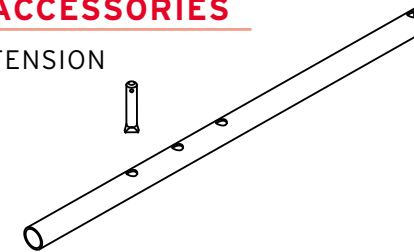

CODE	DESCRIPTION	WEIGHT (KG)
CC0027	Strut extension	17.00

Used to permit the vertical adjustment of two Panel struts (3400 or 5400 mm) up to 1000 mm. Each prop extension consists of two tubes completed with pins.

**DESTIL ACCESSORIES**

SPRING LOCKED CONNECTING PIN D20

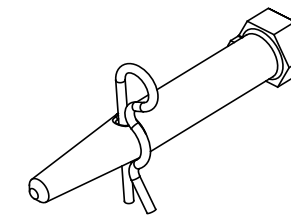

CODE	DESCRIPTION	WEIGHT (KG)
CC0021	Spring locked connecting pin D20	0.50

Used to fix the connection of Pouring Brackets and Plumbing Struts to formwork panels.

**SUPER DESTIL ACCESSORIES**

CONNECTION PLATE TYPE 1

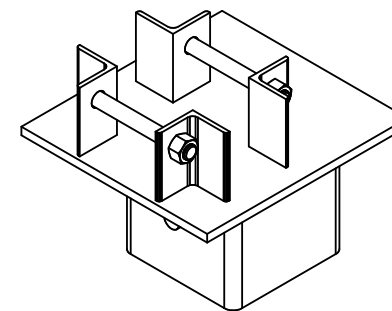

CODE	DESCRIPTION	WEIGHT (KG)
CC0120	Connection plate type 1	10.60

To be used in all single basic slab configurations and on the central 2400 element in wing configuration. It can be fixed to formwork panels by bolts or pins.

**SUPER DESTIL ACCESSORIES**

CONNECTION PLATE TYPE 2

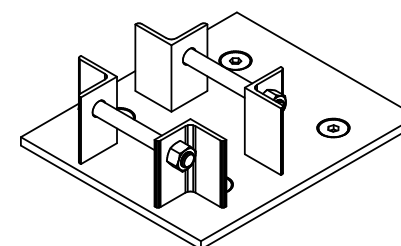

CODE	DESCRIPTION	WEIGHT (KG)
CC0121	Connection plate type 2	7.00

To be used for prop connection to lateral 1800 formwork elements, in wing configuration, and in combination with "Prop bracket-wing panel". It can be fixed to formwork panels by bolts or pins.



**SUPER DESTIL ACCESSORIES**

PROP BRACKET-WING PANEL

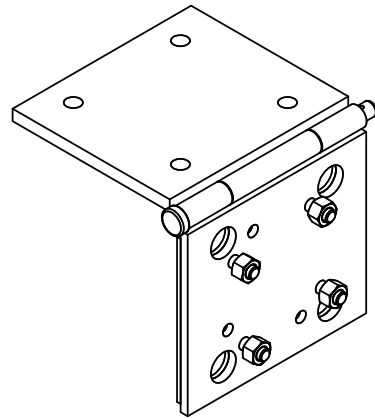

CODE	DESCRIPTION	WEIGHT (KG)
CC0122	Prop bracket-wing panel	14.00

To be used for prop connection to lateral 1800 formwork elements, in wing configuration, and in combination with "Connection plate type 2" to which is bolted.

**SUPER DESTIL ACCESSORIES**

FORMWORK TABLE HINGE

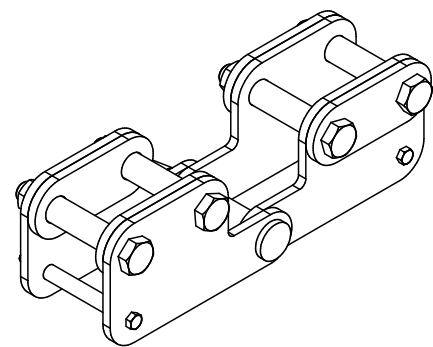

CODE	DESCRIPTION	WEIGHT (KG)
CC0123	Formwork table hinge	22.10

To be used to connect and to allow rotation between laterals (1800) and central (2400) formwork elements in wing configuration.

**SUPER DESTIL ACCESSORIES**

SUPER DESTIL PARAPET

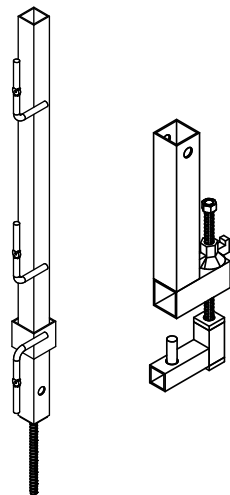

CODE	DESCRIPTION	WEIGHT (KG)
CC0124	Single parapet element	7.10
CC0125	Super Destil shoe	5.30

In combination with SUPER DESTIL SHOE can be locked in any position along the border formwork profile, either in horizontal (SLAB) configurations or in vertical (WALL) configurations. As SINGLE PARAPET ELEMENT can be fixed through the tie-holes (SLAB) or through the formwork profile lateral holes (WALL) using a DW15 nut.

**SUPER DESTIL ACCESSORIES**

INFILL BRACKET

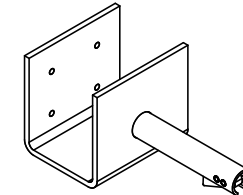

CODE	DESCRIPTION	WEIGHT (KG)
CC0126	Infill bracket	1.10

Is a self-locking bracket which allows to arrange compensations, using formwork profile lateral holes on SUPER DESTIL elements.

**SUPER DESTIL ACCESSORIES**

PROP LOCKING BRACKET

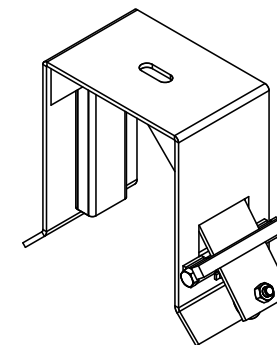

CODE	DESCRIPTION	WEIGHT (KG)
CC0127	Prop locking bracket	2.00

Is an accessory which allows to hold in horizontal position an ALU-PROP, in wing configuration during shifting operation.

**SUPER DESTIL ACCESSORIES**

WING CATCHING BRACKET

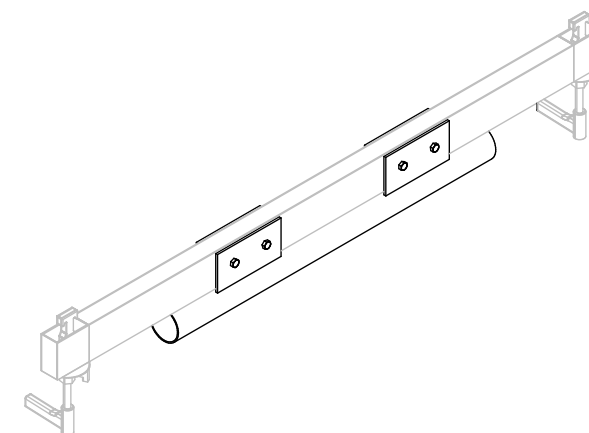

CODE	DESCRIPTION	WEIGHT (KG)
CC0128	Wing catching bracket	22.00

Accessory to be connected to lateral formwork in wing configuration, to allow formwork easy rotation during stripping phase.



**FOWLER**  
SCAFFOLD HOISTS FORMWORK

FRAMED  
FORMWORK  
DESTIL MINI

USER INFORMATION

## SAFETY WARNINGS

- The respect of these instructions does not exempt from compliance with all safety regulations in force in the country where you use the system.
- These instructions are intended for users of Fowler products and systems. Operators must be aware of the contents of this manual; in case they have difficulties in reading the same, contact Fowler Formwork Manager.
- The User's Manual instructions must always be available at the workplace for all operators.
- This manual, even if used in order to draw up a Method Statement, will not substitute it, and the Method Statement will remain an important and unavoidable site document, responsibility of the client.

- **Information and illustrations contained herein are relative to only the system in question, and therefore not exhaustive about the overall security; always refer to the applicable health and safety regulations in the area of use of the equipment.**
- **In relation to flow, configuration, installation, use and dismantling of equipment Strictly obey all instructions contained herein; failure to comply with them may result in serious injury to people, as well as extensive property damage.**
- Take every precaution consequently due to the climatic conditions of the site (i.e. in case of rain and/or ice to provide anti-slip measures etc.)
- Periodically verify, especially after severe weather conditions, any connection, wedge or any other connecting element, in order to avoid any possible system instability and consequent accidents.

# SUMMARY

FEATURES	75
FRAME DETAILS	76
ELEMENT CONNECTIONS	80
CLOSURE SOLUTIONS	83
CLOSURE / INFILL DIMENSIONS	84
ASSEMBLING INSTRUCTIONS	85
PANEL STRUTS	85
CORNERS	87
STOP ENDS	93
WALL OFFSET SOLUTIONS	95
COLUMNS	97
CIRCULAR FORMWORKS	99
SHAFTS	101
LIFTING INSTRUCTIONS	102
SHIFTING & STORAGE	103
ITEMS LIST	104

## FEATURES

DESTIL MINI wall framed formwork is the new Fowler system, which can be handled as a handset and with a crane, thanks to its reduced panel weight. DESTIL MINI offers Fowler systems usual efficiency and reduction of total costs, with reduced weight, through the following features:

**MODULARITY:** A formwork system with a wide range of modularity available in heights of 3000 mm, 2700 mm, 1500 mm, and 1200 mm and widths starting from 300 mm and up to 900 with 150 mm increments between panels. A choice for any necessity.

**STEEL:** High resistance Steel, S315MC

**Frame depth:** 92 mm

**Finishing:** hot dip galvanization

**CRANE ISN'T MANDATORY:** The relevant weight reduction (panels weigh around 30 kg/sqm) permit to assemble, dismantle and shift the system components by handset!

**MAX CONCRETE PRESSURE:**

60 kN/m<sup>2</sup> up to H 3m (no vertical stacking of panels)

40 kN/m<sup>2</sup> over H 3m (with stacking of panels)

**HIGH-QUALITY PLYWOOD:** 15 mm birch quality-plywood or a Plastic-coated plywood that lasts 3 times longer.

**HIGH COMPATIBILITY:** The formworks are perfectly compatible with other formwork systems currently leading the market.

**LONG LIFE:** Frames and profiles are hot dipped galvanized both inside and outside for a long life span.

**FAST CONNECTION OF PANEL:** The special geometry of the steel profiles allows the connection of frame modules in any position by Quick-acting clamp and Multi- function clamp.

**CORNERS AND CIRCULAR WALLS:** All corners, articulated corners and panels for circular walls or columns are available.

**TECHNICAL ASSISTANCE:** Fowler ensures technical assistance pre- and post-selling.

**ACCESSORIES:** Full range of accessories to guarantee a fast and safe system application. DESTIL MINI steel frame system allows the following:

- Vertical works
- Horizontal works
- Formworks supported by shoring system
- Climbing formworks suitable i.e. for towers and bridge piers
- Dam formworks
- Elevator shafts
- Single-faced concreting
- Tunnel solutions



**DESTIL MINI FRAMED FORMWORK**

**Material:** Hot-rolled highly resistance steel S355MC, according to EN 10149 part 1/ part 2 and DIN EN 10051

**Admissible load:** Up to H 3m 60 kN/m<sup>2</sup>  
Over H 3m 40kN/m<sup>2</sup>

**Finishing:** Hot Dip galvanization

**Panel:** Birch multilayer panel, 15mm thick, Plastic coated

1 Highly resistant steel frame, 92mm deep, with perimeter concavity adapted for insertion of connection clamps in any position.

2 "Slotted" perimetral holes for higher versatility (i.e.: Formwork modules can be joined with bolts or with Universal fixing bolt).

3 Anchor holes PVC protections for easier operations with tie rods.

4 Continous slotted holes on perimetral profiles and circular holes on transversal profiles for easy and geometrically free fixing of system accessories.

5 Birch multilayer panel, 15mm thick, with 220 g/m<sup>2</sup> superficial phenolic treatment, easy to clean, and protected by a silicon seal process. On request a plastic-coated plywood that last three times longer can be provided .

Wide range modularity of framed formwork together with availability of different size panels, permits any kind, size, and measure of concrete works.

High compatibility with other formwork systems currently leading the market.

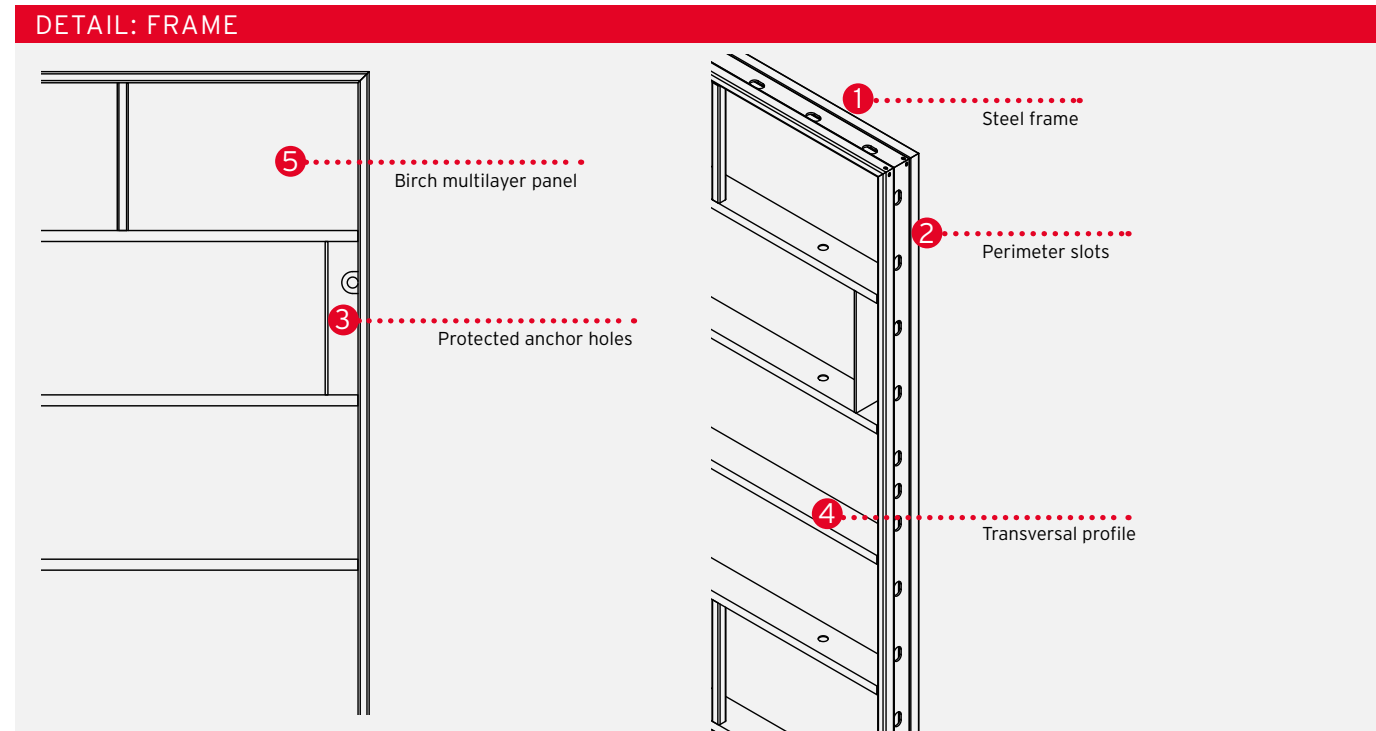

**FEATURES**

- Lightness
- Modularity
- High compatibility with other formwork systems Currently on the market
- Complete range of accessories
- Rapid formwork erection, dismantling and shifting on-site
- Respect of measure tolerances and great care in producing every system component
- Wide range of steel frame elements
- Pre-and post-selling assistance
- Attention and respect of safety factors

The steel frame system allows the construction of the following:

- Vertical works
- Horizontal works
- Formwork supported by shoring system
- Climbing formwork for towers and bridge piers
- Dam formwork
- Formwork for elevator shafts
- Single-faced concreting
- Tunnels

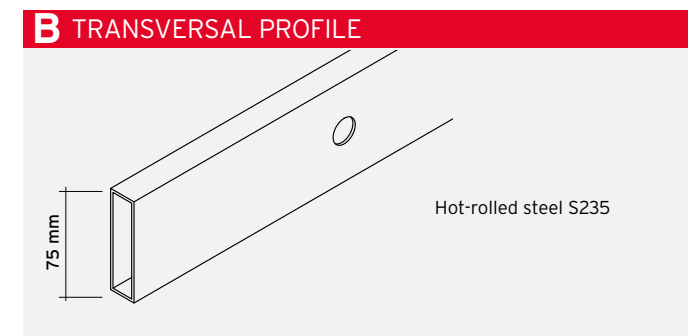
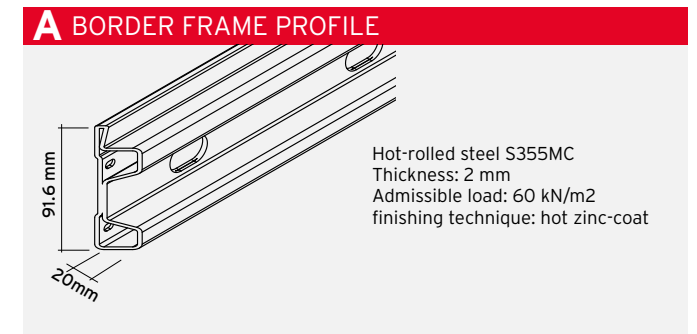
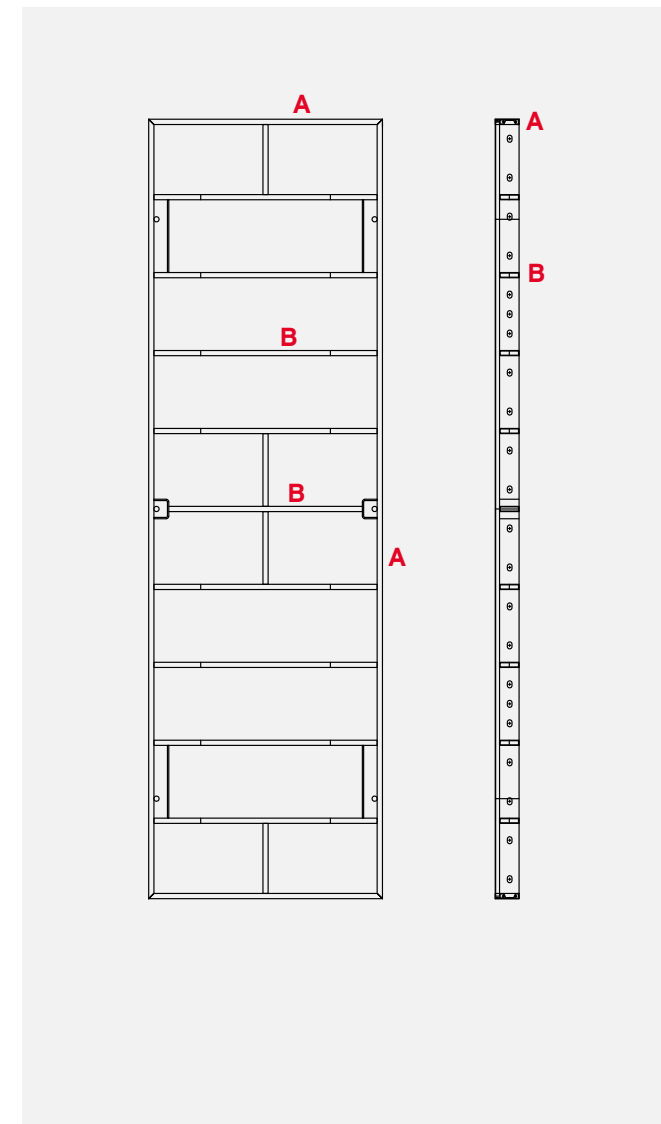

**DESTIL MINI FRAME  
FORMWORK ELEMENT**

Logical modular system in steps of 150 mm. The heights and the widths of Destil Mini elements frame create a modular system logical and simple to use making the formwork particularly flexible and cost effective.

- Easy planning and forming
- Adjustment of the height and width in steps of 150 mm
- Few compensations required
- Clear positioning of junctions
- 5 element widths
- 4 element heights

With this wide range you can form any geometry.

**ELEMENTS WIDTH**

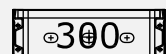
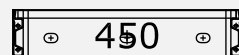
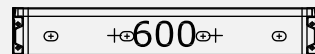
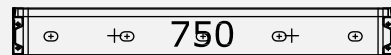
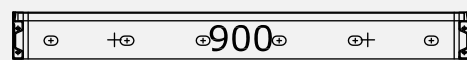

**UNIVERSAL ELEMENTS WIDTH**

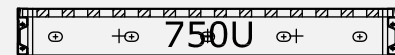
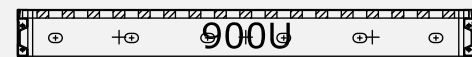

**ELEMENTS HEIGHT**

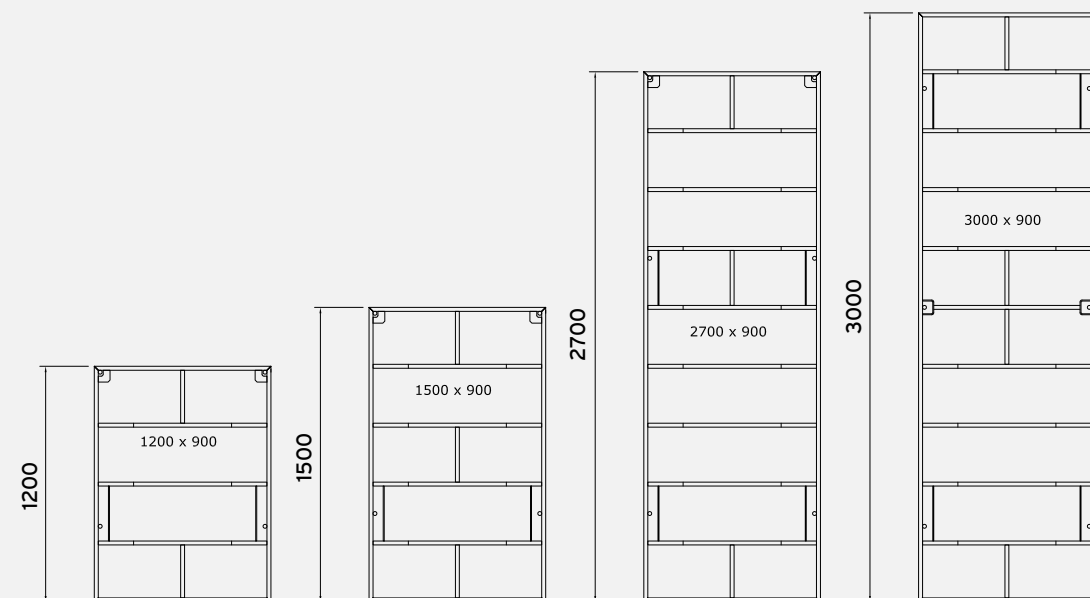

**UNIVERSAL ELEMENTS HEIGHT**

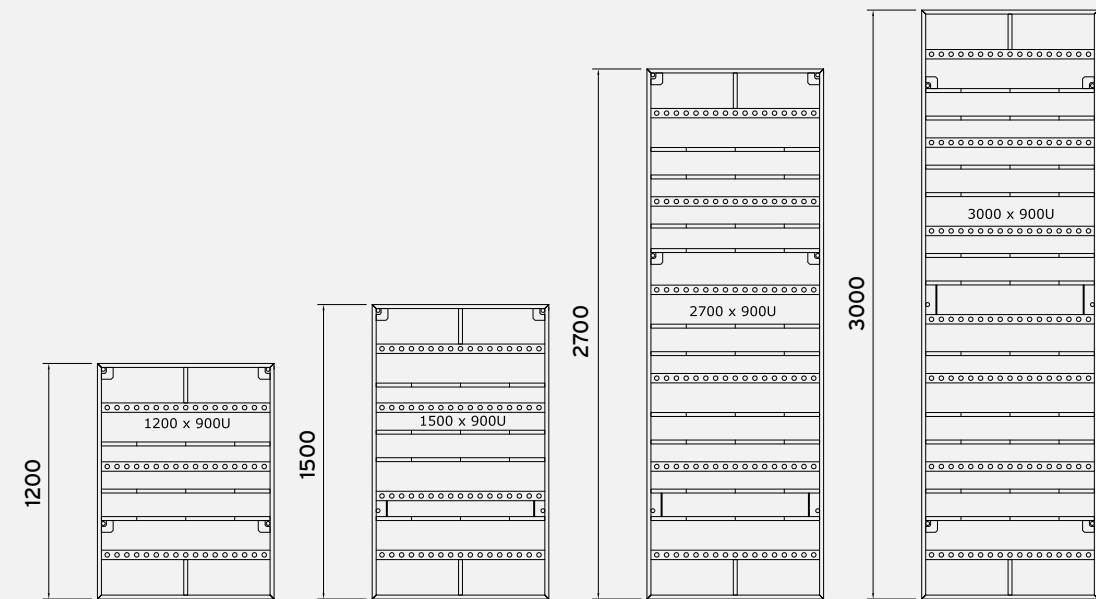

**COMBINATION EXAMPLES**

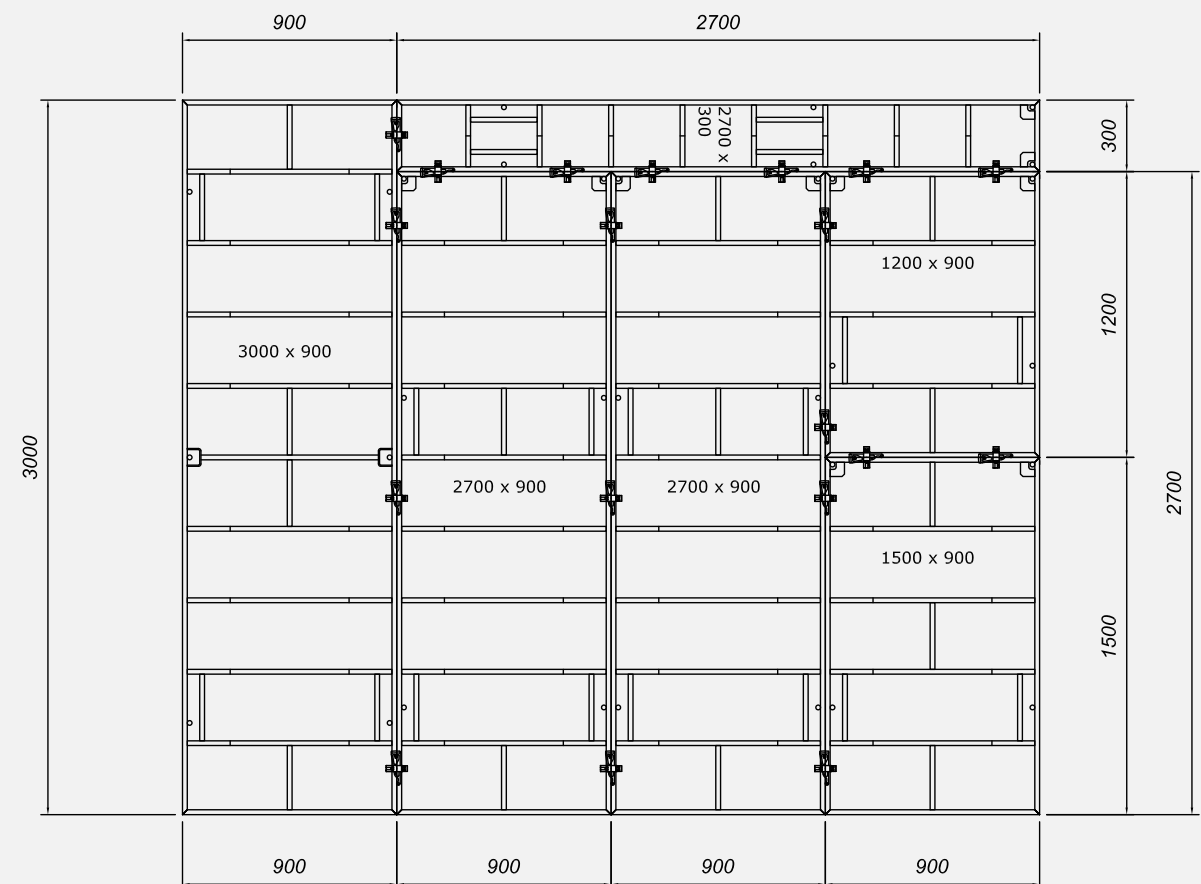

**DESTIL MINI ELEMENT CONNECTION**

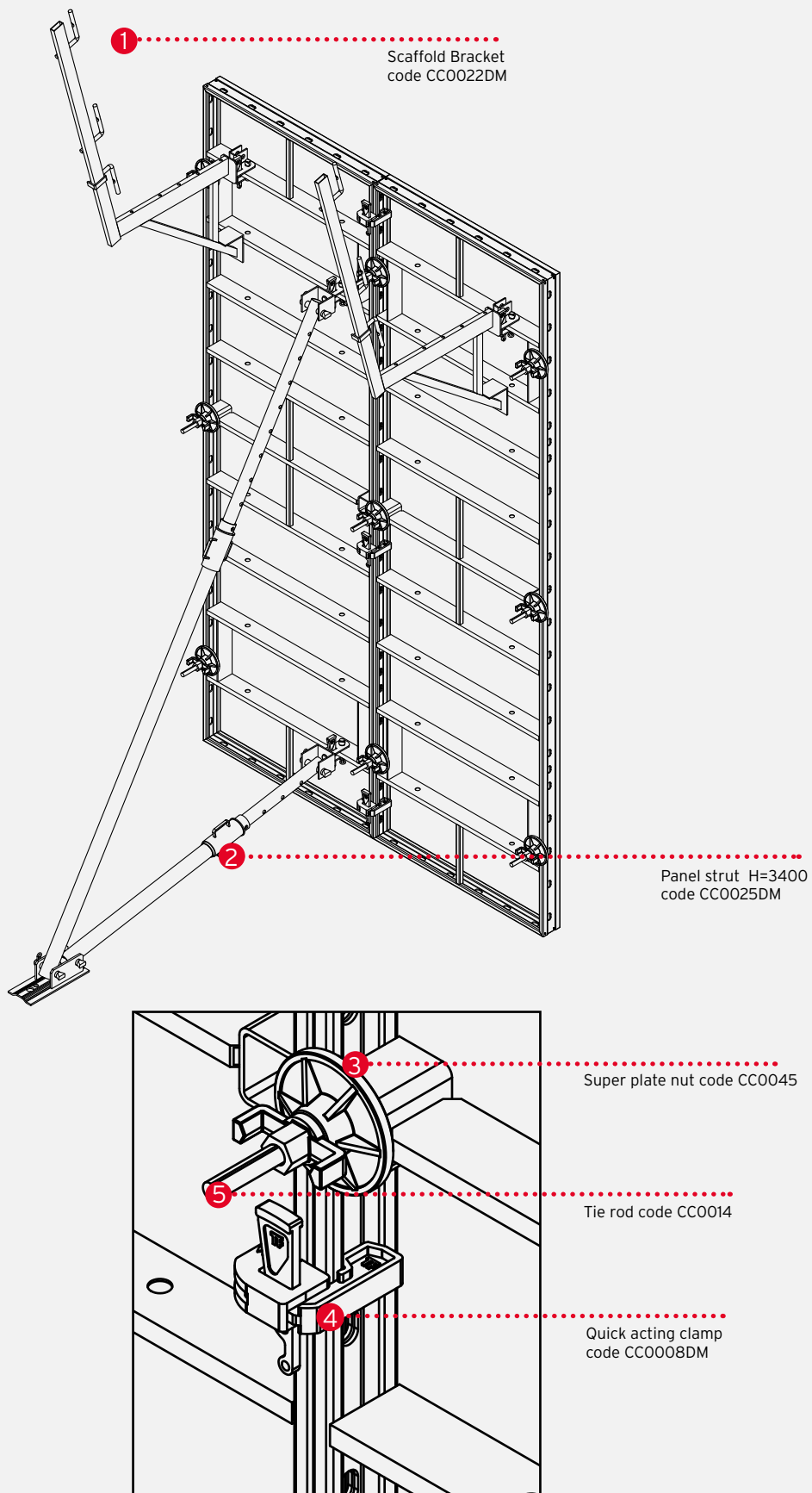

**DESTIL MINI SCAFFOLD BRACKET**

To be used for installation of walking platforms or service platforms combined with wooden or steel planks. The scaffold bracket is easily joined to the formwork panels through its fixing head. It is recommended to contain the distance between two scaffold brackets to no more than 1.8 metres. The walking platforms must have timber board at the bottom, the middle and top of the scaffold bracket post. The access to the walking platforms have to be guaranteed by suitable ladders. When platforms are installed at top of the formwork, also the opposite side of the scaffold bracket should be protected by a suitable railing. Any other outer openings should be closed according to local safety regulations.

Connection with formwork module

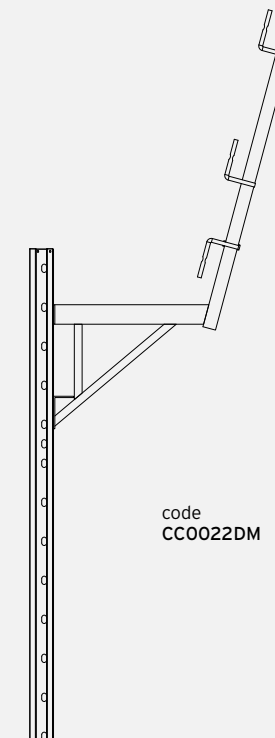
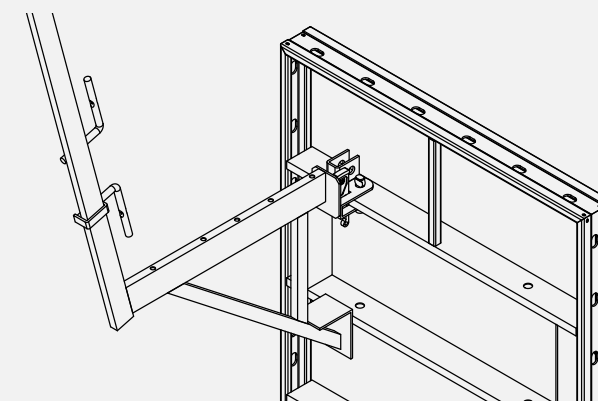

**PANEL STRUT / PUSH PULL PROP**

Panel strut allows the adjustment of the formwork verticality and can reach up to 4.2 metres in height. It's equipped with two telescopic arms; both have one Prop head which is suitable for anchorage to formwork at any point. The Prop shoe must be fixed to the ground in order to avoid turnover of the formwork.

Prop shoe

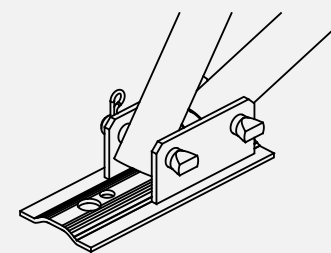

Connection with formwork

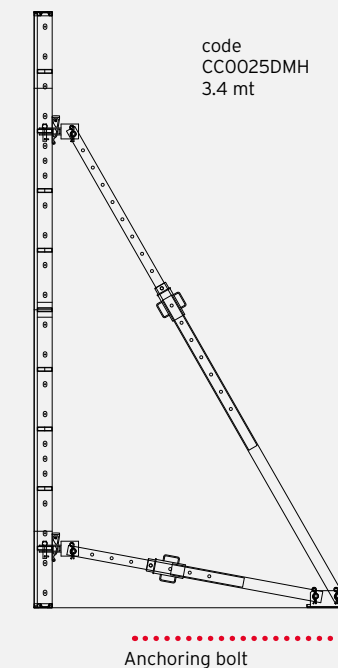
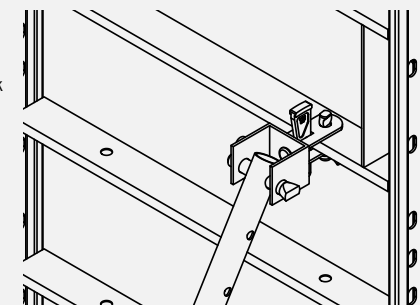



**PLATE NUT D15 (ø120/130)**

code  
CC0001

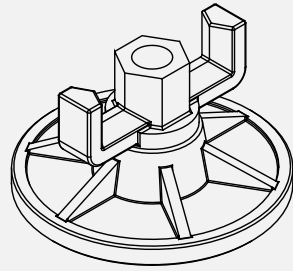

Screwed on the tie rods in order to lock up bindings (2 plates needed for each bar). Admissible load =90 kN (according to regulation DIN 18216).

**QUICK ACTING CLAMP**

Connect the adjacent formwork elements together. It can be placed at any point of the frame's perimeter, preferably close to the stiffeners.

Destil Mini Quick Acting Clamp and Destil Mini Multi Function Clamp:

- Align perfectly the elements creating connections faster and resistant to traction
- Don't have components of small dimensions that may be lost
- The wedge mechanism avoids clogging of concrete.

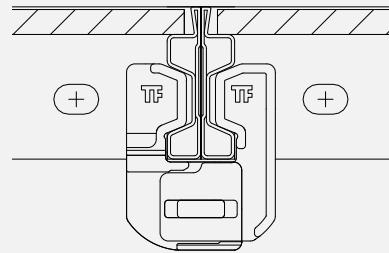

code  
CC0008DM

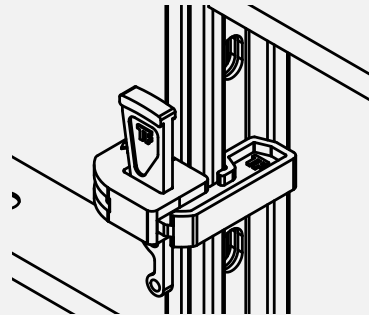

- Permitted tensile force: 10.0 kN
- Permitted shear force: 5.0 kN
- Moment: 0.2 kNm

Thanks to the notch that runs along the frame profile, the connection of the elements may occur at any point. This allows a continuous junction in height of elements in any position.

VERTICAL ELEMENTS	
Height elements (mt)	Clamps number
1.20	2
1.50	2
2.70	3
3.00	3

HORIZONTAL ELEMENTS	
Width elements (mt)	Clamps number
0.30	1
0.45	1
0.60	2
0.75	2
0.90	2

**TIE ROD**

Used to fix corresponding formwork during the casting operations. Produced in standard length of 6 metres and cut to necessary length on the construction site. The bars can be reused after the works; but prior to casting, it's recommended to insert them in PVC tube, type 22/26, for an easier extraction. For correct usage the bar should be equipped with appropriate accessories (Super plate nuts or Hexagon nuts or Plate nuts D15). Admissible load: 90 kN (according to regulation DIN 18216) Ultimate load: 190 kN (according to regulation DIN 18216). Admissible load: 120 kN (with 1.6 safety factor).

NOTE: To avoid rupture or deformations, the bars should not be warmed-up or welded.

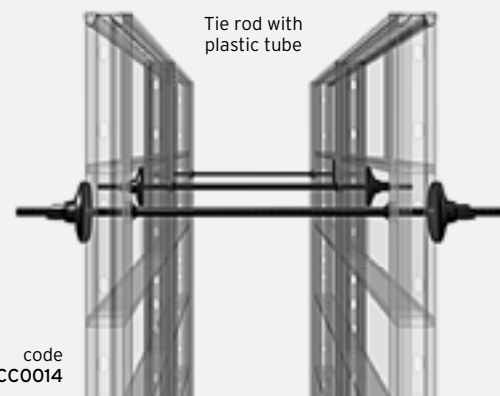

code  
CC0014

**DESTIL MINI CLOSURE SOLUTIONS**

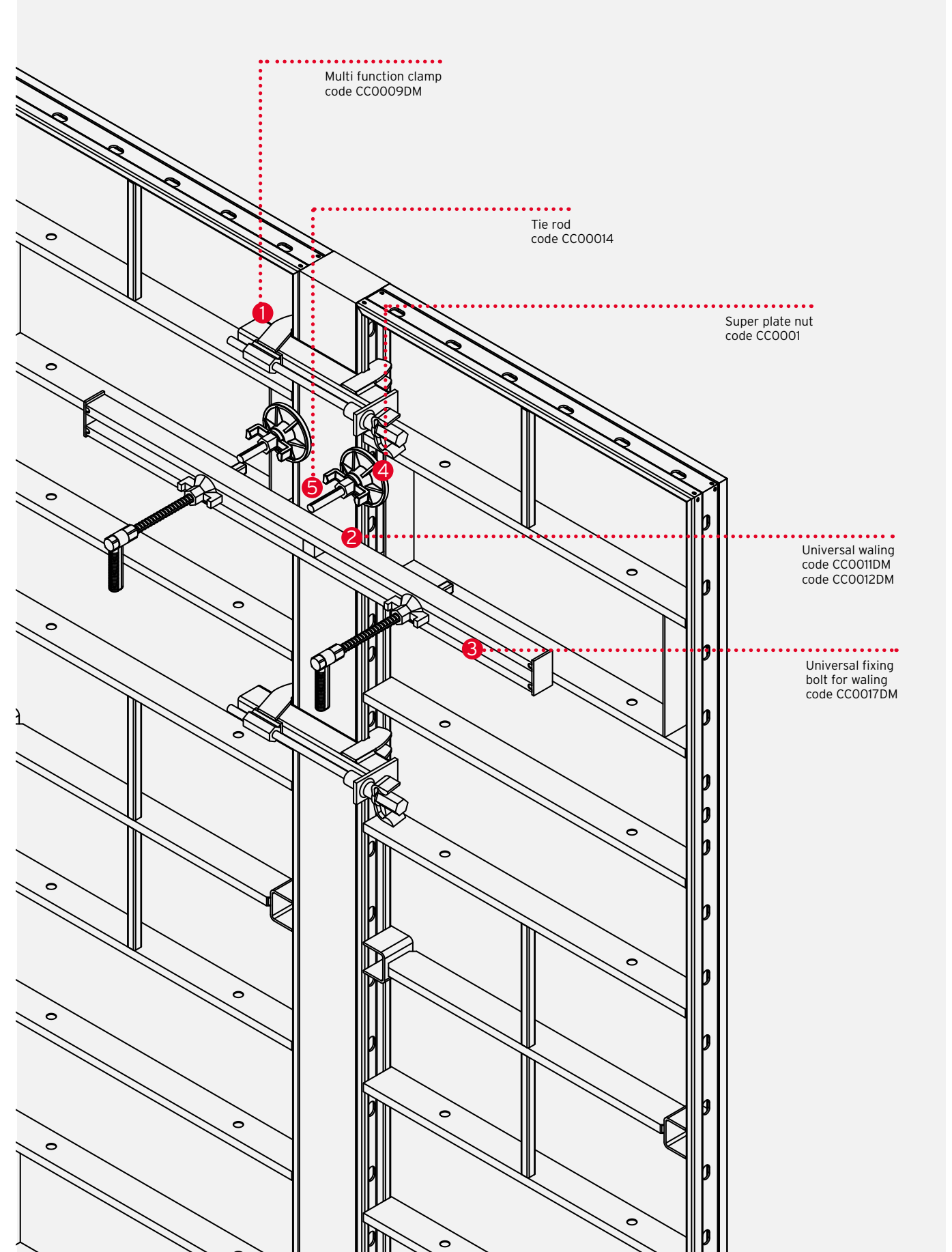

**CLOSURES UP TO 150 mm**

Wall infill, from 0 to 150 mm, using squared timbers or wooden boards, multi function clamp for the connection of the elements and universal waling for alignment.

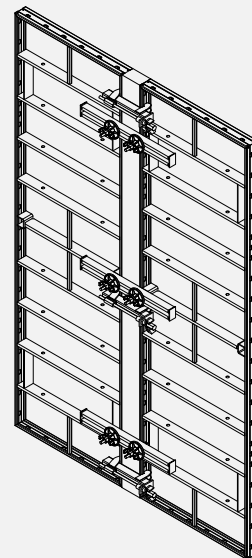
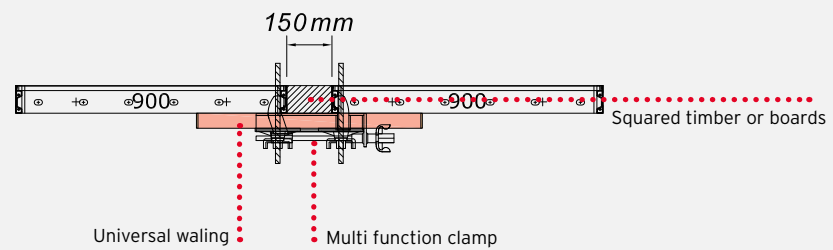

**CLOSURES UP TO 500 mm**

Wall infill, from 0 to 500 mm, using wooden boards or wooden panels.

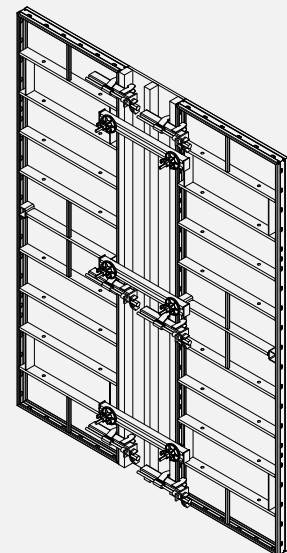
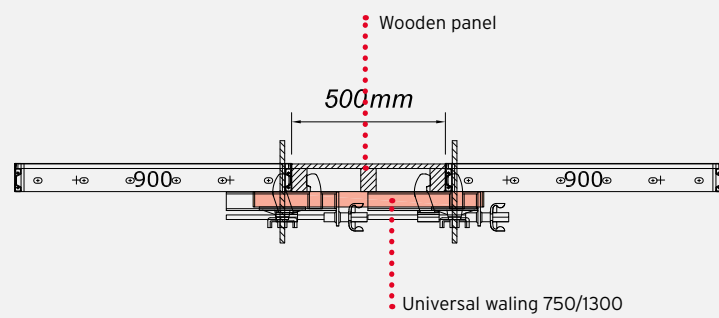

**UNIVERSAL WALING FIXING DETAIL**

Connection of the universal waling to the framework using the universal fixing device for waling and tube profile.

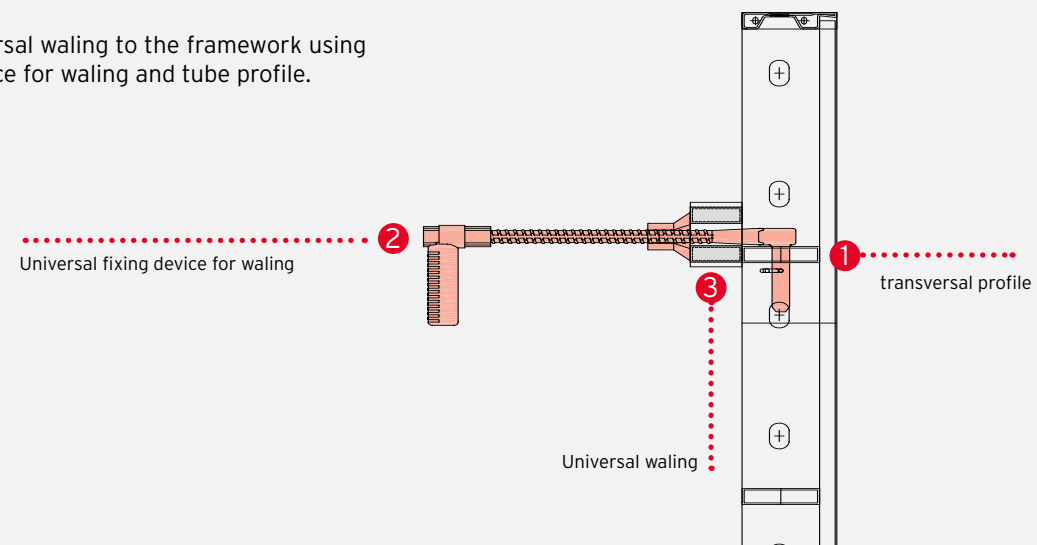

**PANEL STRUTS L=3400 mm / PUSH PULL PROPS**

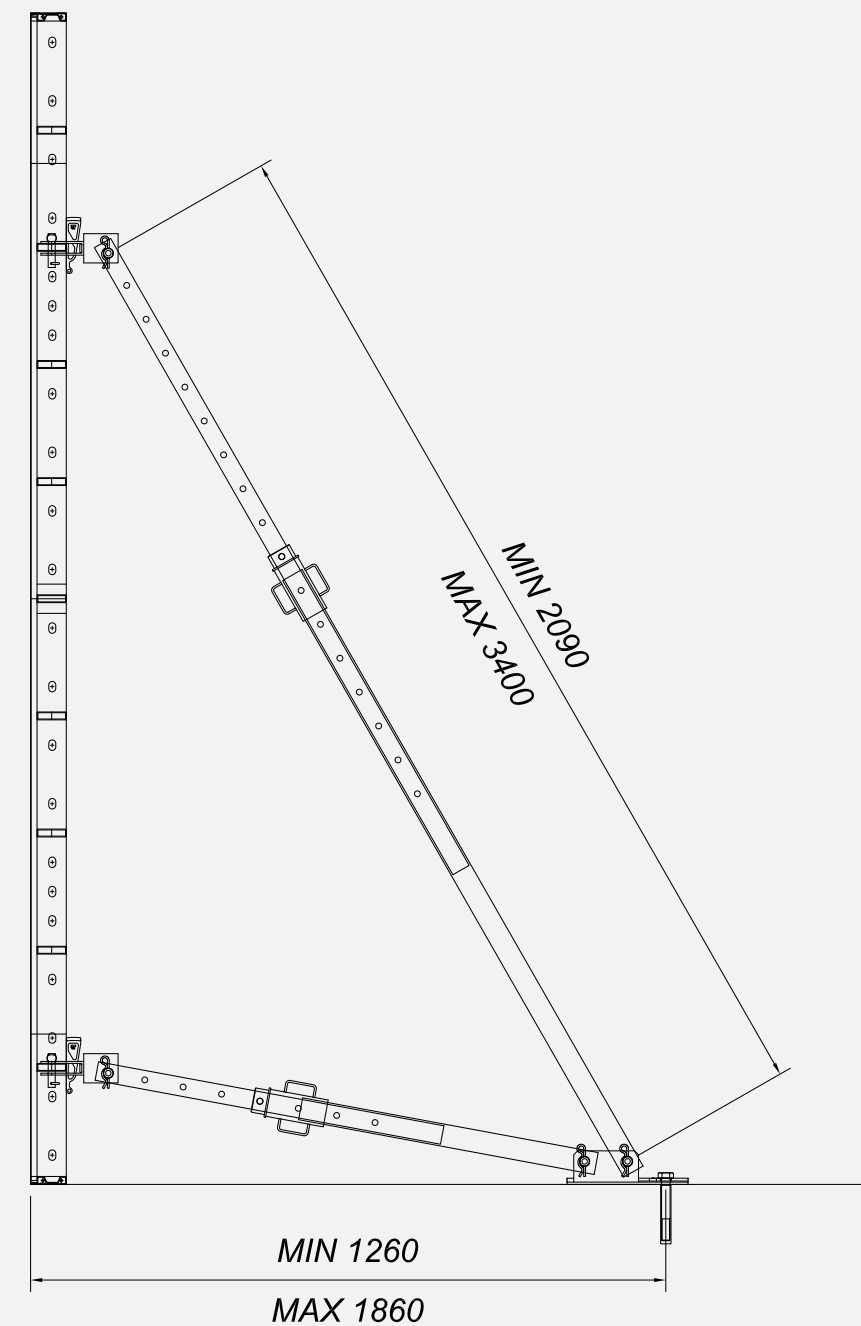

Panel struts used for plumbing and installation operations. Panel Strut L=3400 mm: minimum and maximum possible extension.

MAXIMUM STRESS OF THE PANEL STRUT L=3400 mm

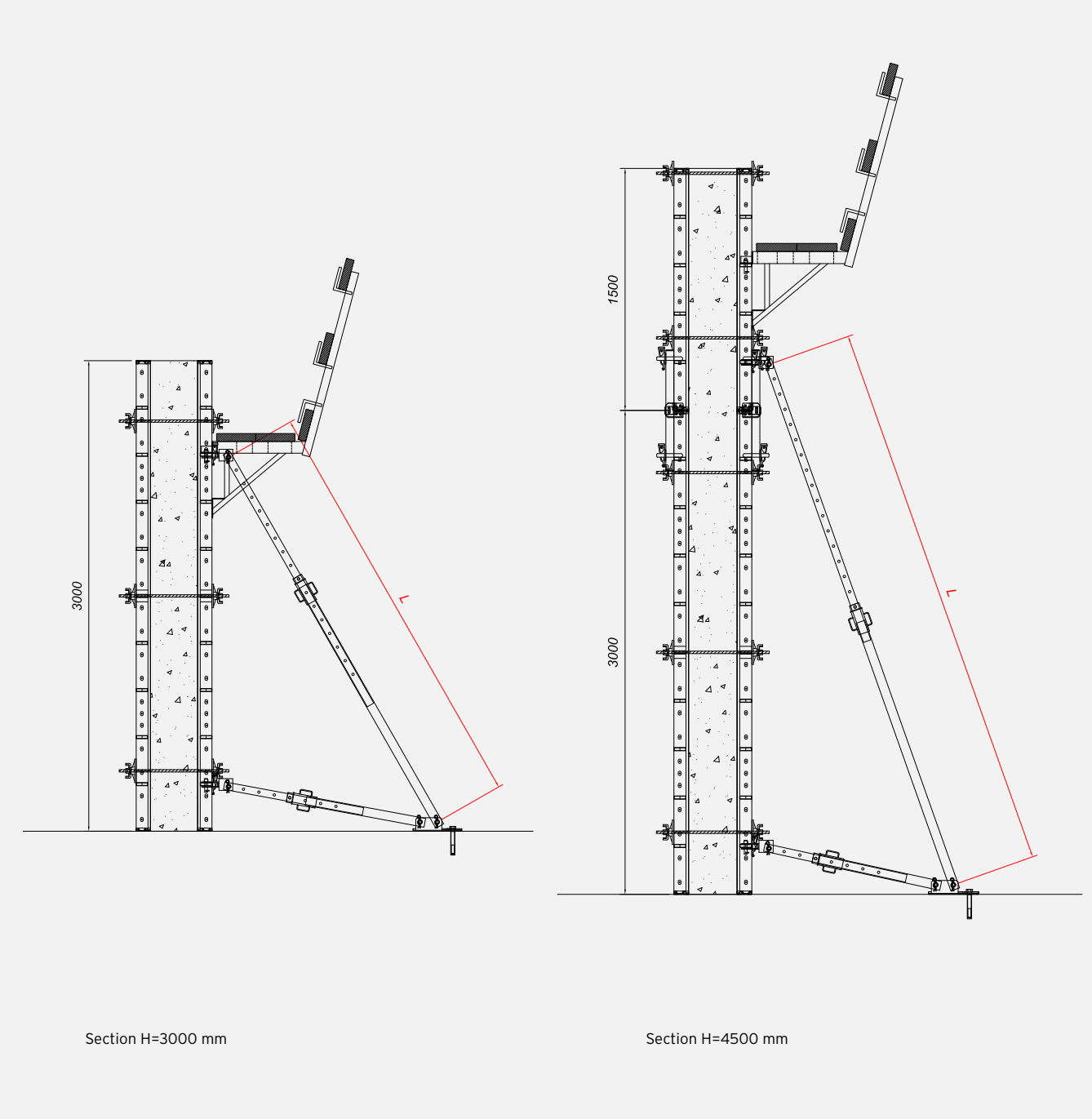

EXTENSION L (MT)	ADM COMPRESSION ACTION (KN)	ADM TENSILE ACTION (KN)
2.0	22.0	<b>15.0</b>
2.2	21.0	
2.4	17.5	
2.6	14.5	
2.8	12.5	
3.0	11.0	
3.2	9.5	
3.4	8.0	

90° ANGLE WITH DESTIL MINI UNIVERSAL ELEMENT

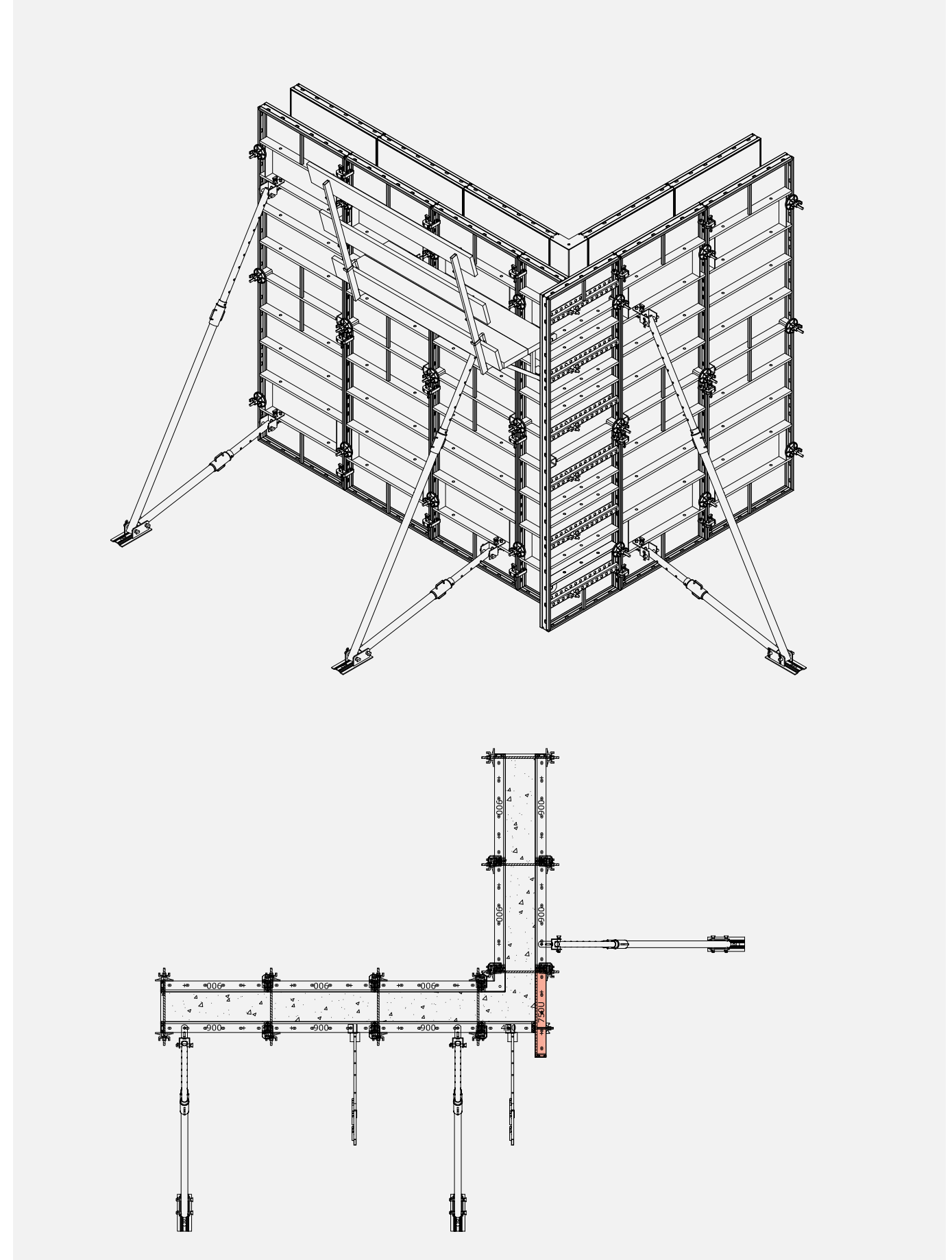



90° ANGLE WITH DESTIL MINI INT. & EXT. CORNERS

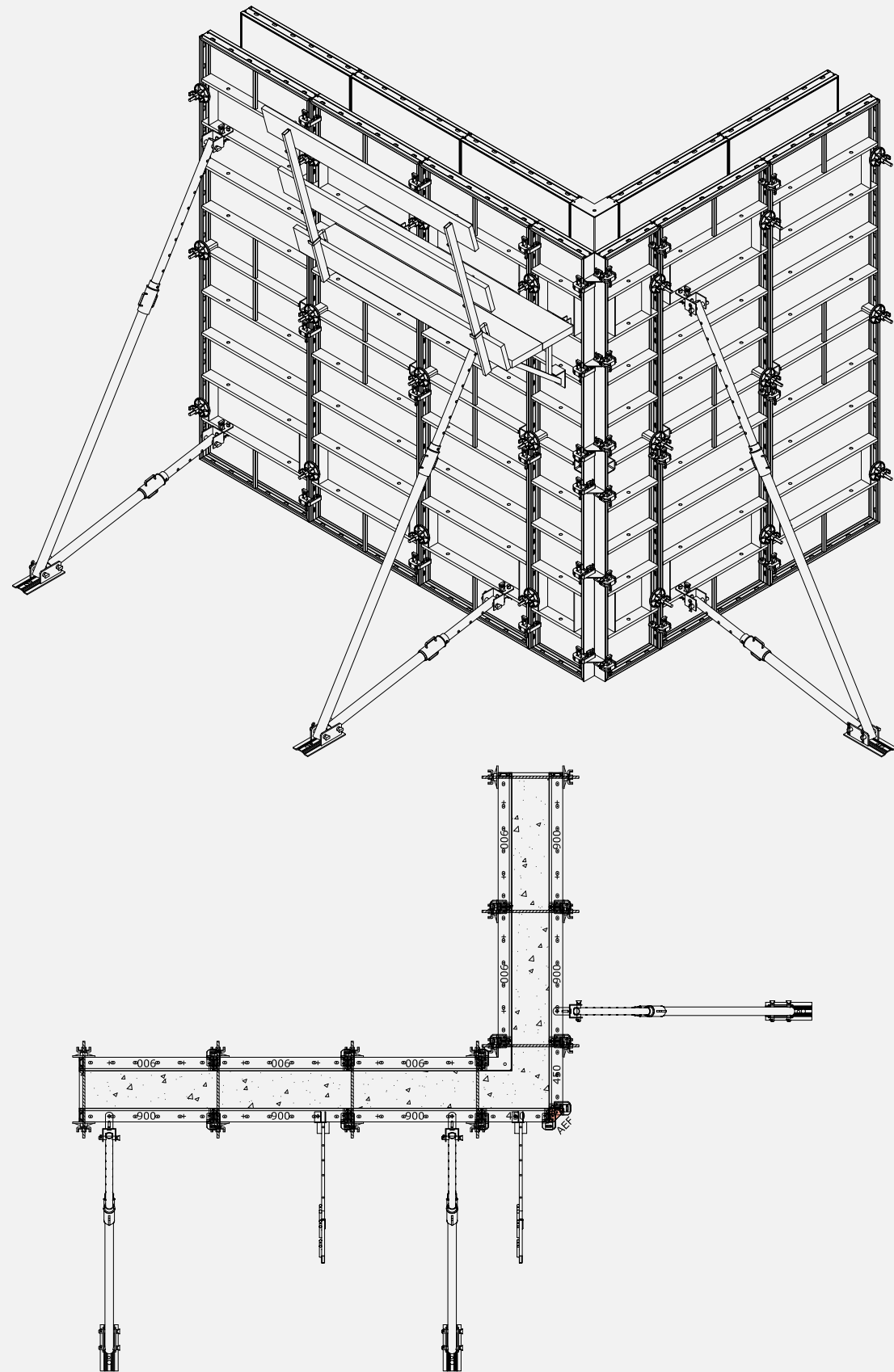

ACUTE ANGLE WITH DESTIL MINI HINGED CORNERS

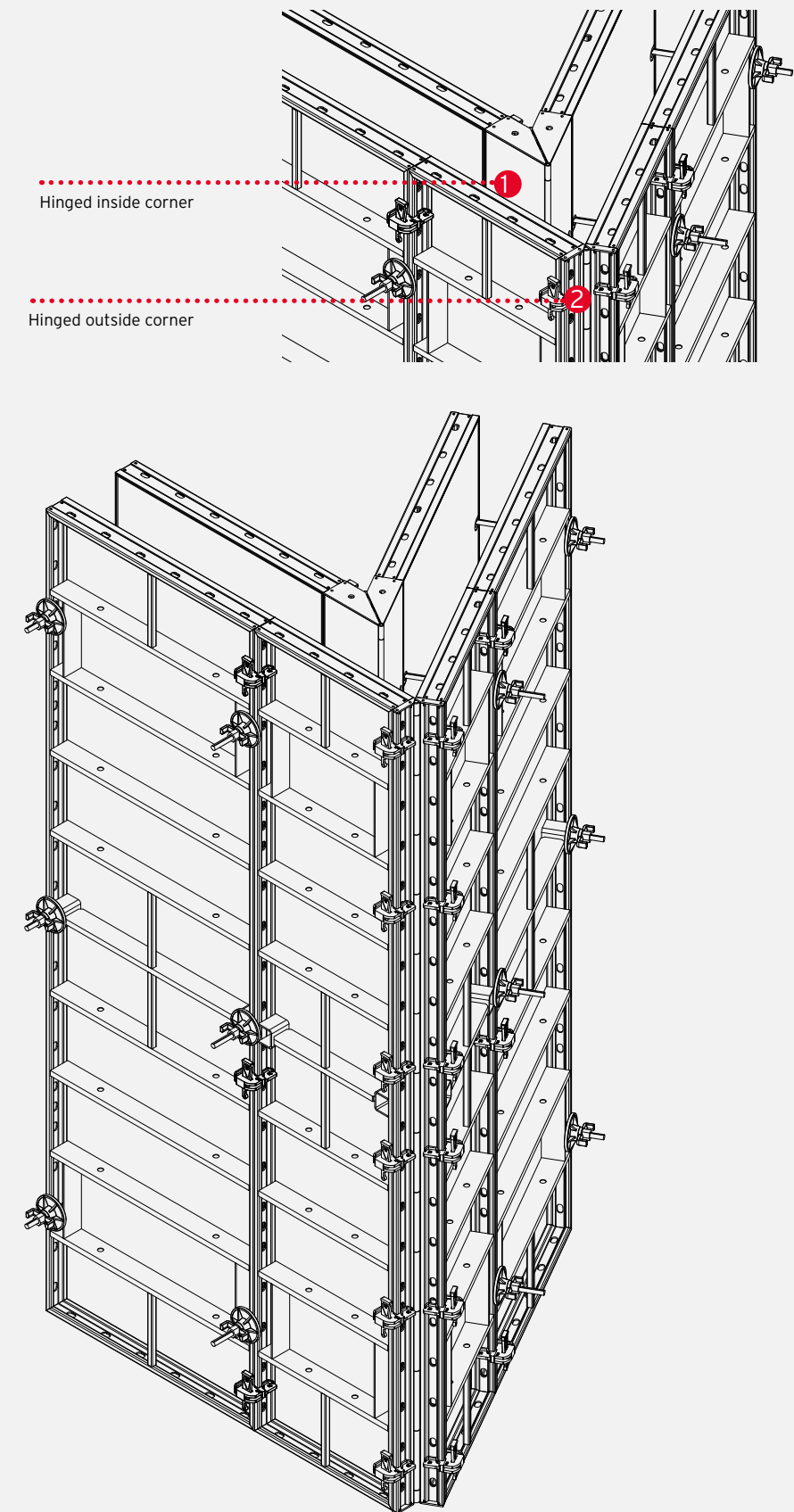

EXAMPLE OF ACUTE ANGLE

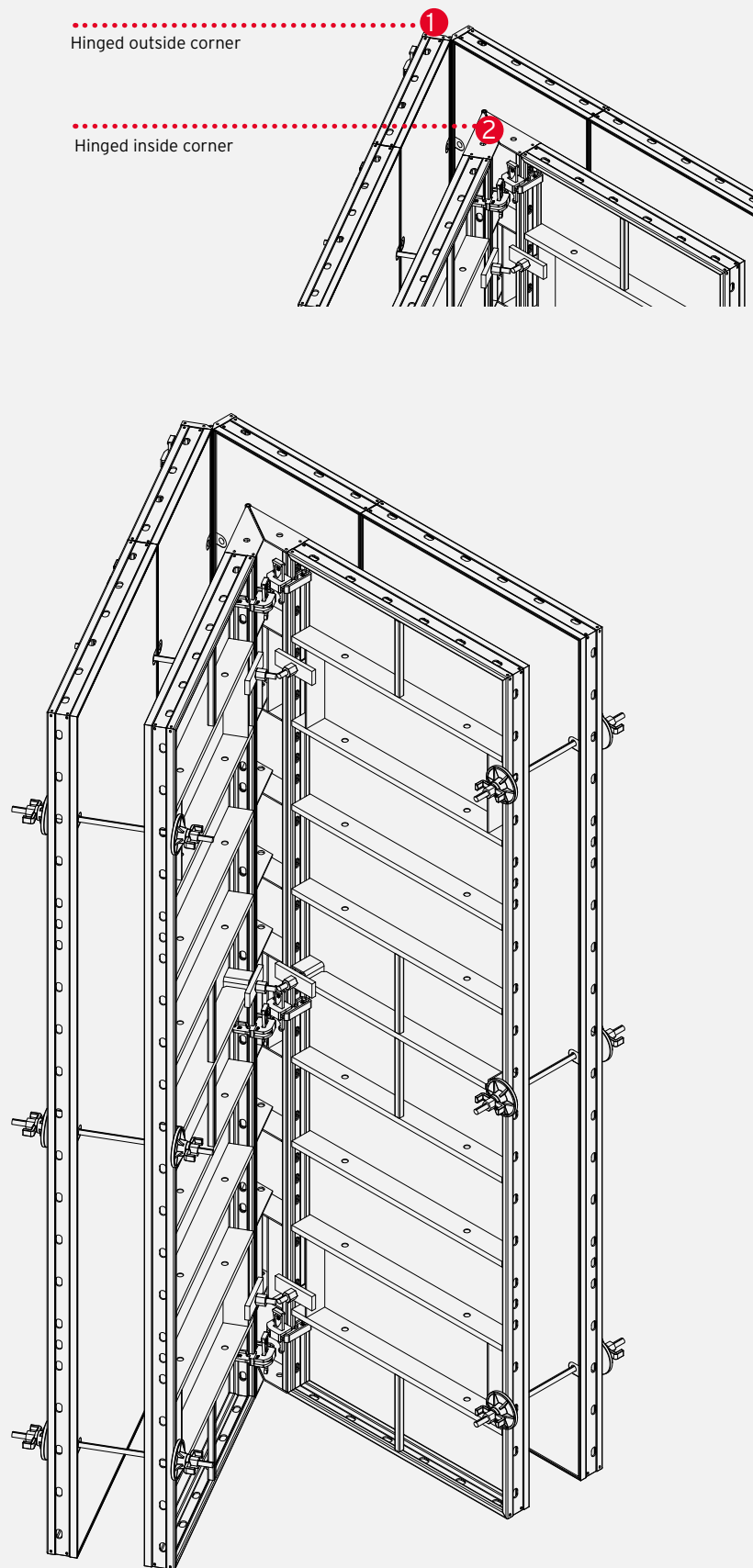

EXAMPLE OF 60° ANGLE

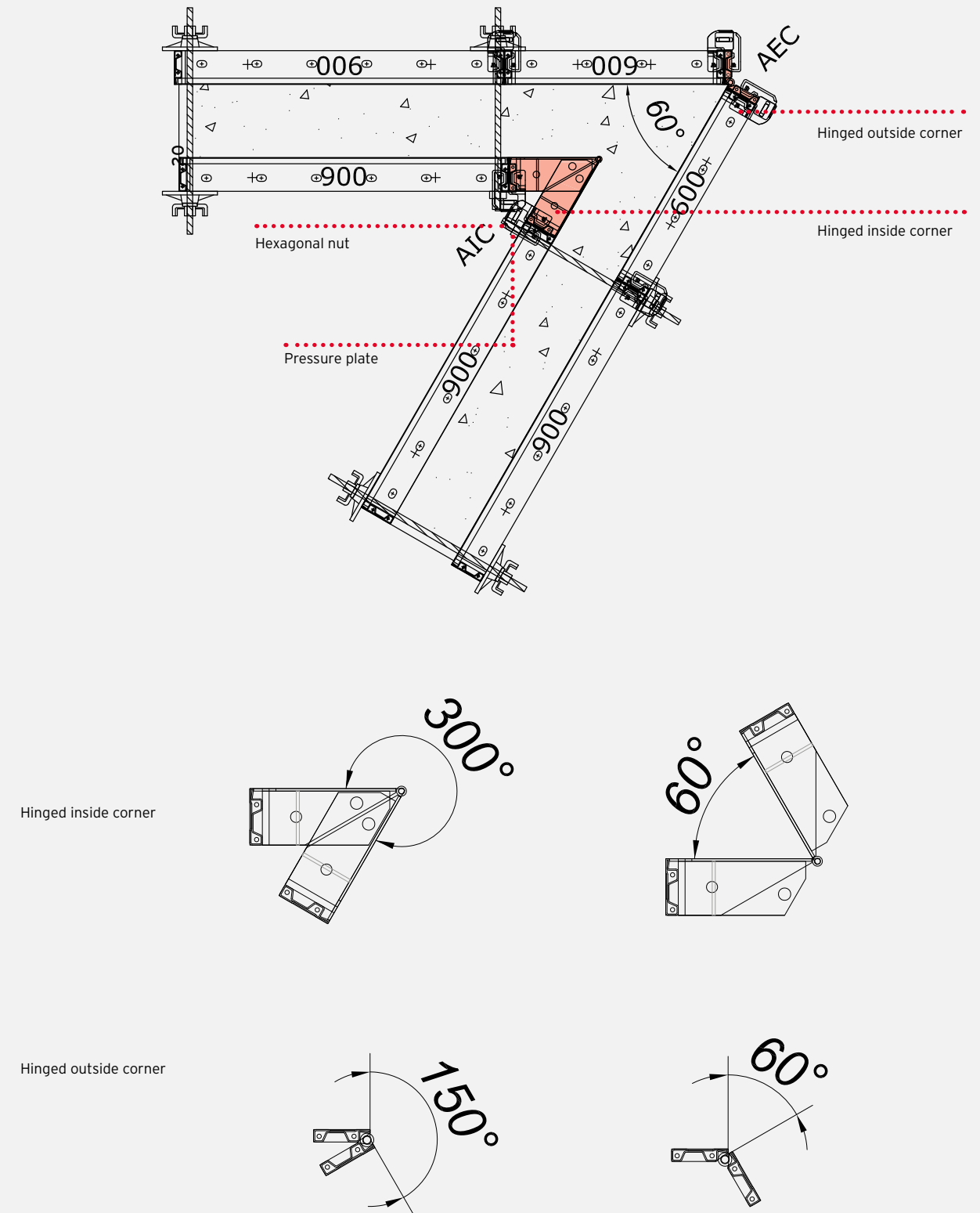

60° angle made using Destil Mini hinged inside and outside corners.

**150° ANGLE**

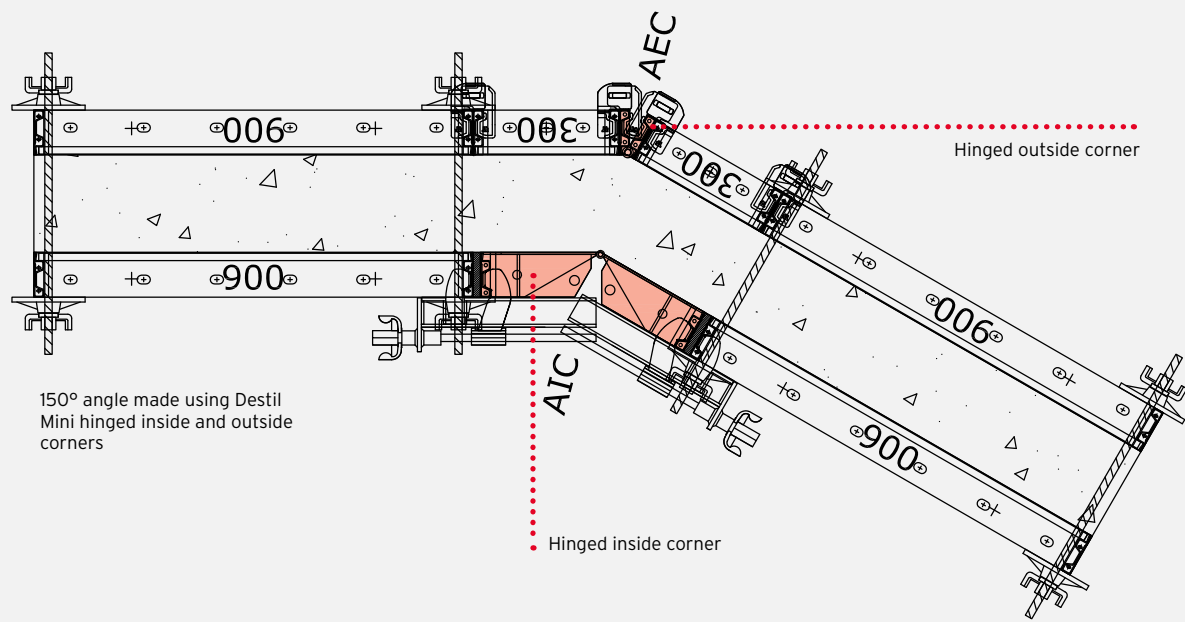

150° angle made using Destil Mini hinged inside and outside corners

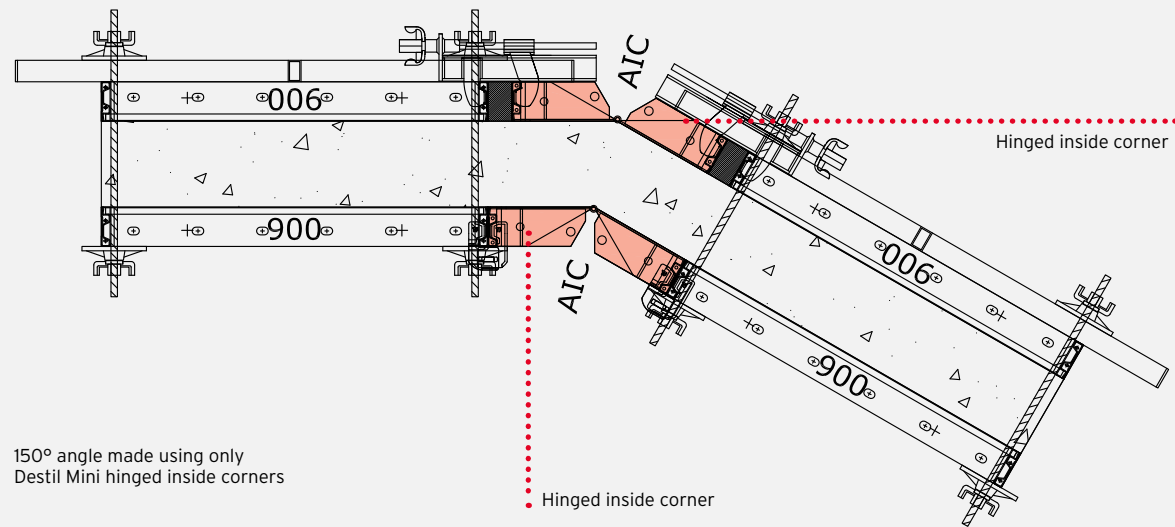

150° angle made using only Destil Mini hinged inside corners

**STOP ENDS BY STANDARD ELEMENT & UNIVERSAL WALING**

Stop end made using universal waling and universal fixing bolt.

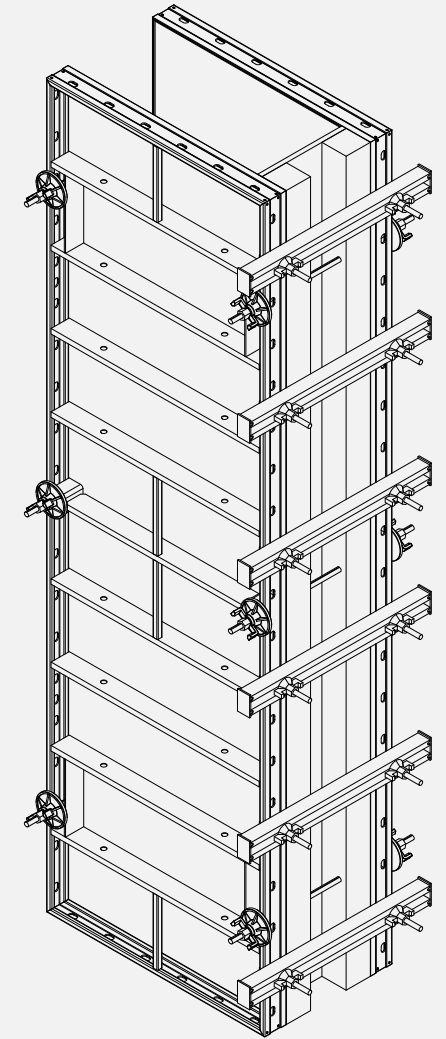

**CLOSURE**

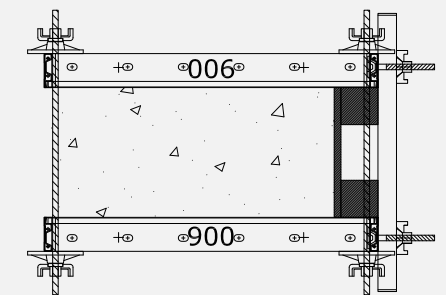
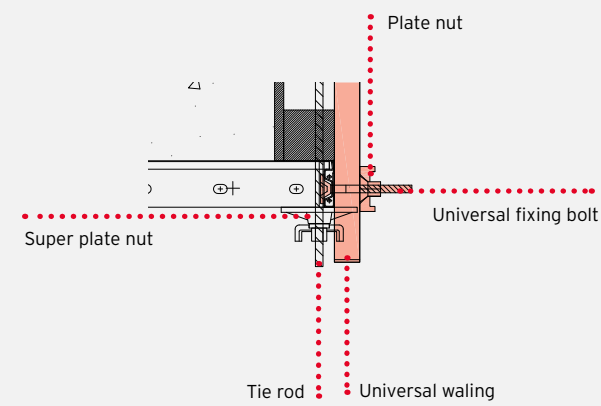

Stop end made using universal waling and universal fixing bolt.



STOP ENDS BY UNIVERSAL ELEMENT

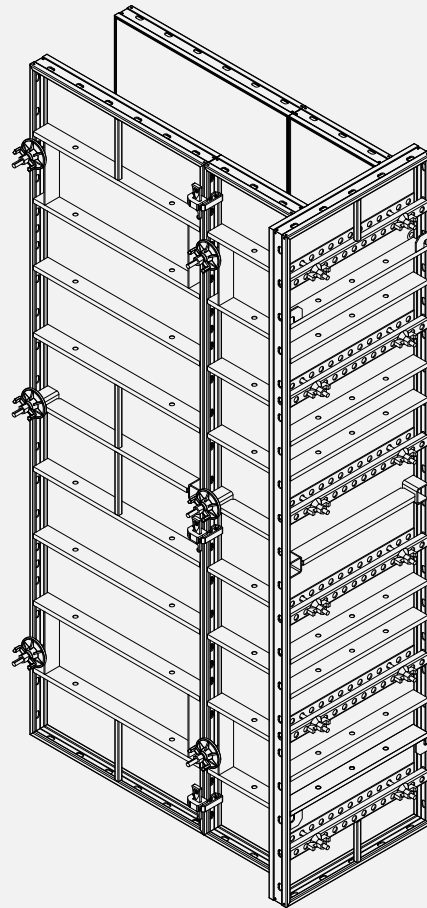

Stop end made using universal element

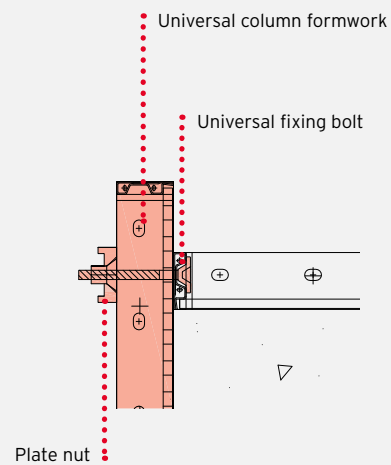
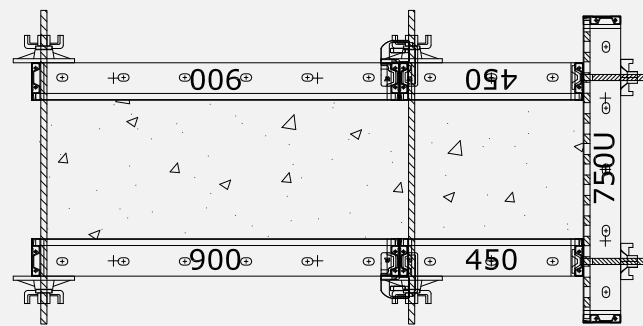

The universal element must be fixed to the standard elements by two universal fixing bolts for every multiholes profile

WALL OFFSET SOLUTION

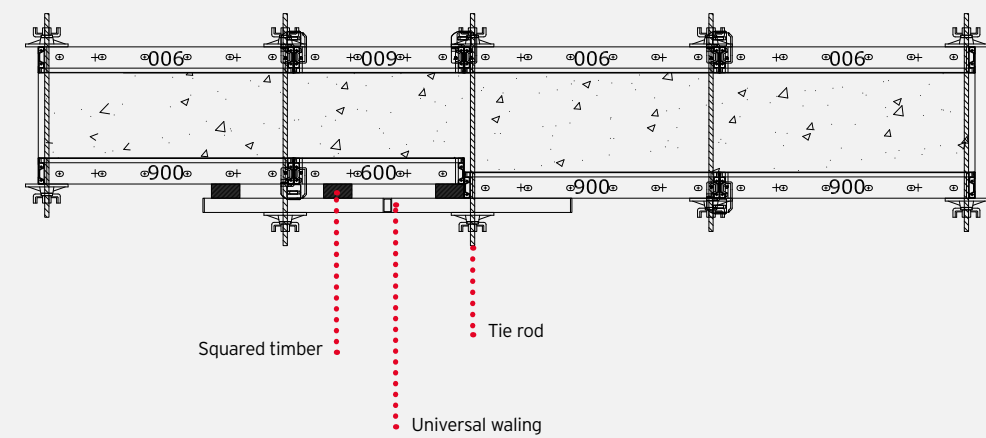
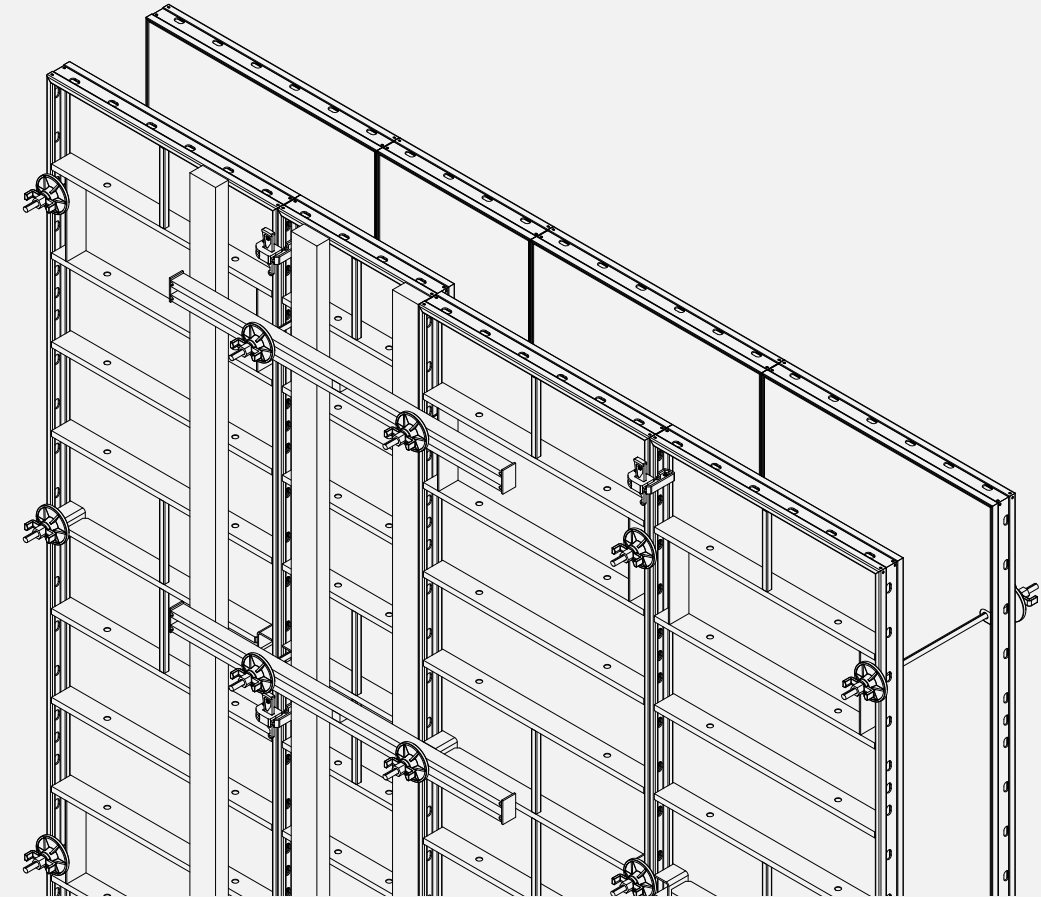

Example of formwork connection with variable wall thickness.

CONNECTION WITH EXISTING WALL

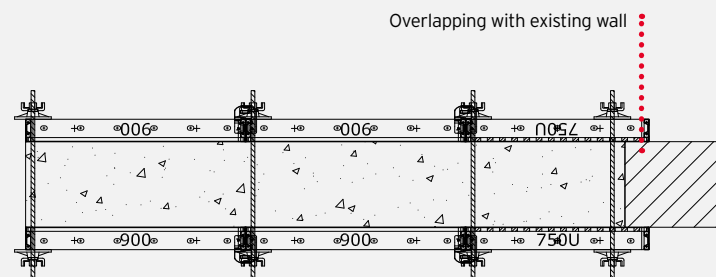
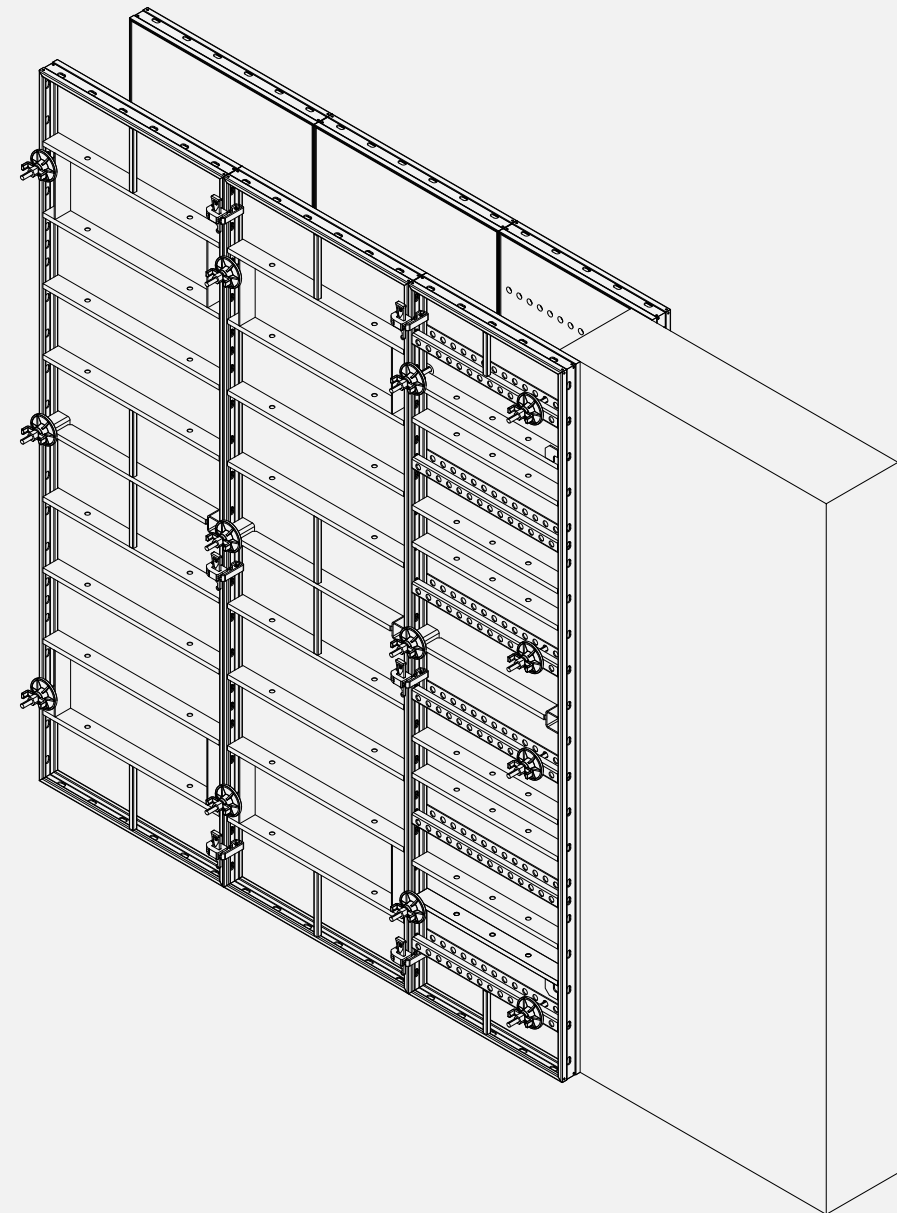

Example of formwork connection with existing wall

COLUMN FORMWORK

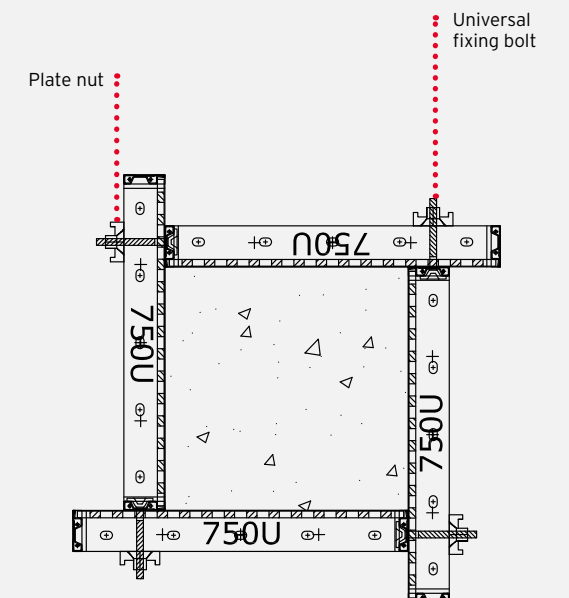
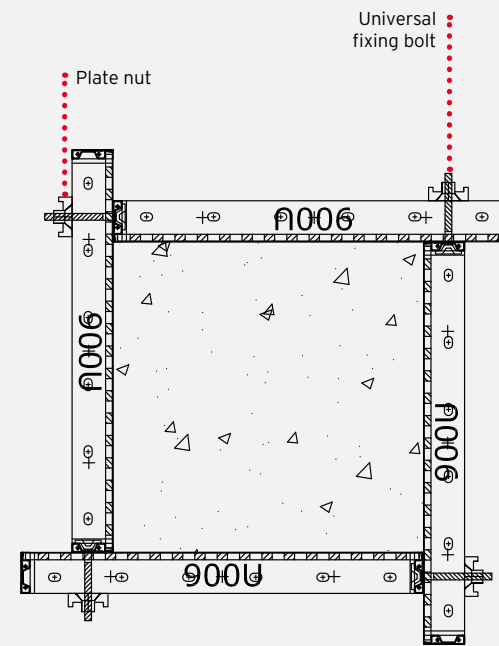
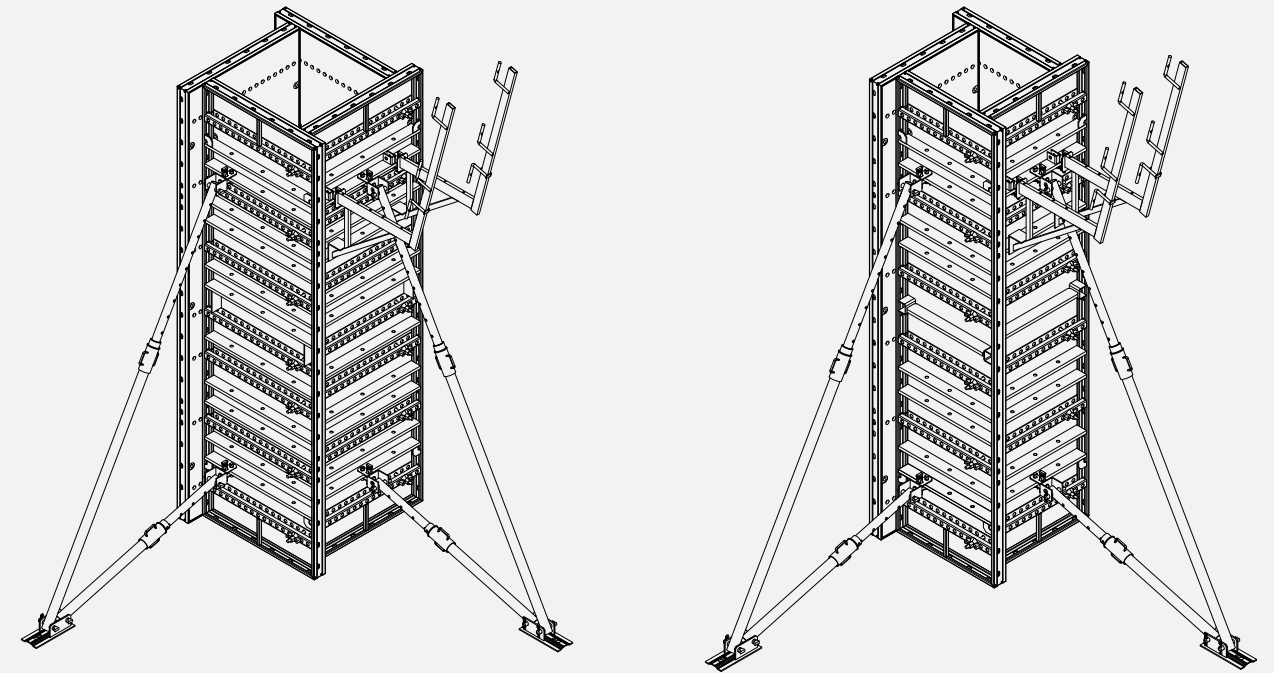

Even for universal elements for column, Destil Mini offers a wide range of possibilities. Universal elements are available in the following sizes: In height 3000/2700/1500/1200 mm and width 900 mm and 750 mm. They permit constructing columns of different dimensions, from 150 x 150 mm up to 800 x 800 mm using 900 mm panel and from 150 x 150 mm up to 650 x 650 mm using 750 mm panel. For fixing and anchoring the formwork elements use universal fixing bolt and plate nut.

FIXING DETAILS

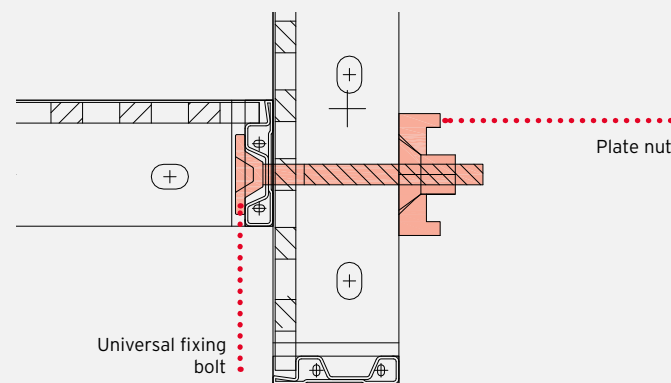
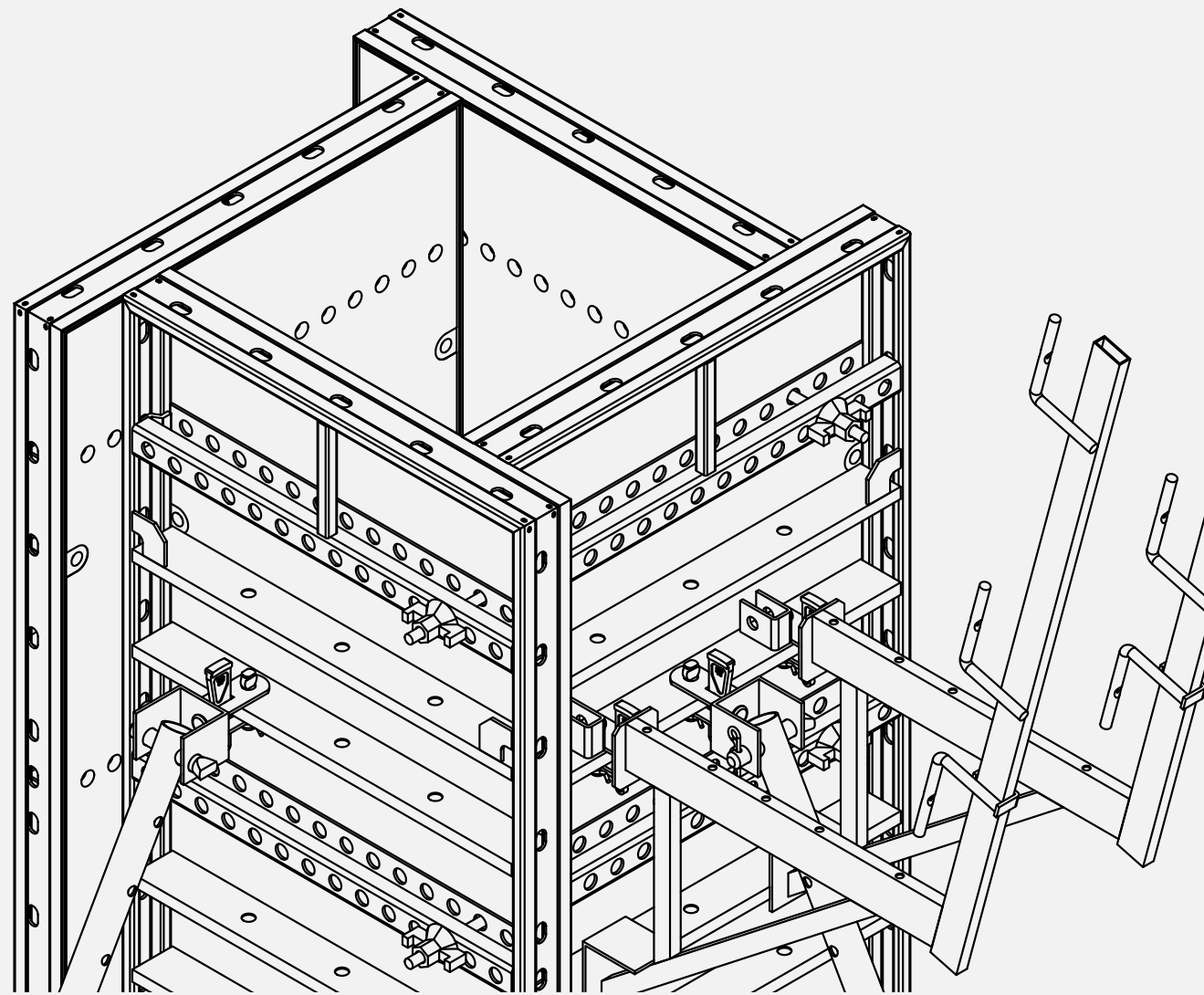

CIRCULAR FORMWORK

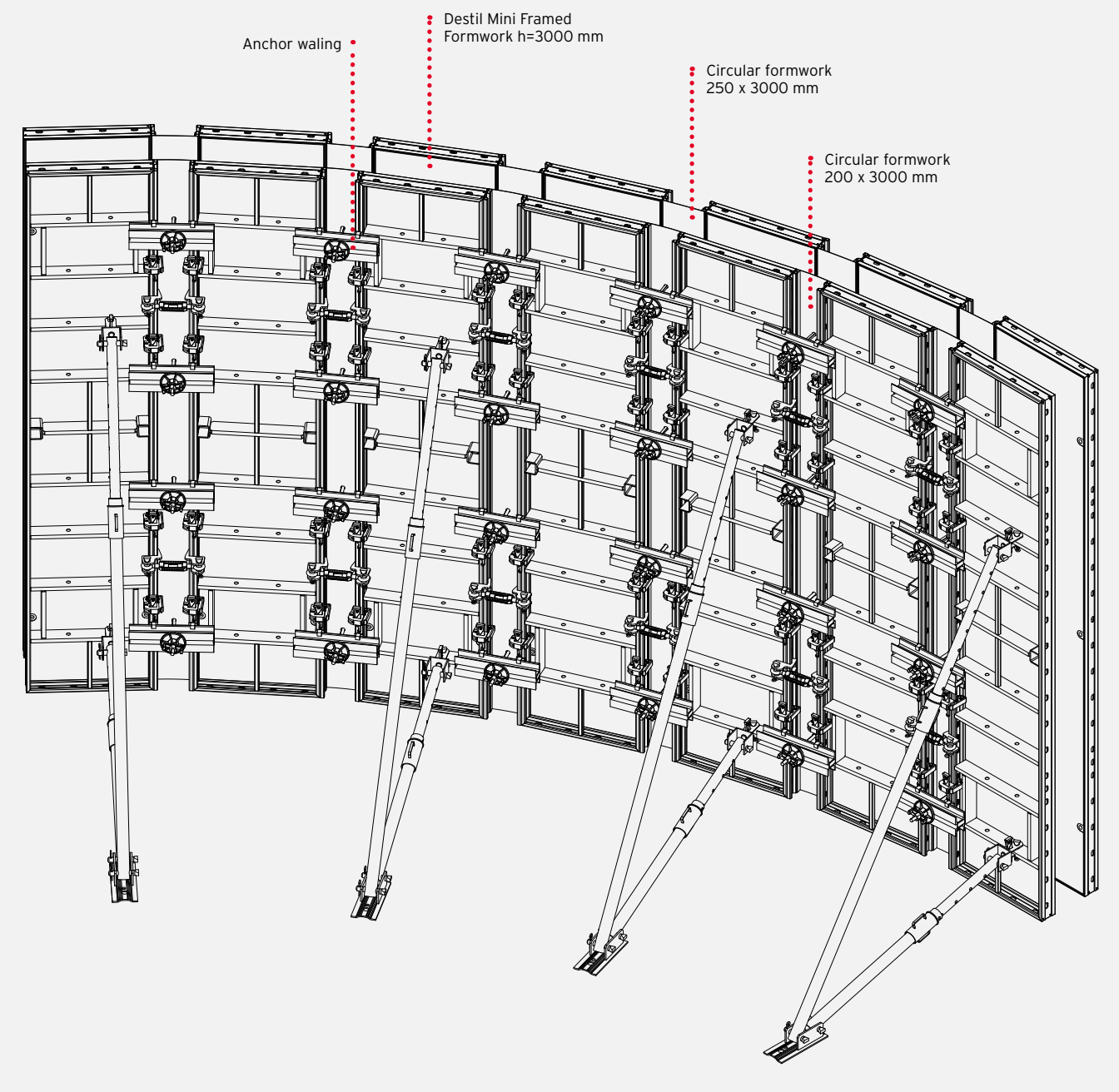

Destil Mini circular formworks are the universal, economical and fast solution for circular structure construction .  
 They are available :  
 - in two heights : H = 3000 mm and H = 1500 mm  
 - in two widths : L = 200 mm and L = 250 mm  
 They are used in combination with Destil Mini framed formworks to form round structures of any radius ( minimum inside radius = 1800 mm )  
 All Destil Mini accessories, for example scaffold brackets or panel struts can therefore be used; only quick acting clamps are necessary to connect circular formworks to Destil Mini framed formworks.



**CIRCULAR FORMWORK**

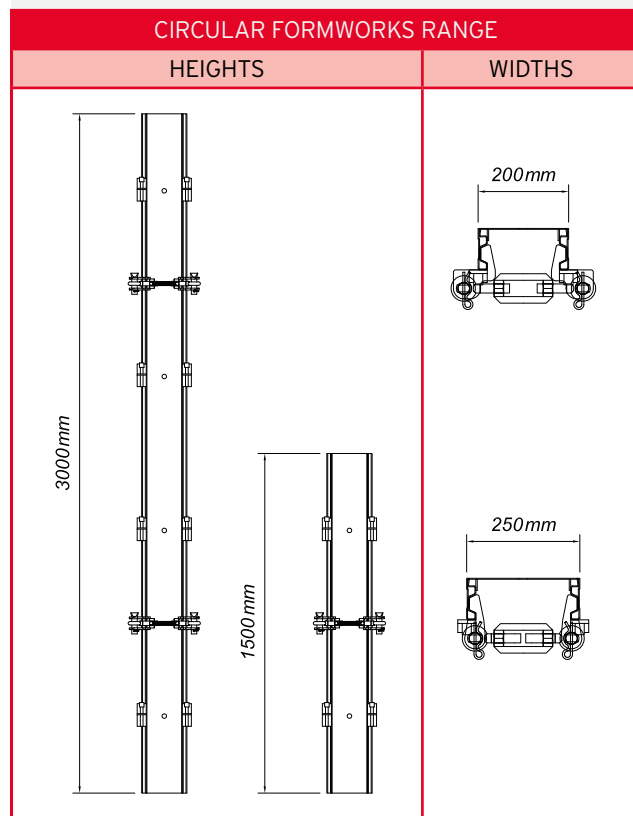

USING THE DIFFERENT WIDTHS OF CIRCULAR FORMWORKS :

- L = 200 mm**
  - Inside circular formwork
  - Outside circular formwork (for length adjustment)
- L = 250 mm**
  - Outside circular formwork

**TYING THE CIRCULAR FORMWORK :**

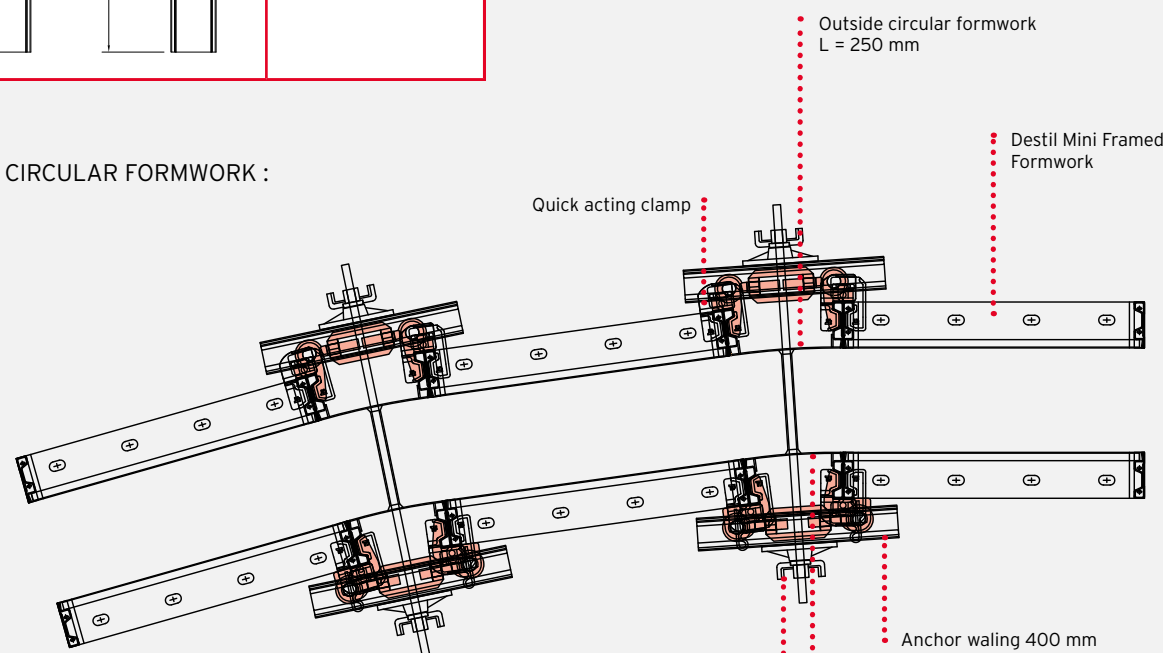

**ANCHOR WALING 400 mm DETAIL :**

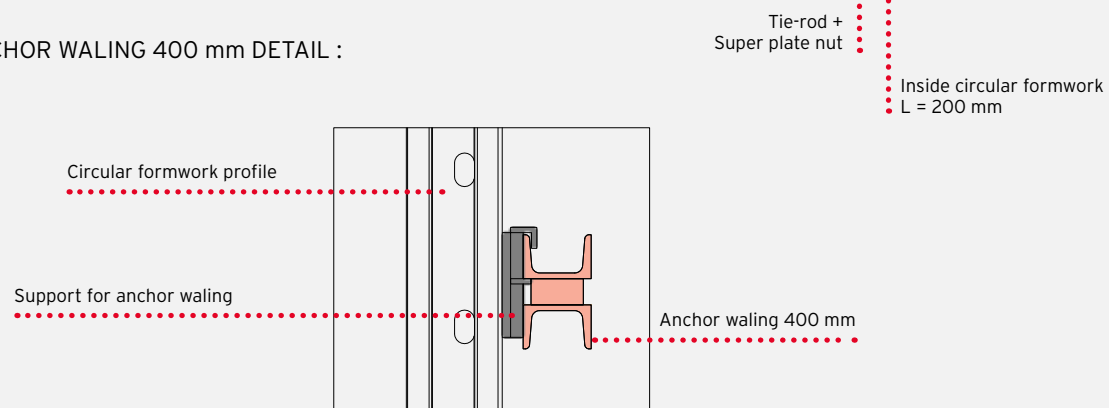

**SHAFT STRIPPING CORNER**

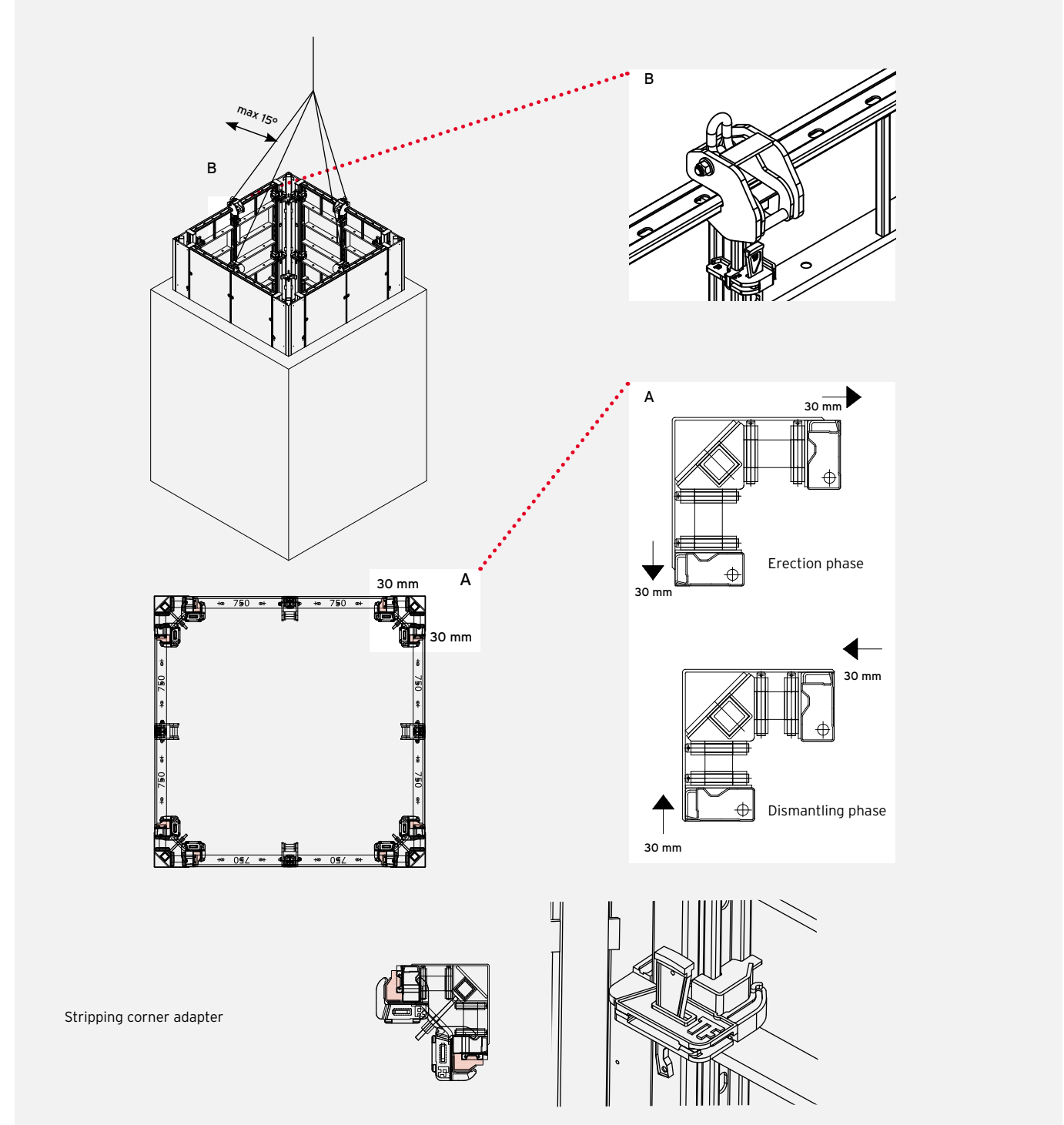

The Destil stripping corner for shaft permits to strip an entire shaft formwork and shift it at one time without dismantling every single element. Thanks to a special mechanism, the inner stripping corner allows the retraction of adjacent panels using a simple ratchet. Destil stripping corner can be coupled with Destil Mini Elements using the special Destil Mini Adaptor which will cover the gap between the different profiles thicknesses. After operating the retraction of the panels, the translation takes place in a simple, safe and quick manner, with Destil Mini lifting hooks and a four-rope lifting chain.

**LIFTING HOOK**

Lifting hook must be placed on perimetral profile.

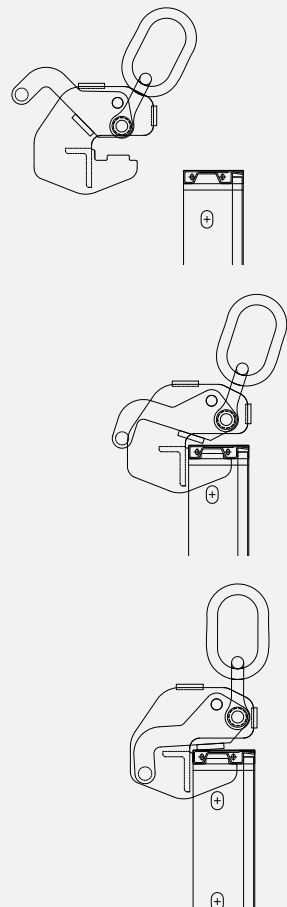
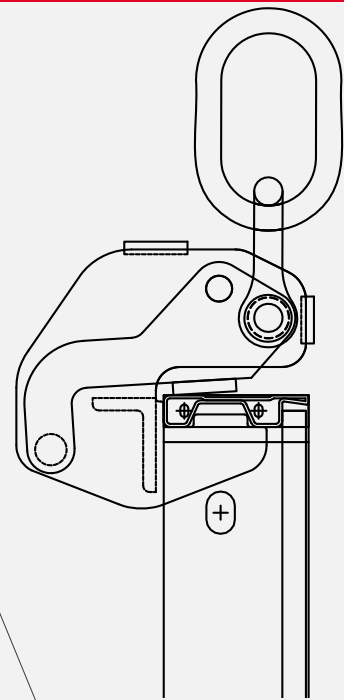
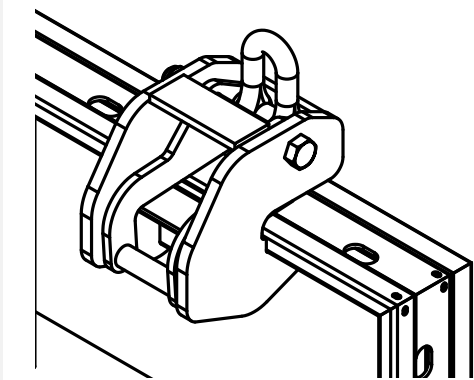

Lifting hook lock up system  
Lifting hook placement and lock-up sequence.

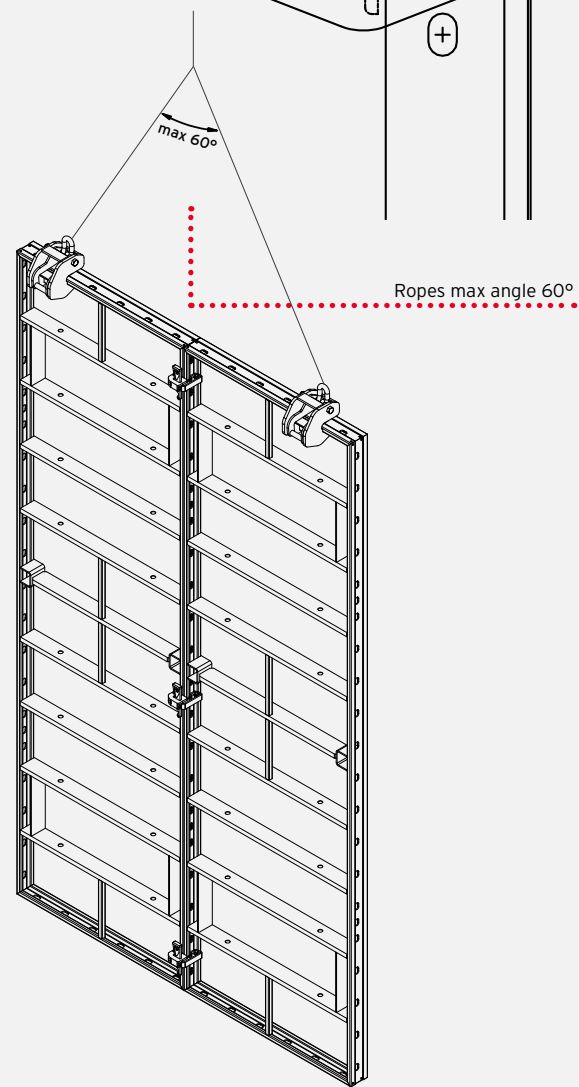

Code: CC0010DM - Weight: 12.5 Kg

Used for elements shifting. Must be hooked-up with appropriate chain ropes which must not create an angle greater than 60°. Each lifting hook has an admissible load of 1000 Kg. The lock system to the perimetral profile of the formwork is auto-locking. The lifting hook should be placed near the frame stiffenings.

**TRANSPORT AND STORAGE**

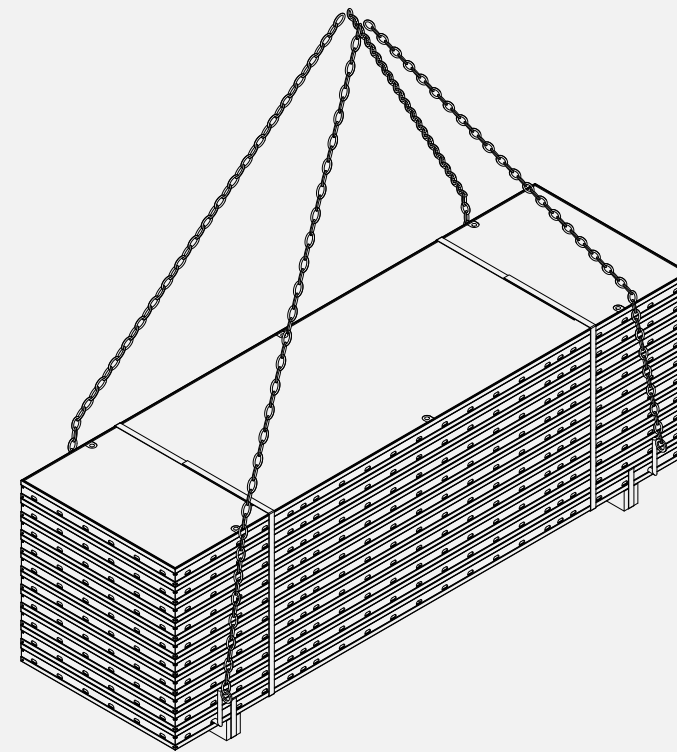

- 1) Place sleepers 80 x 100 mm under the cross-profile.
- 2) Strap the sleepers (squared timbers) and the bottom panel together with metal banding.
- 3) Stack up to 10 items.
- 4) tie the elements stack with straps.

**TRANSPORT AND STORAGE**

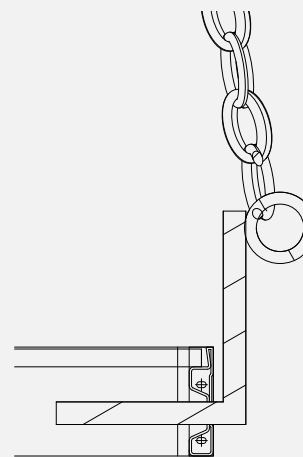

TRANSPORT BOLT  
Max capacity 500 kg (5 kN)  
Code: CC0104  
Weight: 1.90 Kg

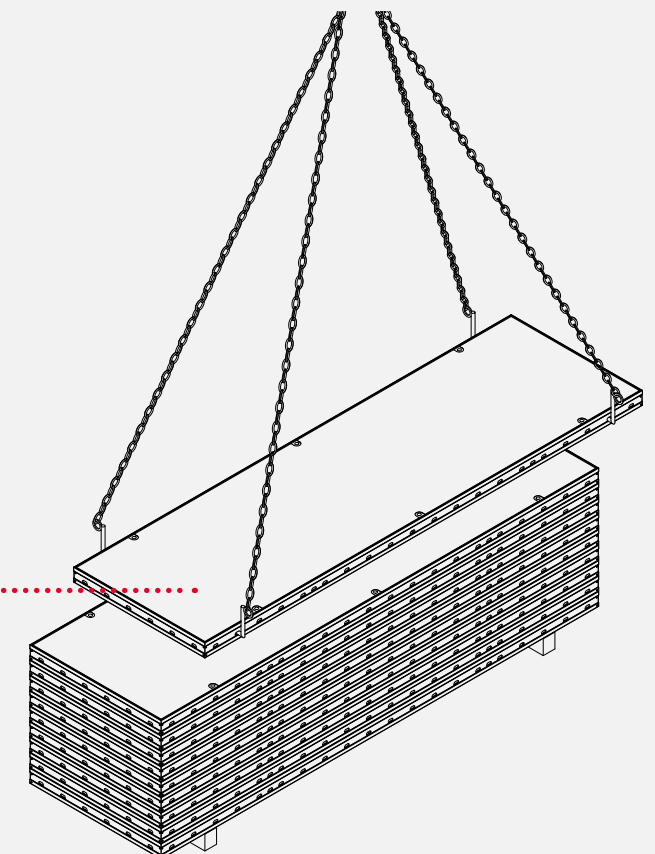

Transport bolt (capacity 5 kN), used together with the four rope chain, allowing the safe shifting of single items or entire bundles.

ITEMS LIST

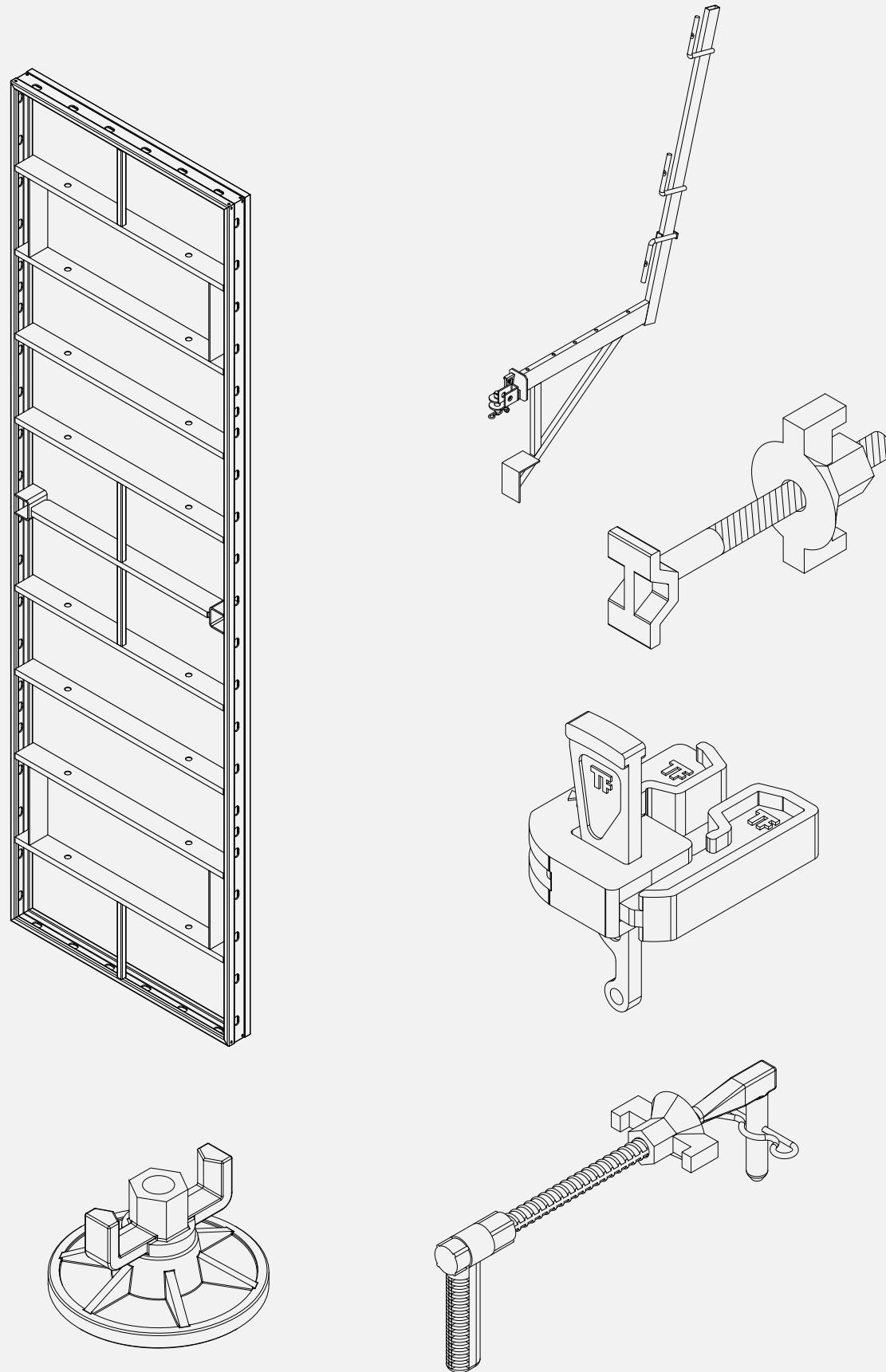

**DESTIL MINI 3000**

FORMWORK

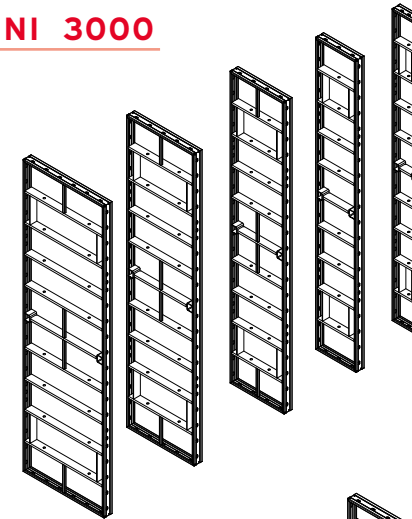

CODE	DESCRIPTION	WEIGHT (KG)
300090DM	3000 x 900	79.00
300075DM	3000 x 750	70.10
300060DM	3000 x 600	60.50
300045DM	3000 x 450	50.90
300030DM	3000 x 300	42.00

**DESTIL MINI 3000**

UNIVERSAL FORMWORK

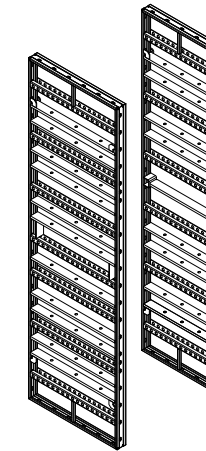

CODE	DESCRIPTION	WEIGHT (KG)
30009UDM	3000 x 900 UNIV.	113.60
30075UDM	3000 x 750 UNIV.	89.90

**DESTIL MINI 3000**

CORNERS

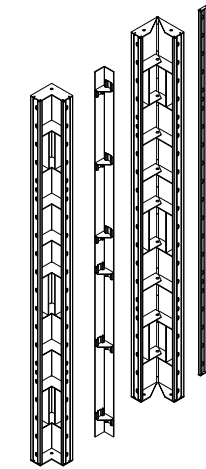

CODE	DESCRIPTION	WEIGHT (KG)
AIF300DM	Inside fixed corner H=3000	73.80
AEF300DM	Outside fixed corner H=3000	23.60
AIC300DM	Hinged inside corner H=3000	87.00
AEC300DM	Hinged outside corner H=3000	34.40

**DESTIL MINI 2700**

FORMWORK

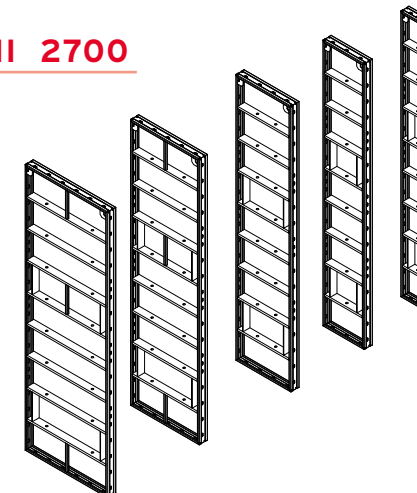

CODE	DESCRIPTION	WEIGHT (KG)
270090DM	2700 x 900	71.30
270075DM	2700 x 750	63.20
270060DM	2700 x 600	54.10
270045DM	2700 x 450	46.00
270030DM	2700 x 300	37.90



**DESTIL MINI 2700**

UNIVERSAL FORMWORK

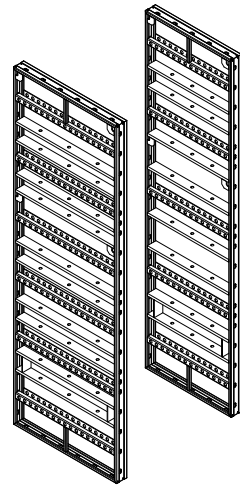

CODE	DESCRIPTION	WEIGHT (KG)
27009UDM	2700 x 900 UNIV.	101.70
27075UDM	2700 x 750 UNIV.	79.90

**DESTIL MINI 2700**

CORNERS

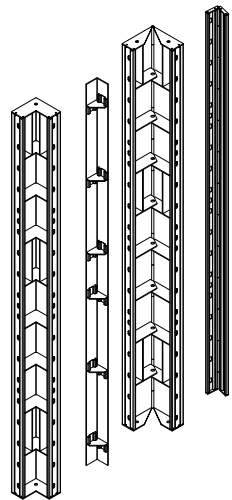

CODE	DESCRIPTION	WEIGHT (KG)
AIF270DM	Inside fixed corner H=2700	67.10
AEF270DM	Outside fixed corner H=2700	21.50
AIC270DM	Hinged inside corner H=2700	78.30
AEC270DM	Hinged outside corner H=2700	30.90

**DESTIL MINI 1500**

FORMWORK

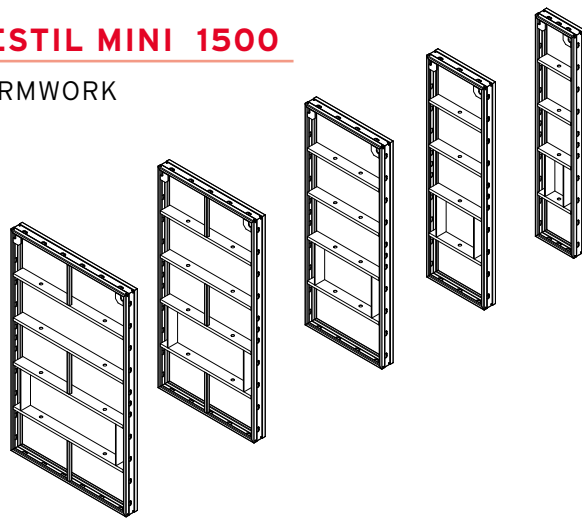

CODE	DESCRIPTION	WEIGHT (KG)
150090DM	1500 x 900	41.70
150075DM	1500 x 750	39.90
150060DM	1500 x 600	31.30
150045DM	1500 x 450	26.40
150030DM	1500 x 300	21.60

**DESTIL MINI 1500**

UNIVERSAL FORMWORK

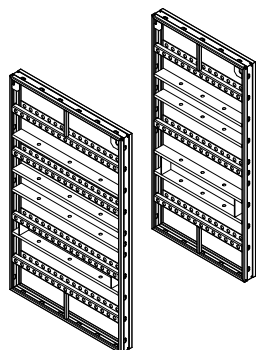

CODE	DESCRIPTION	WEIGHT (KG)
15009UDM	1500 x 900 UNIV.	59.60
15075UDM	1500 x 750 UNIV.	47.20

**DESTIL MINI 1500**

CORNERS

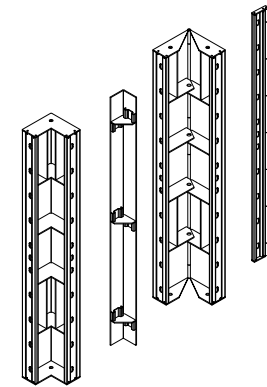

CODE	DESCRIPTION	WEIGHT (KG)
AIF150DM	Inside fixed corner H=1500	38.40
AEF150DM	Outside fixed corner H=1500	11.80
AIC150DM	Hinged inside corner H=1500	43.50
AEC150DM	Hinged outside corner H=1500	17.20

**DESTIL MINI 1200**

FORMWORK

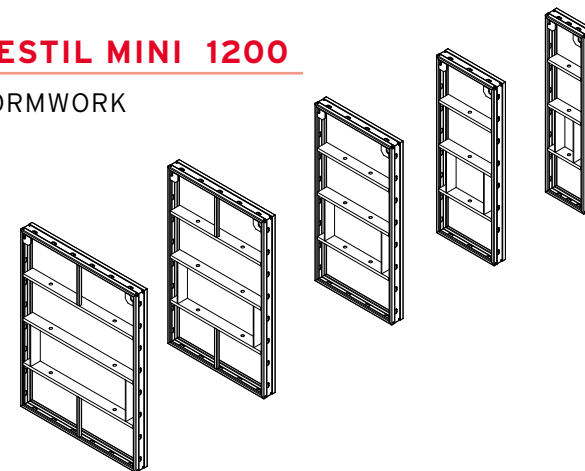

CODE	DESCRIPTION	WEIGHT (KG)
120090DM	1200 x 900	34.30
120075DM	1200 x 750	30.40
120060DM	1200 x 600	26.40
120045DM	1200 x 450	21.90
120030DM	1200 x 300	17.90

**DESTIL MINI 1200**

UNIVERSAL FORMWORK

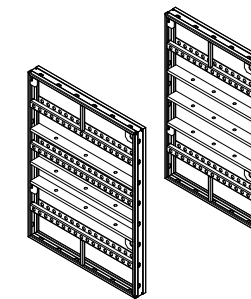

CODE	DESCRIPTION	WEIGHT (KG)
12009UDM	1200 x 900 UNIV.	46.90
12075UDM	1200 x 750 UNIV.	36.60

**DESTIL MINI 1200**

CORNERS

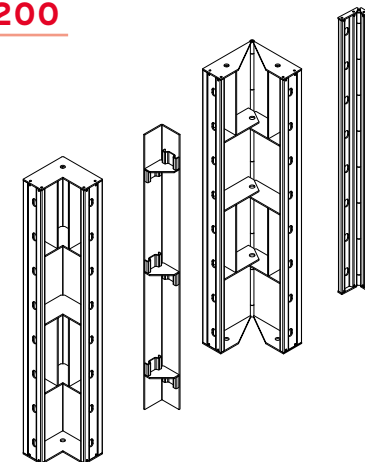

CODE	DESCRIPTION	WEIGHT (KG)
AIF120DM	Inside fixed corner H=1200	29.80
AEF120DM	Outside fixed corner H=1200	9.70
AIC120DM	Hinged inside corner H=1200	34.80
AEC120DM	Hinged outside corner H=1200	13.70

**DM ACCESSORIES**

QUICK ACTING CLAMP

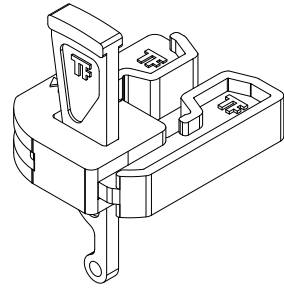

CODE	DESCRIPTION	WEIGHT (KG)
CC0008DM	Quick acting clamp	1.25

Used to connect adjoining formwork modules and may be placed at any point of border profile, possibly near the stiffeners.

**DM ACCESSORIES**

MULTI FUNCTION CLAMP

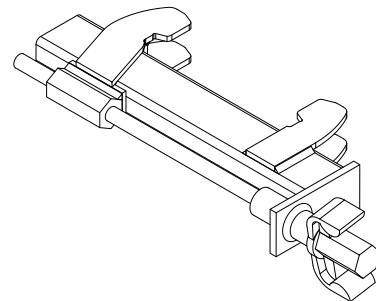

CODE	DESCRIPTION	WEIGHT (KG)
CC0009DM	Multi function clamp	4.30

Used to connect formwork modules and to allow compensations up to 150 mm width. May be placed at any point of border frames, preferably near the stiffenings.

**DM ACCESSORIES**

ALIGNING CLAMP

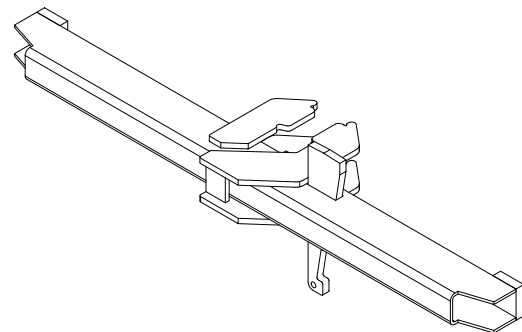

CODE	DESCRIPTION	WEIGHT (KG)
CC0013DM	Aligning clamp	3.20

Placed directly over the cross profile during overlapping it provides an additional reinforcement in the formwork modules connection

**DM ACCESSORIES**

UNIVERSAL FIXING BOLT

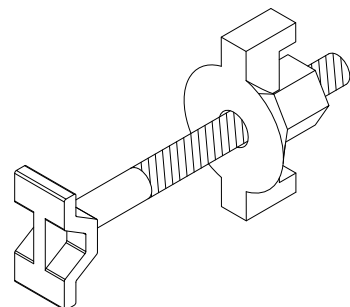

CODE	DESCRIPTION	WEIGHT (KG)
CC0019DM	Universal fixing bolt 160 + Plate nut ø60mm	1.10
CC0050DM	Universal fixing bolt 330 + Plate nut ø60mm	1.50

Ties up universal module formwork, 900 and 750 mm, with any other standard module in for columns and external corners.

**DM ACCESSORIES**

SUPER PLATE NUT DW15

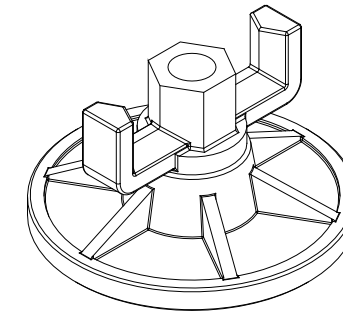

CODE	DESCRIPTION	WEIGHT (KG)
CC001	Super plate nut DW15 (ø120/130)	1.30

Screwed on the tie rods in order to lock up bindings (2 plates needed for each bar). Admissible load =90 kN (according to regulation DIN 18216).

**DM ACCESSORIES**

PLATE NUT DW15

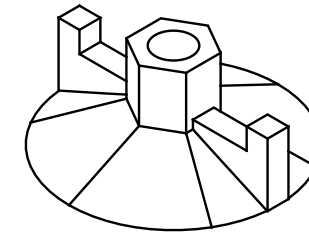

CODE	DESCRIPTION	WEIGHT (KG)
CC0002	Plate nut DW15 (ø110)	0.70
CC0046	Plate nut DW15 (ø130)	1.25
CC0003	Plate nut DW15 (ø60)	0.60

Used to fix and lock up the Universal fixing bolt.

**DM ACCESSORIES**

TIE ROD DW15

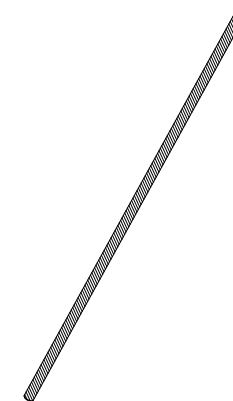

CODE	DESCRIPTION	WEIGHT (KG)
CC0070	Tie rod (L=600 cm)	8.70

The bars can be reused; but prior to casting, they should be put in plastic tube, type 22/26. For correct usage the bar should be equipped with appropriate accessories (Super plate nuts or Hexagon nuts or Plate nuts D15).

Admissible load: 90 kN (according to regulation DIN 18216)

Ultimate load: 190 kN (according to regulation DIN 18216)

NOTE: To avoid rupture or deformations, the bars should not be warmed-up or welded.

**DM ACCESSORIES**

UNIVERSAL WALING

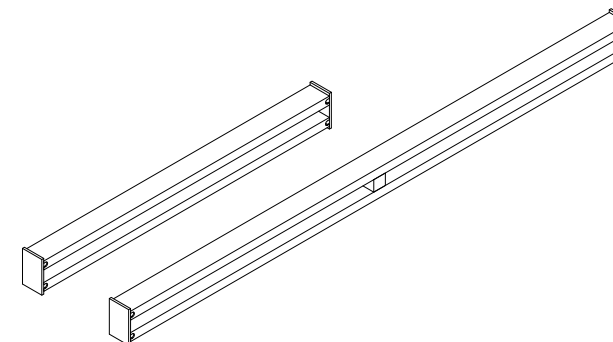

CODE	DESCRIPTION	WEIGHT (KG)
CC0011DM	Universal waling L=750 mm	3.4
CC0012DM	Universal waling L=1300 mm	5.7

Produced in two sizes and can be used in compensation areas and/or to rigidify the overlapped formworks. Fixed to the formwork with two Universal fixing bolts for waling.

**DM ACCESSORIES**

UNIVERSAL FIXING DEVICE FOR WALING

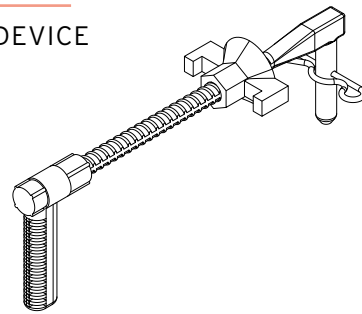

CODE	DESCRIPTION	WEIGHT (KG)
CC0017DM	Universal fixing device for waling	1.30

Fixes Universal waling and modules of frame formworks; can be joined with trasversal profile.

**DM ACCESSORIES**

ANCHOR BRACKET

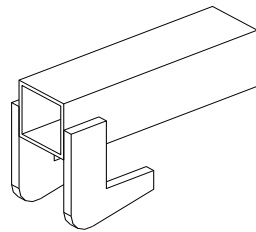

CODE	DESCRIPTION	WEIGHT (KG)
CC0024DM	Anchor bracket	0.30

Enables placement of tie rods above the profile edge in any position.

**DM ACCESSORIES**

HEXAGONAL NUT DW15

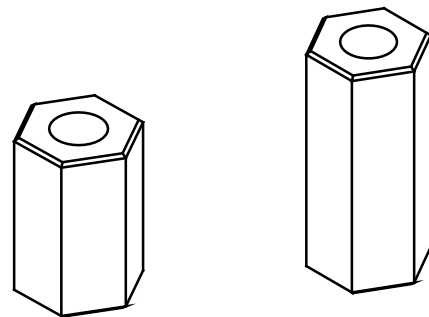

CODE	DESCRIPTION	WEIGHT (KG)
CC0004	Hexagonal nut DW15 (L=50 mm)	0.30
CC0005	Hexagonal nut DW15 (L=70 mm)	0.32

Code: CC0004 | Weight: 0.30 Kg  
Used to replace the Super plate nut in hard-to-reach places; in this case it's completed with pressure plate. Admissible load: 90 kN (according to regulation DIN 18216).

Code: CC0005 | Weight: 0.32 Kg  
Used with Universal fixing bolt (L=205), Universal fixing bolt (L=330) and Universal angle tie bracket. Can be used as an alternative to Plate nuts in hard-to-reach places. Admissible load: 90 kN (according to regulation DIN 18216).

**DM ACCESSORIES**

PRESSURE PLATE

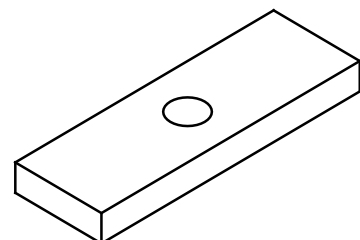

CODE	DESCRIPTION	WEIGHT (KG)
CC0015	Pressure plate	0.80

Used with Hexagon nut to tie down horizontally-oriented formwork; for execution of casting operations of limited height (about 120 cm high).

**DM ACCESSORIES**

STRIPPING CORNER ADAPTER

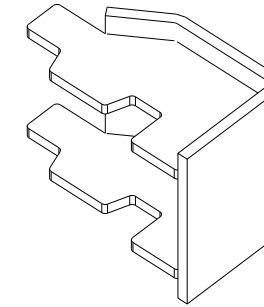

CODE	DESCRIPTION	WEIGHT (KG)
CC0028DM	Stripping corner adapter	0.70

Used with Destil Stripping Corner in order to re-align the profiles with different thickness

**DM ACCESSORIES**

CLOSURE SHEETS

MADE TO ORDER

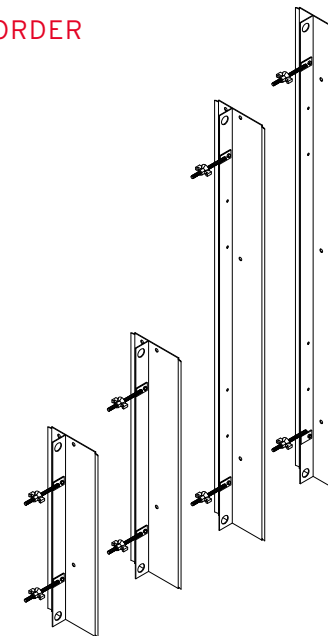

CODE	DESCRIPTION	WEIGHT (KG)
CC0006DM	Closure sheet H=1200	23.50
CC0039DM	Closure sheet H=1500	25.50
CC0040DM	Closure sheet H=2700	46.50
CC0007DM	Closure sheet H=3000	51.50

Allows adjusting the formwork module measures from 10 to 300 mm and also enables easier removing operations in closed spaces.

Used in conjunction with Universal waling to which it must be fixed. The compensation sheet has appropriate holes planned for the tie rod's passage

**DM ACCESSORIES**

STEEL CLOSURE

MADE TO ORDER

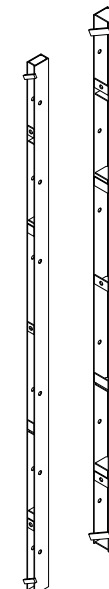

CODE	DESCRIPTION	WEIGHT (KG)
CC0109DM	Steel closure 50x3000	22.00
CC0110DM	Steel closure 100x3000	28.00

Steel closures, available in two widths 50 mm and 100 mm, are used mainly where there is the need for a closure in corner zones.

Thanks to tie-rods through holes, no universal walings are needed



**DM ACCESSORIES**

CIRCULAR FORMWORKS

MADE TO ORDER

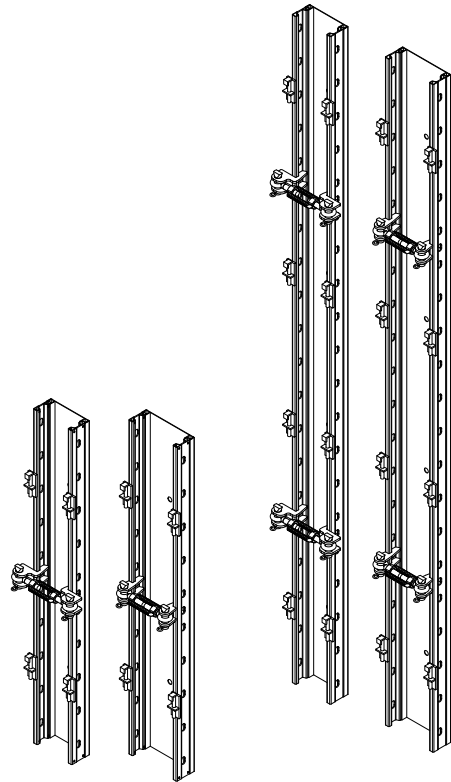

CODE	DESCRIPTION	WEIGHT (KG)
CC011DM	Circular formwork 200 x 3000	45.00
CC012DM	Circular formwork 250 x 3000	47.00
CC014DM	Circular formwork 200 x 1500	22.50
CC015DM	Circular formwork 250 x 1500	23.50

Destil Mini circular formworks are the universal, economical and fast solution for circular structure construction. They are available :

- in two heights : H = 3000 mm and H = 1500 mm
- in two widths : L = 200 mm and L = 250 mm

They are used in combination with Destil Mini framed formworks to form round structures of any radius ( minimum inside radius = 1800 mm )

**DM ACCESSORIES**

ANCHOR WALING 400 mm

MADE TO ORDER

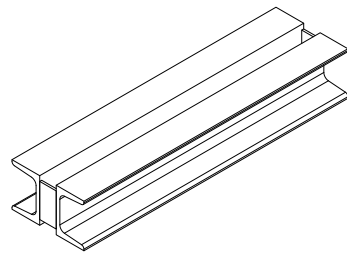

CODE	DESCRIPTION	WEIGHT (KG)
CC016DM	Anchor waling 400 mm	6.00

Used, in combination with tie-rod and super plate nut, for tying the circular formworks. It's supported on special hooks provided on circular formworks profiles

**DM ACCESSORIES**

LIFTING HOOK

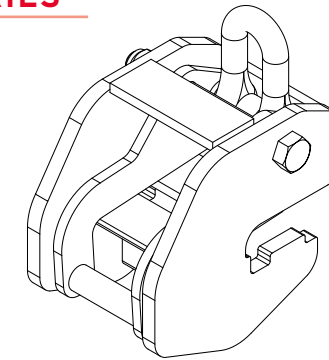

CODE	DESCRIPTION	WEIGHT (KG)
CC0010DM	Lifting hook	7.53

Used for lifting modules. Must be hooked-up with appropriate chain ropes which must not form an angle greater than 60°. Each lifting hook has an admissible load of 1000 Kg. The lock system to the border profile of the formwork is auto-lock up. The lifting hook should be placed near the frame stiffenings.

**DM ACCESSORIES**

SCAFFOLD BRACKET |  
WALKWAY BRACKET

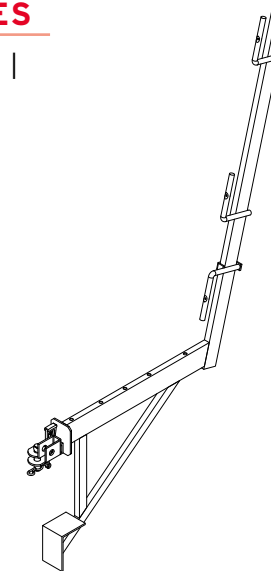

CODE	DESCRIPTION	WEIGHT (KG)
CC0022DM	Scaffold Bracket	7.80

Should be used for construction of casting platforms or service platforms. Fixed bracket is joined to the formwork structure with appropriate fixing head. It is recommended to maintain the distance between two brackets not greater than 1.8 metres. The work platforms should have timber board in the bottom, in the middle and on the top of the vertical handrail structure; and the distance shouldn't be larger than 600 mm.

**DM ACCESSORIES**

PANEL STRUT |  
PUSH / PULL PROP

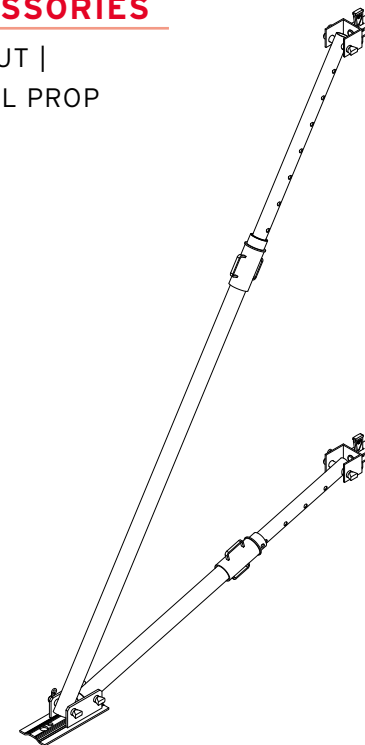

CODE	DESCRIPTION	WEIGHT (KG)
CC0025DM	Panel strut L=3400 mm	36.30

Panel strut allows the adjustment of formwork perfectly vertical and can reach up to 4.5 metres height. Has two telescopic arms; each of which has one Prop head which is suitable for anchorage to formwork at any point. The Prop shoe should be fixed to the ground in order to avoid turnover of the formwork.



**DM ACCESSORIES**

PANEL STRUT LONG BRACE |  
LONG PUSH / PULL PROP

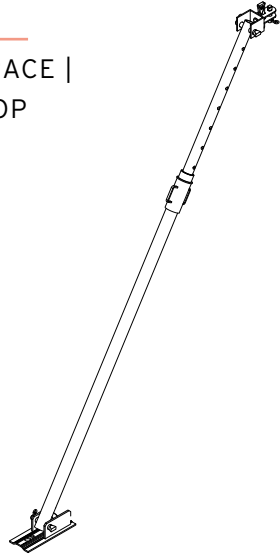

CODE	DESCRIPTION	WEIGHT (KG)
CC0036DM	Panel strut long brace L=3400 mm	21.26

**DM ACCESSORIES**

PANEL STRUT SHORT BRACE |  
SHORT PUSH / PULL PROP

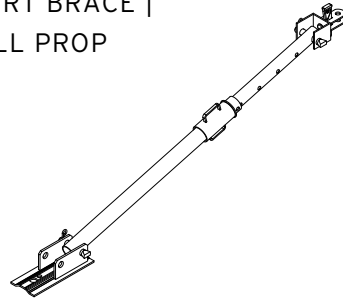

CODE	DESCRIPTION	WEIGHT (KG)
CC0035DM	Panel strut short brace L=1500 mm	13.86







**FOWLER**  
SCAFFOLD HOISTS FORMWORK

UNIDECK

ALLUMINIUM PANEL  
SLAB FORMWORK



## OUR COMPANY...

Based on thirty years experience as a producer. Our company produces technological equipment for the building industry.

Engineering, design and testing are at the basis of every project carried out by our company.

Choice of quality materials, in-house production and rigorous testing operations are the prerogatives for our high quality products.

### FORMWORK FOR CLOSED PANEL SLAB

Studied for the most demanding construction sites, where velocity, firmness, flexibility and technology must be a whole with the product.

The technicians realised a high quality product, able to respond to the multiple needs of the modern construction site.

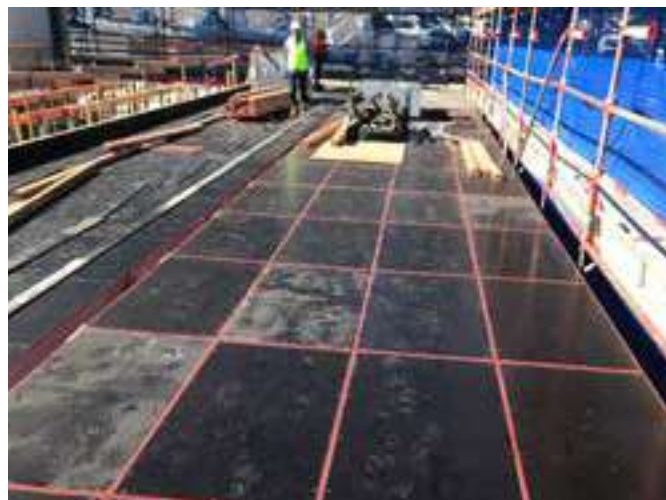

### SYSTEM COMPONENTS

We decided to keep faith to its technological commitment, producing a single combined system for the fulfilment of every type of slab; for this reason the UNIDECK panel integrates perfectly with the Lajflex system and all its accessories, allowing the technological growth of its customers without a continuous replacement of the components.



Lowering head



Alu beam



PVC Profile



UNIDECK closed panel 750 x 1500 mm

UNIDECK closed panel 420 x 1500 mm

UNIDECK closed panel 375 x 1500 mm

UNIDECK closed panel 750 x 750 mm

UNIDECK closed panel 420 x 750 mm

UNIDECK closed panel 375 x 750 mm



**ADVANTAGES OF THE UNIDECK SYSTEM**

**1**

**Easy to assemble**

A few simple procedures allows the assembly of the 3 main elements of the system.

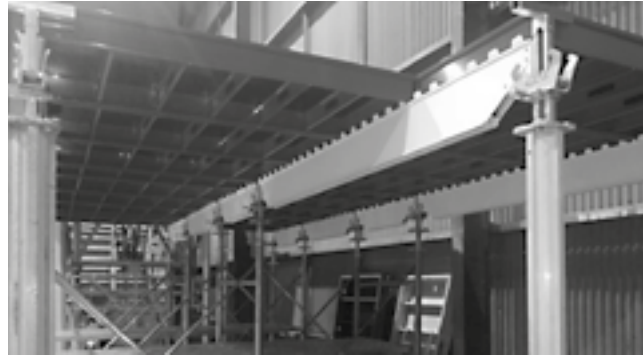

**2**

**Fast to assemble**

Our system is based on simple concepts, result quick in its purpose; so the laying results are fast and safe.



**3**

**Flexibility**

Being flexibility the primary feature of the system, the formwork fully integrates with the previous systems and with the most demanding construction types.



**4**

**Safe**

Integrating with the other systems, the workers have all the accessories to secure the working area simply and quickly.



**ASSEMBLY AND DISMANTLE OF THE UNIDECK SYSTEM**

Props, main beams and UNIDECK panel placement

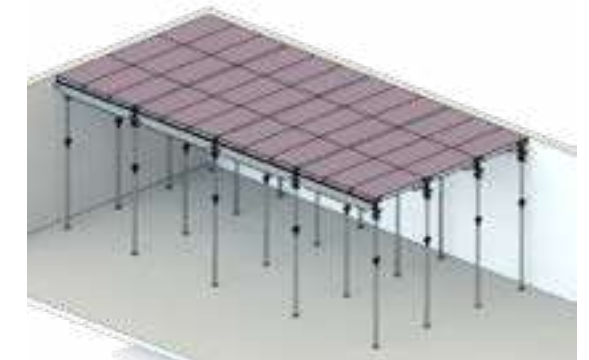

**ASSEMBLY AND DISMANTLE OF THE UNIDECK STRUCTURE**

**Striking**

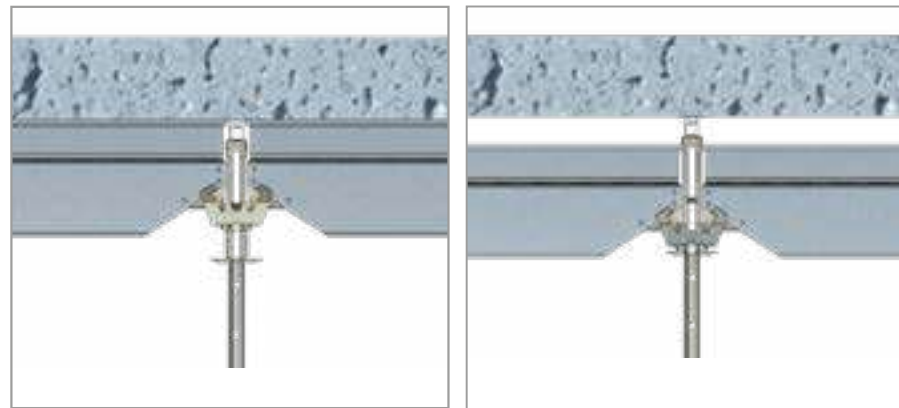

**PROP LOADS WITH DROPHEAD UNIDECK**



PANEL SPAN 1,50 MT							
Slab thickness D mm	Load Q (kN/m <sup>2</sup> )	Prop load kN * Main beam UDK 155	Deflection line **	Prop load kN * Main beam UDK 230	Deflection line **	Prop load kN * Main beam UDK 305	Deflection line **
100	4.30	10.00	7	14.84	7	19.67	7
120	4.82	11.21	7	16.63	7	22.05	7
140	5.34	12.42	7	18.42	7	24.43	7
160	5.86	13.62	7	20.22	7	26.81	6
180	6.38	14.83	7	22.01	7	29.19	6
200	6.90	16.04	7	23.81	7	31.57	5
250	8.20	19.07	7	28.29	7	37.52	5
300	9.56	22.23	7	32.98	6		
350	11.12	25.85	6	38.36	6		
400	12.68	29.48	6	43.75	5		
450	14.24	33.11	6				
500	15.80	36.74	6				
550	17.36	40.36	6				

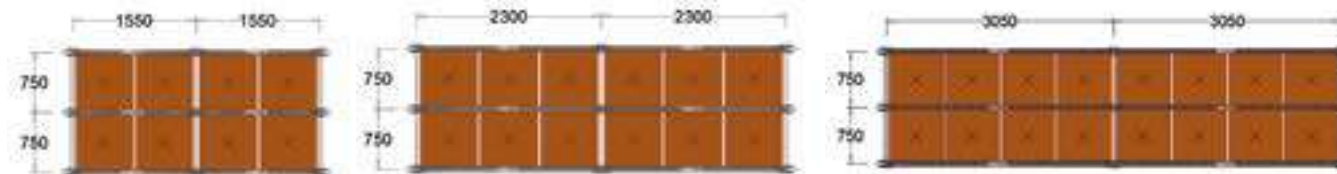

PANEL SPAN 0,75 MT							
Slab thickness D mm	Load Q (kN/m <sup>2</sup> )	Prop load kN * Main beam UDK 155	Deflection line **	Prop load kN * Main beam UDK 230	Deflection line **	Prop load kN * Main beam UDK 305	Deflection line **
100	4.30	5.00	7	7.42	7	9.84	
120	4.82	5.60	7	8.31	7	11.03	7
140	5.34	6.21	7	9.21	7	12.22	7
160	5.86	6.81	7	10.11	7	13.40	7
180	6.38	7.42	7	11.01	7	14.59	7
200	6.90	8.02	7	11.90	7	15.78	7
250	8.20	9.53	7	14.15	7	18.76	7
300	9.56	11.11	7	16.49	7	21.87	6
350	11.12	12.93	7	19.18	7	25.44	6
400	12.68	14.74	7	21.87	6	29.01	6
450	14.24	16.55	7	24.56	6		6
500	15.80	18.37	7	27.26	6		
550	17.36	20.18	7	29.95	6		
600	18.92	21.99	7				
650	20.48	23.81	6				
700	22.04	25.62	6				
750	23.60	27.44	6				
800	25.16	29.25	6				

\*Load according to DIN EN 4421:  
 Dead load Q1 = 0.20 kN/m<sup>2</sup>  
 Concrete load Q2 = 0.26 kN/m<sup>3</sup> x D (mm)  
 Variable load Qv = 0.2 x Q2 + 1,50 kN/m<sup>2</sup>

Total load Q = Q1 + Q2 + Qv  
 \*\*Deflection according to DIN 18202



## UNIDECK Main Components

Code 700-2024  
**LOWERING HEAD**  
 Main element of the system.  
 Quick release wedge for fast stripping, fits standard prop allows install of beam from bottom.  
 Weight: 7.55 kg  
 Finishing: hot dip galvanized



Code 700-2027  
**FIX HEAD**  
 Main alu beam element, center distance 305 cm  
 Weight: 2.3 kg (L305)  
 Finish: polyester painting / electrolytic galvanized.



Code 700-2028  
**FIXED SUPPORT**  
 Anchoring element with lower screw for beam-prop.  
 Weight: 2.60 kg  
 Finish: electrolytic galvanized



Code 700-2001  
**ALU BEAM L3050**  
 Main element of the system.  
 Weight: 24 kg  
 Finish: hot galvanized



Code 700-2000  
**ALU BEAM L2225**  
 2225 mm long  
 Weight: 18.00 kg  
 Finish: polyester painting / electrolytic galvanized.



Code 700-2002  
**ALU BEAM L1550**  
 1550 mm long  
 Weight: 12.00 kg  
 Finish: polyester painting / electrolytic galvanized.



Code 700-2003  
**ALU BEAM L1220**  
 1220 mm long  
 Weight: 9.50 kg  
 Finish: polyester painting / electrolytic galvanized



Code 700-2010  
**UNIDECK PANEL 750 x 1500 mm**  
 Fitted with multilayer panel H 9  
 Weight: 16.00 kg  
 Finish: polyester painting



Code 700-2012  
**UNIDECK PANEL 420 x 1500 mm**  
 Fitted with multilayer panel H 9  
 Weight: 12.00 kg  
 Finish: polyester painting



Code 700-2011  
**UNIDECK PANEL 375 x 1500 mm**  
 Fitted with multilayer panel H 9  
 Weight: 10.00 kg  
 Finishing: polyester painting



Code 700-2015  
**UNIDECK PANEL 750 x 750 mm**  
 Fitted with multilayer panel H 9  
 Weight: 9.00 kg  
 Finishing: polyester painting



Code 700-2017  
**UNIDECK PANEL 420 x 750 mm**  
 Fitted with multilayer panel H 9  
 Weight: 6.50 kg  
 Finish: polyester painting



Code 700-2016  
**UNIDECK PANEL 375 x 750 mm**  
 Fitted with multilayer panel H 9  
 Weight: 5.50 kg  
 Finish: polyester painting



Code 700-2050  
**PVC PROFILE L1500**  
 Element for the complete system.  
 Weight: 1.50 kg  
 Finish: pvc



Code 700-2041/2040  
**FE COMPENSATION L75 / L150**  
 Compensation element for decking. 750 mm and 1500mm  
 Weight: 5.00 / 10.00 kg  
 Finish: electrolytic galvanized



Code 700-2063  
**END SUPPORT**  
 Terminal element of the system  
 Weight: 1.20 kg  
 Finish: electrolytic galvanized



Code 700-2055  
**WALL FIXING**  
 Element for anchoring the system to the wall  
 Weight: 11.00 kg  
 Finish: electrolytic galvanized



Code 700-2082  
**BOX FOR PANELS**  
 Weight: 70.00 kg  
 Finish: polyester painting



Code PK-BMT.A02  
**PLATFORM FOR PANELS**  
 Weight: 90.00 kg  
 Finish: polyester painting

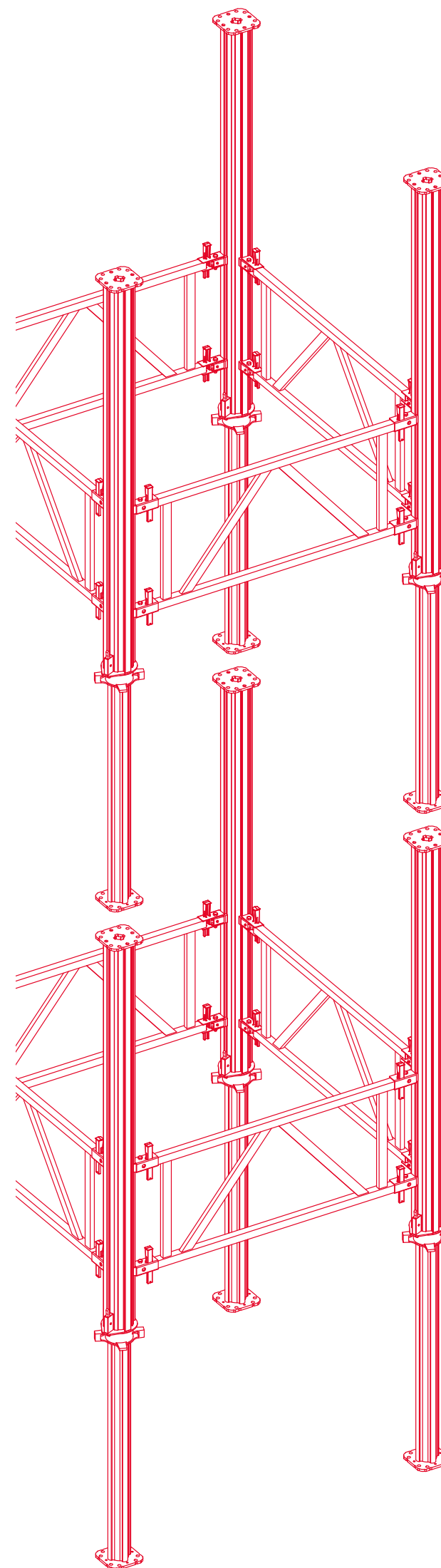

# FOWLER

SCAFFOLD HOISTS FORMWORK

## ALU PROP

USER INFORMATION



## SUMMARY

FEATURES	127
SYSTEM COMPONENTS	128
ACCESSORIES	129
ELEMENTS TECHNICAL FEATURES	130
ASSEMBLING INSTRUCTIONS	132
HORIZONTAL ASSEMBLY	134
VERTICAL ASSEMBLY	136
TUBE & COUPLERS BRACING	137
TRANSPORT & STORAGE	137
ITEMS LIST	138

## FEAUTRES

**ALU-PROPS:** Are a versatile light weight prop with an excellent heavy-duty load capacity, ideal for back propping heavy slabs and structures, combined with connecting frames, which stiffens and stabilises props further, increasing the props load capability further. Using Alu-Prop Towers is ideal to form or back prop high strutting cast in-situ slabs and structures.

**STANDARD MODULARITY:** System modularity is provided by the connecting frames, available in a wide range of sizes, defining the prop spans to suit the load-ability required by the props. As for the vertical modularity, the Alu-Props are connected end to end, to reach the height required.

**HIGH WORKING LOADS:** With appropriate planning, the heavy duty Alu-Props with the correct length connecting frames and positioning of Alu-Props will ensure the systems load-ability to support the load of the structure. No fixed load data is provided within this user information guide, given the large range of variables in propping combinations available. Contact Fowler for applicable load charts to suit your project.

**EASY TO USE:** With very few accessories required to form Alu-Prop towers, the system is very easy to use and can be safely erected and dismantled using the appropriate decks and methodology.

**EASY SHIFTING:** Dedicated devices, such as heavy-duty wheels, lifting forks and straps offer a safe, fast solution for the shifting and recycling Alu-Towers

**SAFETY:** The systems load-ability, stability and modularity assure safety with correct planning and safe work methods, which are easily done using the instructions and illustrations within this user information guide.

### **SAFETY WARNINGS**

- The respect of these instructions does not exempt from compliance with all safety regulations in force in the country where you use the system.
- These instructions are intended for users of Fowler products and systems. Operators must be aware of the contents of this manual; in case they have difficulties in reading the same, contact Fowler Formwork Manager.
- The User's Manual instructions must always be available at the workplace for all operators.
- This manual, even if used in order to draw up a Method Statement, will not substitute it, and the Method Statement will remain an important and unavoidable site document, responsibility of the client.

• **Information and illustrations contained herein are relative to only the system in question, and therefore not exhaustive about the overall security; always refer to the applicable health and safety regulations in the area of use of the equipment.**

• **In relation to flow, configuration, installation, use and dismantling of equipment Strictly obey all instructions contained herein; failure to comply with them may result in serious injury to people, as well as extensive property damage.**

• Take every precaution consequently due to the climatic conditions of the site (i.e. in case of rain and/or ice to provide anti-slip measures etc.)

• Periodically verify, especially after severe weather conditions, any connection, wedge or any other connecting element, in order to avoid any possible system instability and consequent accidents.

SYSTEM COMPONENTS

**1. ALUMINIUM PROPS**

- A** Outer Tube
- B** Inner Tube
- C** Safety Hook
- D** Adjusting Nut
- E** Bearing Plate
- F** Foot plate
- G** Head Plate

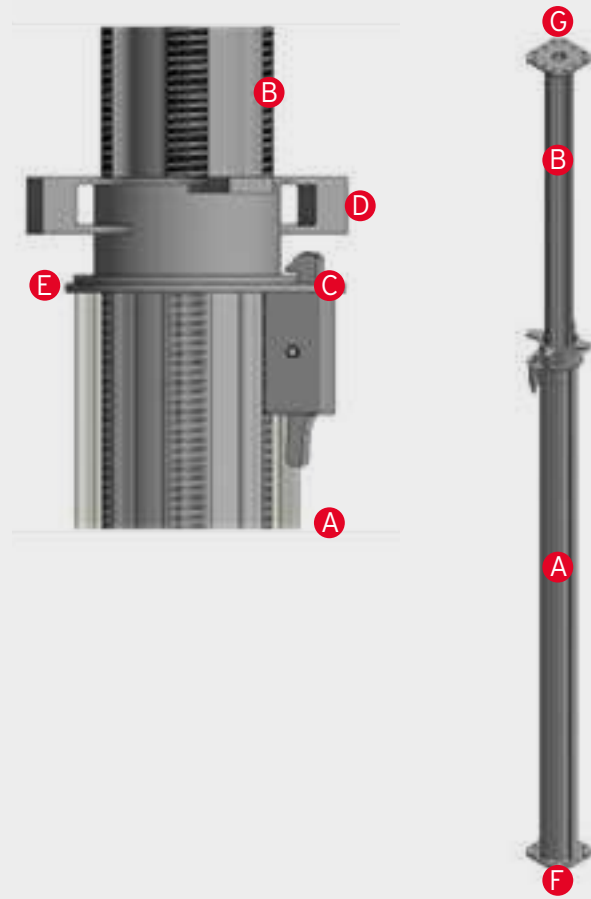

**2. ALU PROP CONNECTING FRAMES**

- A** Wedge Connection
- B** Wedge

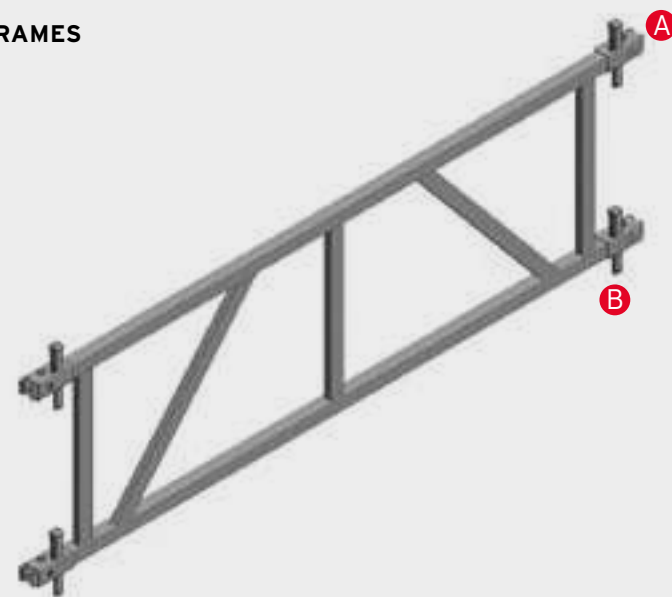

ACCESSORIES

**3. ALU PROP EXTENSIONS**

- A** Outer Tube
- B** End plates



**4. ALU PROP TRIPOD**



**5. ALU PROP WALING CONNECTOR**

- A** Fixing Hook
- B** Connecting plate
- C** Threaded rod M 16
- D** Nut M 16

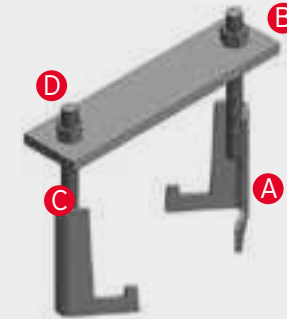

**6. ALU PROP CONNECTING BOLT**

- A** Bolt M 12
- B** Nut M 12

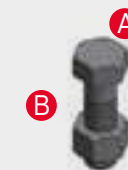

**7. ALU PROP CLAMP & COUPLER**





**ALUMINIUM PROPS TF P 105 / TF P 70**

Aluminium alloys with very high yield strength (R=300N/mm<sup>2</sup>) guarantee high loadability and material lightness.

Interrupted and specular thread obtained by mechanical removal, guarantees self-cleaning and antiscuffing handling of the adjusting nut.

Mechanical assembly of all the components allows minimal maintenance costs and easiness of damaged item replacement.

The special outer tube geometry with resulting "slots" allows the easy attachment of the connecting frames.

Double safety system avoids the exit of the inner prop.

P 105 is the TF Aluminium Prop for slabs, to be used in standard configuration or coupled with Alu Prop Connecting Frames to shift to a tower system when convenient. It guarantees the maximum loadability of TF Alu Prop System.

ART.	H closed mm	H open mm	Weight Kg	Loadability H Max (kN)
PUNT1600105V	1000	1600	13.0	93
PUNT2500105V	1450	2500	17.0	93
PUNT3500105V	1950	3500	21.5	59
PUNT4200105V	2650	4200	23.0	45
PUNT4800105V	2600	4800	27.5	40
PUNT5500105V	3300	5500	30.5	32
PUNT6250105V	4300	6250	35.0	28



ALUMINIUM PROPS TF P 105

TF Alu prop 70 are smaller in diameter and therefore even lighter, when the loads allow it. The main differences between P 105 and P 70 Alu Props, other than different diameters, and obviously the loadability, are focused on the model P 70 L420, where the prop configuration shift from the "standard" outer/internal tube coupling to a "double internal tube", and it derives from the need to maintain an high loadability also for this extraction length.

ART.	H closed mm	H open mm	Weight Kg	Loadability H Max (kN)
PUNT305070V	1750	3050	11,5	20
PUNT420070V	2900	4200	16,5	20



ALUMINIUM PROP TF P 70 - 3050

ALUMINIUM PROP TF P 70 - 4200

**ALU PROP CONNECTING FRAMES**

ART.	Height mm	Lenght mm	Weight Kg
TL500105SZ	500	500	6.5
TL1000105SZ	500	1000	9.3
TL1250105SZ	500	1250	10.5
TL1500105SZ	500	1500	11.5
TL2000105SZ	500	2000	14.0
TL2500105SZ	500	2500	15.7



**EXTENSIONS P 105**

Extension can be used as a Prop extension to make it longer when needed, or as a link between 2 base plates of 2 props ( with 4 bolts M 12 x 40 in diagonal ) to extend the tower working height.

Made with the same aluminium structure and features as the Alu-Props.

ART.	Height mm	Weight Kg
P500105V	500	3.5
P1000105V	1000	5.7
P1500105V	1500	8.0
P2000105V	2000	10.2
P3000105V	3000	14.8

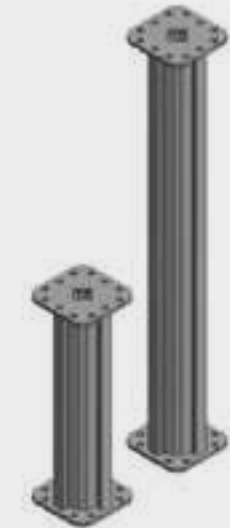

**CONNECTING TF ALU PROPS EXTENSIONS**

**1. ERECTION**

- A** Position the TF Alu Prop on the chosen extension
- B** Insert four Alu Prop Connecting Bolts in dedicated Prop and Extension plate holes (diagonally corresponding so that a "square" will be formed) and securely screw them
- C** Alu Prop and it's extension are now correctly fixed and ready to use

**2. DISMANTLING**

- D** Loosen the connecting bolts
- E** Remove the extension.



fig 1

**ALU PROP CONNECTING FRAMES**

**1. ERECTION**

The connecting frames have to be connected to the props so that the wedge can only be hammered into position from the top, as per images besides show. Alu Prop Tripods are the ideal aid in assembling phase.

- A** Open the clamp claw ensuring the wedge remain at the top Fig 2
- B** Lock the clamp claw in the TF Alu Prop profile. Fig. 3
- C** Keep the clamp claw closed.
- D** Hit the wedge with the hammer until the clamp is firmly locked.
- E** Close the other wedge connections (four clamps for each connecting frame) in the same way.

The frame is now properly mounted to the props Fig. 4

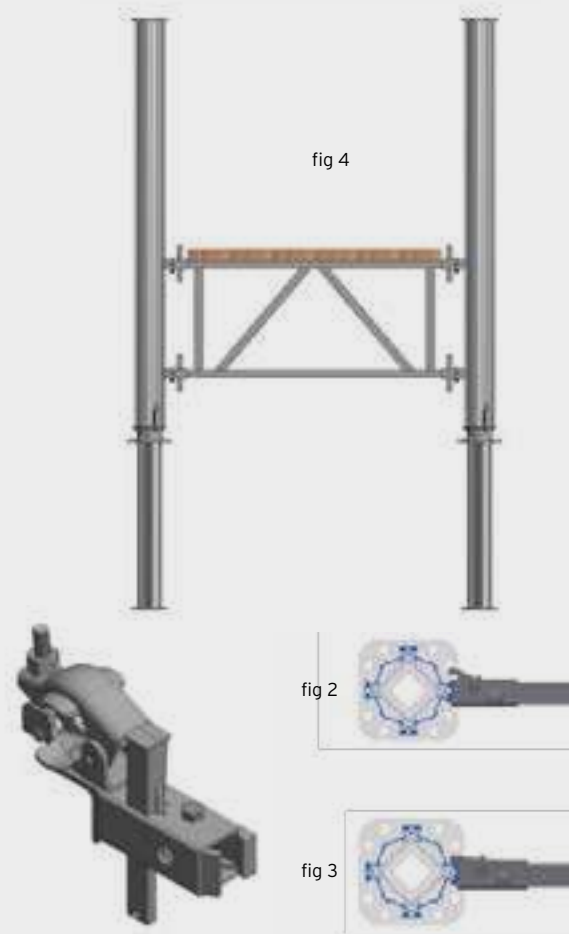

fig 4

fig 2

fig 3

**ALU PROP WALING CONNECTOR**

In presence of high loads, steel walers can be adopted as main beams, and can be fixed to the props instead of H20 wooden beams, i.e. when configuring TF Alu Prop shoring towers as "Table System".

**1. ERECTION**

- A** Loosen the Nut M 16 on threaded rod M 16 (1)
- B** Position the connecting plate on U-profile top wings (2)
- C** Insert the fixing hooks, from below, in the holes of the prop head plate (3)
- D** Tighten the Nut M 16 on threaded rod M 16

**2. DISMANTLING**

- A** Loosen the Nut M 16 on threaded rod M 16 (1)
- B** Pull the fixing hooks out of the prop head plate and remove the connecting plate.

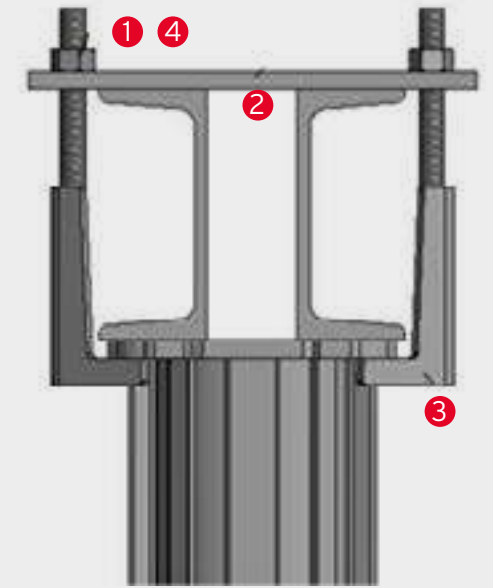

fig 5

**ASSEMBLING INSTRUCTIONS**

**TF ALU PROP PREPARATION**

- A** Press the safety hook (1) and release the adjusting nut (2).
- B** Extract the inner tube (3) to required prop length and adjust nut.
- C** The inner tube must be pushed in until the adjusting nut lies on the bearing plate (4).
- D** Lock the safety hook (1).
- E** Adjust to the exact prop length by screwing the adjusting nut (2).

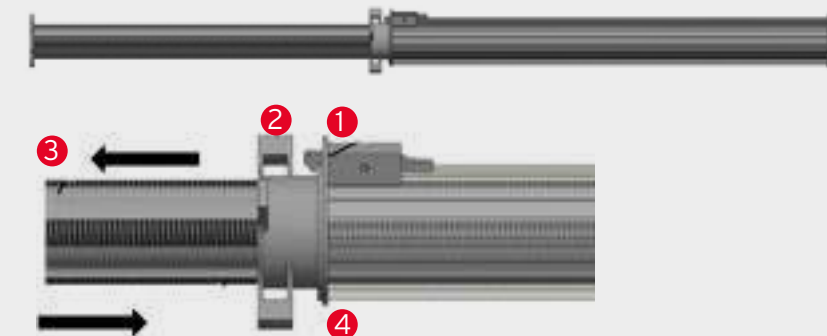

fig 7

**TF ALU PROP CONNECTION**

**TF ALU PROP CONNECTING BOLT**

The Connecting Bolt allows to “couple” two Alu Props through their end plate ( four bolts for each connection) Fig. 8

**1. ERECTION:**

- A** Position the two props on top of each other making sure the flanges match precisely (1)
- B** Insert four Connecting Bolts “diagonally” so that they form a “square” (2)
- C** Screw the Bolts securely.

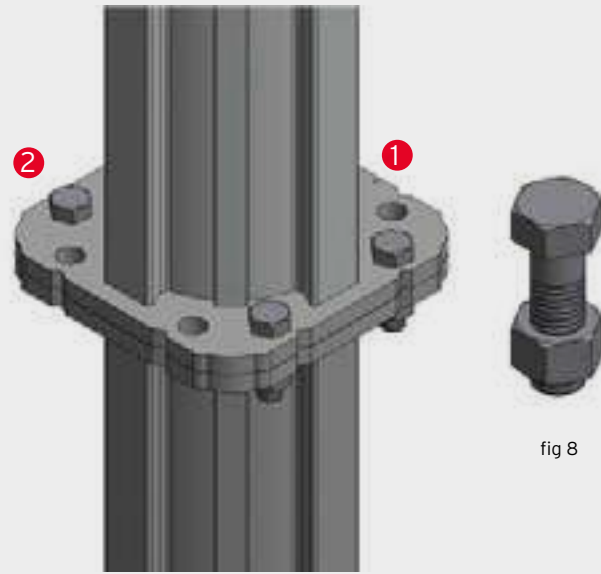

fig 8

The props are now connected and ready to use Fig. 9.

fig 9

**TF ALU TOWERS HORIZONTAL ASSEMBLY**

Because of safety considerations, horizontal assembly is recommended in order to minimize any avoidable risk for workers. An adequately levelled area is necessary to correctly execute the horizontal assembly.

Before lifting Alu Tower into working position, carefully check all connections to props connecting bolts, connecting frames wedge connectors etc... visually and mechanically.

**1. ERECTION:**

- A** Adjust the props length as previously described in “System Details” paragraph.
- B** Lay down both props and connecting frames in planned configuration, refer Fig.10.
- C** Connect the props with each other and the connecting frames (Fig. 11) to the props as per instructions Fig. 12
- D** Fix following connecting frames in vertical direction (1) and, after connecting another “couple” of Alu Props, lay them on top of the connecting frames (2), executing the connections with the same sequence and recommendations described in previous phases Fig. 13.
- E** Complete the tower assembly by connecting the last connecting frames as per previous instructions Fig.14. and install locking clamp to underside of connecting frames.
- F** The Alu Tower is now ready to use and can be lifted by crane ropes or chains to the foreseen operative position Fig. 15.

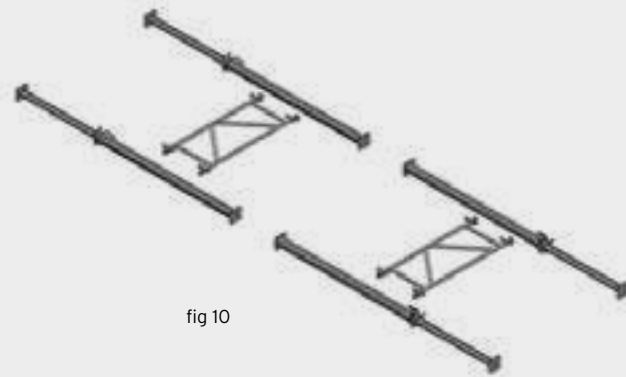

fig 10

- G** Once the Alu Tower is in position the working deck and perimeter hand railing can be installed using elevated work platform or other safe measures.

**TF ALU TOWERS HORIZONTAL ASSEMBLY**

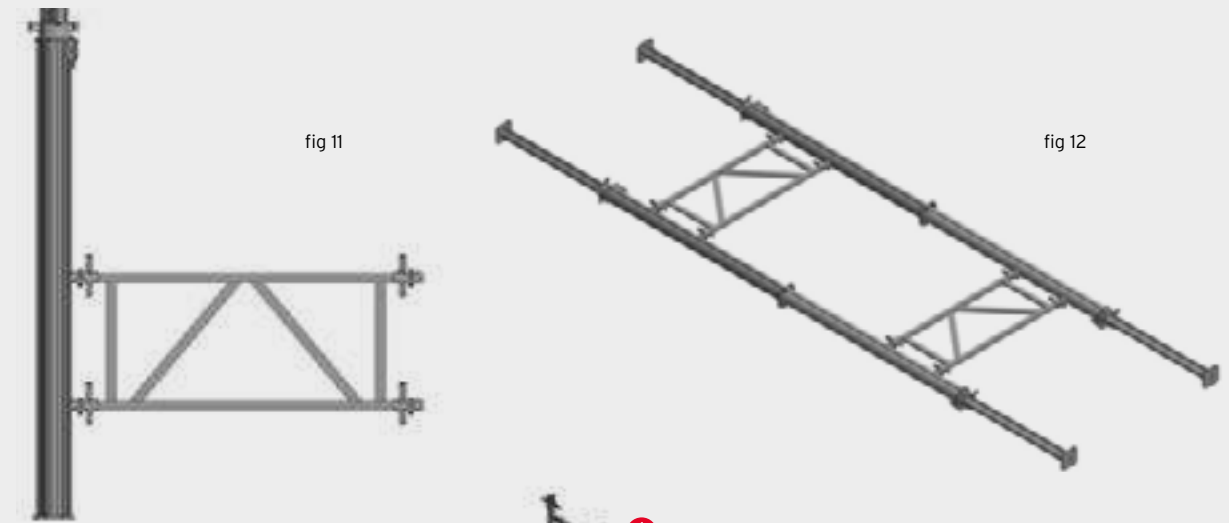

fig 11

fig 12

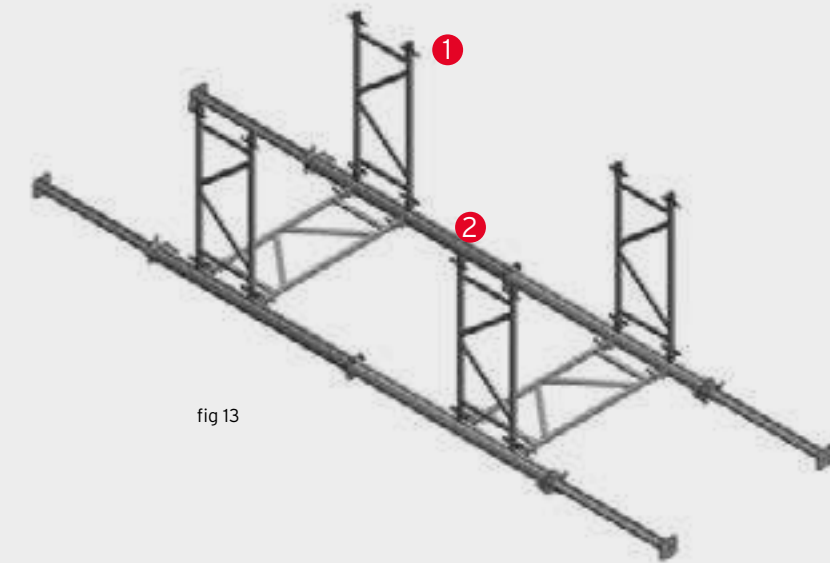

fig 13

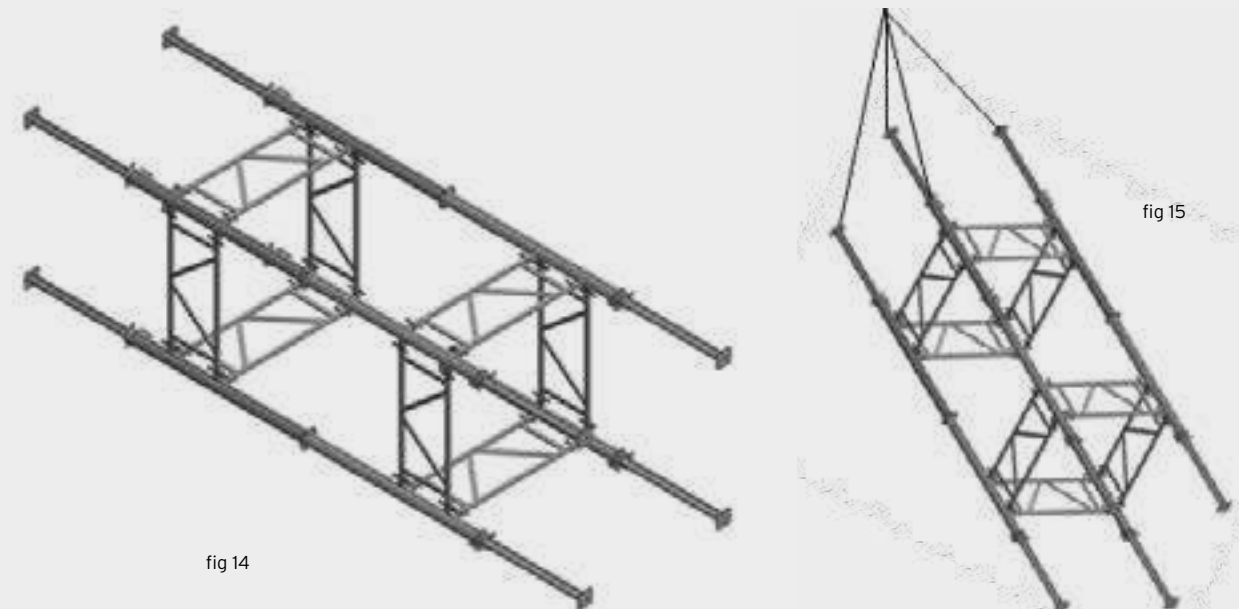

fig 14

fig 15



**TF ALU TOWERS VERTICAL ASSEMBLY**

If site conditions or other stringent reasons make it impossible to operate horizontally, then a vertical assembly procedure must be considered and applied, taking in account every possible safety measure to avoid risks.

**1. ERECTION:**

- A** Adjust the props length as previously described in "System Details" paragraph.
- B** Put the props in vertical position by the aid of TF Alu Prop Tripod Fig. 16
- C** Install the necessary connecting frames as per previous instructions Fig. 17 and install locking clamps to underside of the connecting frames.
- D** Install timber scaffold boards to top of connecting frames to form working deck / catch deck, ensuring the boards are fixed into each other and into place. Any large gaps should be covered with lap boards or plates. (This may require a mobile access platform to complete this task)
- E** Connecting frames should be installed as perimeter edge protection, if there is no other form of edge protection in place. Carefully check all props, connection bolts, connection frames and locking clamps prior to accessing working deck / catch deck.  
This process is followed for and any additional decks required, till tower is complete. Appropriate access systems must be used for safe access and egress of decks

**2. DISMANTLING**

Dismantle of the towers is done in the reverse method of erection, using appropriate mobile access platforms.



fig 16



fig 17

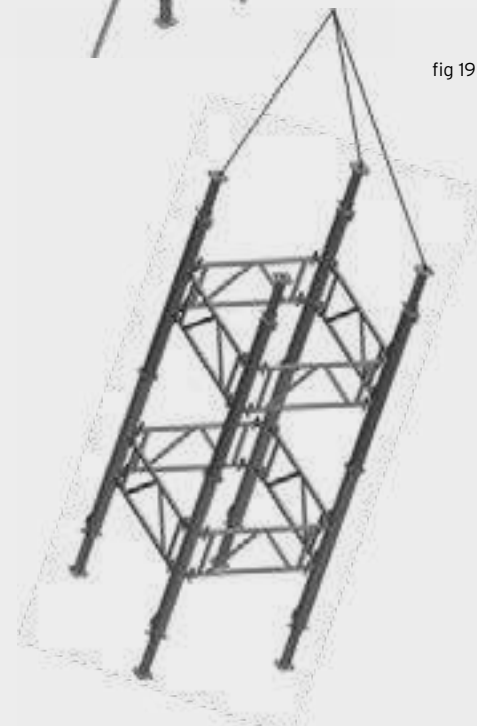
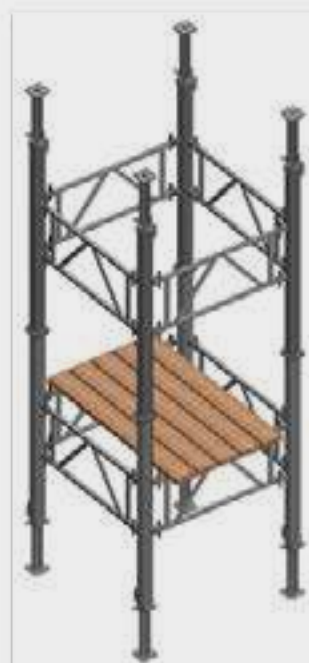

fig 19



fig 18



**TF ALU TOWERS TUBE & COUPLER BRACING**

On site it's not unusual to have the necessity to provide specific bracings not easy to foresee beforehand; other than above mentioned situations and specific needs, the "Tube & Coupler" bracing system could be a helpful aid also during the assembling phase. In any case, the Alu Prop "Clamp & Coupler" Fig. 22, is the ideal item to combine the TF Alu Prop with standard tubes to be used as bracings Fig. 20 - 21.



fig 20



fig 22

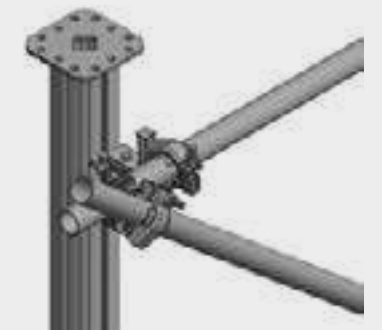

fig 21

**TRANSPORT & STORAGE**



Frames (20/pcs)



Props (49/pcs)

**ALUMINIUM PROPS P 105**



CODE	DESCRIPTION	WEIGHT (KG)
PUNT1600105V	Alu Prop 105 1000/1600 mm	13.0
PUNT2500105V	Alu Prop 105 1450/2500 mm	17.0
PUNT3500105V	Alu Prop 105 1950/3500 mm	21.5
PUNT4200105V	Alu Prop 105 2650/4200 mm	23.0
PUNT4800105V	Alu Prop 105 2650/4800 mm	27.5
PUNT5500105V	Alu Prop 105 3300/5500 mm	30.5
PUNT6250105V	Alu Prop 105 4300/6250 mm	35.0

**ALUMINIUM PROPS P 70**



CODE	DESCRIPTION	WEIGHT (KG)
PUNT305070V	Alu Prop 70 1750/3050 mm	11.5
PUNT420070V	Alu Prop 70 2900/4200 mm	16.5

**ALU PROP CONNECTING FRAMES**



CODE	DESCRIPTION	WEIGHT (KG)
TL500105SZ	Steel frame 500 mm galvanized	6.5
TL1000105SZ	Steel frame 1000 mm galvanized	9.3
TL1250105SZ	Steel frame 1250 mm galvanized	10.5
TL1500105SZ	Steel frame 1500 mm galvanized	11.5
TL2000105SZ	Steel frame 2000 mm galvanized	14.0
TL2500105SZ	Steel frame 2500 mm galvanized	15.7

**ALU PROP EXTENSIONS**



CODE	DESCRIPTION	WEIGHT (KG)
P500105V	Prop extension L500 mm	3.5
P1000105V	Prop extension L1000 mm	5.7
P1500105V	Prop extension L1500 mm	8.0
P2000105V	Prop extension L2000 mm	10.2
P3000105V	Prop extension L3000 mm	14.8

**ALU PROP WALING CONNECTOR**



CODE	DESCRIPTION	WEIGHT (KG)
TF5821220A	Alu Prop Waling connector	1.5

**ALU PROP CONNECTING BOLT**



CODE	DESCRIPTION	WEIGHT (KG)
Bolt M12	Alu prop Connecting Bolt	0.2

**ALU PROP TRIPOD**



CODE	DESCRIPTION	WEIGHT (KG)
TPR116	Alu Prop Tripod	11.00

**ALU PROP CLAMP & COUPLER**



CODE	DESCRIPTION	WEIGHT (KG)
TF5825610A	Alu Prop Clamp & Coupler	4



**FOWLER**

**SCAFFOLD HOISTS FORMWORK**

EURO PROPS

EN 1065

USER INFORMATION



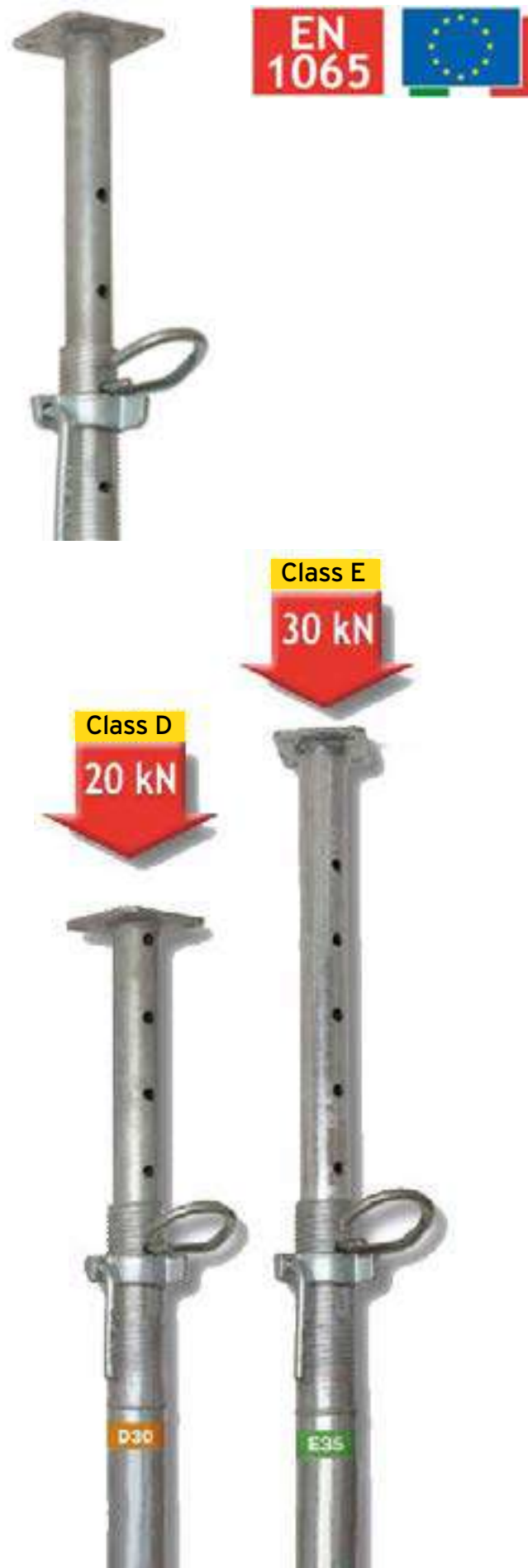

**EN 1065**



TABLE OF CAPACITY LOAD

**STEEL PROPS EN1065 CLASS "D"**

ART.	TFH20D30 STEEL PROP D30		TFH20D35 STEEL PROP D35		TFH20D40 STEEL PROP D40		TFH20D55 STEEL PROP D55	
	EXTENSION (mm)	CAPACITY LOAD UP (kN)	CAPACITY LOAD DOWN (kN)	CAPACITY LOAD UP (kN)	CAPACITY LOAD DOWN (kN)	CAPACITY LOAD UP (kN)	CAPACITY LOAD DOWN (kN)	CAPACITY LOAD UP (kN)
5.500							21.8	30.2
5.400							22.9	33.3
5.300							23.9	36.5
5.200							25.1	
5.100							26.6	
5.000							27.5	
4.900							29.3	
4.800							30.6	
4.700							32.6	
4.600							33.7	
4.500							35.6	
4.400								
4.300								
4.200								
4.100								
4.000						21.8	31.2	
3.900						22.6	37.2	
3.800						24.5		
3.700						26.5	37.6	
3.600						27.7		
3.500			23.9	35.5	29.6			
3.400			26.0		31.9			
3.300			28.1		33.8			
3.200			30.3		35.2			
3.100			32.1		36.4			
3.000	29.3	34.8	33.3			37.6		
2.900	30.7		34.2					
2.800	31.6		34.8					
2.700	32.2		35.4	37.6				
2.600	32.9		36.9		37.6			
2.500	33.6							
2.400	34.6							
2.300	35.7	37.6						
2.200	37.2		37.6					
2.100								
2.000	37.6							
1.900								
1.800								

TABLE OF CAPACITY LOAD

**STEEL PROPS EN1065 CLASS "E"**

ART.	TFH20E30 STEEL PROP E30		TFH20E35 STEEL PROP E35		TFH20E40 STEEL PROP E40		TFH20E45 STEEL PROP E45		
	EXTENSION (mm)	CAPACITY LOAD UP (kN)	CAPACITY LOAD DOWN (kN)	CAPACITY LOAD UP (kN)	CAPACITY LOAD DOWN (kN)	CAPACITY LOAD UP (kN)	CAPACITY LOAD DOWN (kN)	CAPACITY LOAD UP (kN)	CAPACITY LOAD DOWN (kN)
4.500								30.9	32.5
4.400								32.8	34.8
4.300								34.8	37.0
4.200								37.0	
4.100									
4.000							33.2		
3.900							36.8		
3.800							39.0		
3.700							41.2		
3.600							42.5		
3.500				32.0	34.1				
3.400				35.3	38.5				
3.300				37.7	41.8				
3.200				40.6	42.1				
3.100									
3.000	32.4								
2.900	35.8								
2.800	36.4								
2.700	37.7								
2.600	38.8								
2.500	39.7								
2.400	40.7								
2.300	42.1								
2.200									
2.100									
2.000	42.8								
1.900									
1.800									

TABLE OF CAPACITY LOAD

**STEEL PROPS EN1065 CLASS "D ECO"**

ART.	TFH20D30ECO STEEL PROP D30 ECO		TFH20D35ECO STEEL PROP D35 ECO		
	EXTENSION (mm)	CAPACITY LOAD UP (kN)	CAPACITY LOAD DOWN (kN)	CAPACITY LOAD UP (kN)	CAPACITY LOAD DOWN (kN)
3.500				15.9	24.9
3.400				17.0	
3.300				18.1	
3.200				19.3	
3.100				20.2	
3.000	23.5	31.4	20.8		
2.900	24.2	33.8	21.0		
2.800	24.6	36.4	21.1		
2.700	25.0		21.4		
2.600	25.2		22.0		
2.500	25.5		23.3		
2.400	25.8		25.1		
2.300	26.3	37.6	28.8	28.8	
2.200	27.3				
2.100	29.5		30.9	30.9	
2.000	32.7				
1.900					
1.800	37.6				

ITEMS LIST

**STEEL PROPS EN1065**

CODE	DESCRIPTION	WEIGHT (KG)
TFH20D30	Steel Prop D30 Hot-dip galvanized 3000/1800 mm	17.8
TFH20D35	Steel Prop D35 Hot-dip galvanized 3500/2000 mm	19.7
TFH20D40	Steel Prop D40 Hot-dip galvanized 4000/2200 mm	22.1
TFH20D55	Steel Prop D55 Hot-dip galvanized 5500/3000 mm	35.0
TFH20E30	Steel Prop E30 Hot-dip galvanized 3000/1800 mm	18.3
TFH20E35	Steel Prop E35 Hot-dip galvanized 3500/2000 mm	23.8
TFH20E40	Steel Prop E40 Hot-dip galvanized 4000/2200 mm	26.9
TFH20E45	Steel Prop E45 Hot-dip galvanized 4500/2500 mm	28.5
TFH20D30ECO	Steel Prop D30 ECO Hot-dip galvanized 3000/1800 mm	15.9
TFH20D35ECO	Steel Prop D35 ECO Hot-dip galvanized 3500/2100 mm	17.6





# **FOWLER**

**SCAFFOLD HOISTS FORMWORK**

**Hoists • Scaffolding • Formwork • Hire • Sales  
Design & Fabrication**

T. +61 2 9426 9700  
info@fowlerhire.com.au | www.fowlerhire.com.au

1333 Horsely Dr • PO Box 6481  
WETHERILL PARK NSW 2164 • ABN 11 475 492 079

ScafworX Investments Pty Ltd atf ScafworX  
Unit Trust t/a Fowler Sales and Hire



ISO 9001  
BUREAU VERITAS  
Certification

